



# GMOD TEST STAND MANUAL (TSM)

12-21-2015

## ***Table of Contents***

1.	Mounting the Engine on the Test Stand	p. 2
2.	Dynamometer	p. 2
3.	Engine to Dyno Driveline	p. 2
4.	External Engine Oil Circuit	p. 2
5.	Induction System	P. 3
6.	Exhaust System	P. 4
7.	Fuel System	p. 5
8.	Engine Cooling System	p. 5
9.	Crankcase Ventilation System	p. 5
10.	Additional Requirements	
	10.01 Cylinder Surface Finish Analyzer Fixture	p.9
	10.02 Test Cell Ambient Thermocouple	p. 9
11	Appendix	
	11.01 Appendix A, Flywheel Adapter Plate	p.10
	11.02 Appendix B,	
	11.02.1 External Oil System setup and Flow Direction,	P. 12
	11.02.2 Camaro Oil Cooler Plate Sheets 1, 2 and 3	p. 13-15
	11.03 Appendix C, Airbox thermocouple/pressure transducer	P. 16-24
	11.04 Appendix D, Throttle Body Lever Arm,	p. 25
	11.05 Appendix E, GMOD Exhaust Down-Pipe Taps,	p. 26
	11.06 Appendix F Surface Finish Analyzer Support Drawings,	p.26-39
	11.07 Appendix G Crankcase Ventilation System,	p. 40-41
	11.08 Appendix H, Bore Measurement Ladder	p.42

1. **Mounting the Engine on the Test Stand**---Mount the engine on the test stand according to the following:
  - 1.01 Use OHTGMOD-006-1 front and OHTGMOD-007-1 rear engine mounts.
  - 1.02 Use Mercury Quicksilver 66284A engine mounts.
  - 1.03 Level the engine so it is at 0.0 degrees side-to-side and 90 degrees on the flywheel face. Connect the driveline between the engine and dyno.
  
- 2.0 **Dynamometer**--- A Midwest 1014 dynamometer is to be used.
  - 2.01 The engine shall start using an air starter mounted on the rear of the dynamometer capable of cranking the engine at 300 +/- 50 rpm with spark plugs removed.
  - 2.02 **Dynamometer Load Cell Temperature Control.** Control the load cell temperature. Enclose the dynamometer load cell to protect it from the variability of laboratory ambient temperatures. Maintain air in the enclosure within the operating temperature range specified by the load cell manufacturer within a variability of no more than 6 °C. Control temperature by a means that does not cause uneven temperatures on the body of the load cell.
  
- 3.0 **Engine to Dyno Driveline**---Connect the engine to the dyno in the following manner:
  - 3.01 The driveline must meet the MSI-41RE-xx specification.

MSI = Machine Service, Inc

41RE = 1410 series Dana shaft w/rubber isolation

“xx” =driveshaft length
  - 3.02 To connect the driveline to the engine flywheel use adapter plate in Appendix A.
  
- 4.0 **External Engine Oil Circuit**---This oil circuit includes a filter and a heat exchanger.
  - 4.01 Use the Canton Remote Filter Adapter part # CTR-22-598 and O-ring Kit CTR-98-004.
  - 4.02 Use OHT6A-012-4 Oberg oil filter housing with OHT6A-013-3, 60 micron filter.
  - 4.03 Use the Camaro oil cooler, 12607900 as supplied by Chevrolet Performance Warehouse (CPW). This cooler is to be mounted vertically to

aid in bleeding air from the system as shown in Figure 1.



Figure 1

- 4.04** Refer to the drawing “Camaro Oil Cooler plate” sheet 1, 2, and 3 in Appendix B2 to mount the cooler. McMaster Carr 4464K473 Type 304 Stainless Steel Half Coupling is used with this plate to connect the oil/coolant hoses.
- 4.05** External oil circuit configuration. See Appendix B1. The oil will exit the engine through the Canton remote oil filter adapter to the Camaro oil cooler to the Oberg filter then back to the Canton adapter and into the engine block.
- 4.06** External oil circuit hose and fitting specifications. Number 10 A/N fittings and braided lines are to be used. No 90 degree fittings are to be used, only straight or 45 degree to reduce the pressure drop. The total line length is to be 50 in. +/- 2 in. The capacity of this oil circuit must be kept to a minimum so as much oil remains in the engine at all times.

## **5.0 Induction System.**

- 5.01** Use these air intake GM part numbers. Air box 92230374, air filter 92196275, and air duct 92196314.
  - 5.01.1** The air filter is to be replaced a minimum of once per reference period (15 candidate tests or 120 days).
  - 5.01.2** There must be no bends in the bellows of the air duct where it attaches to the air filter housing. The intake air needs to remain straight as it exits the MAF sensor and travels through the bellows. Any bends will cause inaccurate readings by the MAF sensor.
- 5.02** Airbox thermocouple and pressure transducer location are in Appendix C.
- 5.03** Use two throttle bodies both are part number 12629992 available from GM Dealerships. One with the modified throttle linkage is mounted on the engines intake manifold. A second throttle body is connected to the wiring harness and mounted at the stand.



Figure 2



Figure 3

**5.04 Intake Manifold Vacuum.** Use a transducer having a range of 0 to 100 kPa. Connect the transducer to port indicated in figures 2 and 3.

**5.05 Engine throttle body lever arm.** See Appendix D.

**5.06** The production MAP sensor is not connected to the wiring harness. This sensor can be removed and the hole permanently plugged to prevent vacuum leaks. Refer Figure 2 for MAP sensor location.

## 6.0 Exhaust System.

**6.01** Use exhaust manifolds and take down tubes, OHTGMOD-017-1.

**6.02** The process water enters the exhaust manifold through the bottom and exits the top in a counter-flow orientation.

**6.03** Exhaust back pressure valves are required to maintain 3 kPa. See Appendix E.

**6.04** O<sub>2</sub>/NO<sub>x</sub> sensors are located on the take down tubes. See Appendix E.

**6.05** ECM NOx 5210t sensor is to be used in the down tube of each bank. See Appendix E. Information can be obtained from ECM, [sales@ecm-co.com](mailto:sales@ecm-co.com)

## **7.0 Fuel System**

- 7.01** The fuel pressure at the fuel rail is to be controlled to 410 kPa and 35 C +/- 2 C.
- 7.02** Install the fuel thermocouple and the fuel pressure sensor on the inlet side of the fuel rail as shown in the picture below section 5.03 of this document.
- 7.03** Flow test the fuel injectors before each test according to the procedure in the GMOD Engine Build Manual, Section 5 sheet 12.
- 7.04** Fuel rail inlet tube caution note. On the inlet tube to the fuel rail is a crimp which is used in production vehicles to securely attach the fuel feed hose to

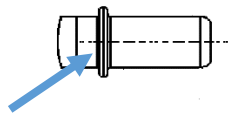

the fuel rail. A crack has been known to form around this crimp causing fuel to leak in engine dynamometer applications. The best practice for attachment of the fuel line to the fuel rail therefore is behind the crimp after the inlet tube on the fuel rail is shortened. See picture in 5.03.

## **8.0 Engine Cooling System**

- 8.01** Use the coolant manifold OHTGMOD-008-1
- 8.02** The coolant flow rate is to be controlled by a variable-frequency drive (VFD) pump with no control valves downstream of the engine.
- 8.03** Use 100% ShellZone® Extended Life DEX-COOL®.
- 8.04** The coolant reservoir tank is to be controlled to a pressure of 123 kPa.
- 8.05** A resistance value of 115.2 ohms is used for the coolant temperature sensor electrical circuit when the test is at operating conditions. This circuit is bypassed for engine starts when the coolant sensor is referenced by the ECM. With the 115.2 ohm circuit the ECM will display a 115C coolant temperature on the OBDII data stream when recorded at the test stand.

## **9.0 Crankcase Ventilation System**

- 9.01** Camaro oil separators, part number 12653073, are to be installed on the oil fill tubes, part number 12584043, in both rocker covers, part number 12582224. When installed correctly the top surface of the separator is horizontal.
- 9.02** Use 0.625" inside diameter tygon hose from the Camaro oil separators to 5/8" barbed adapters and 1/2" pipe Tee fitting above engine. See pictures in Appendix G. page 39 – 40.
- 9.03** The 1/2" pipe Tee fitting and barbed adapters are to be positioned 6" +/- 3" above the engine.
- 9.04** Either the sharp edged orifice or the J-TEC can be used to measure blowby. When the J-TEC is used blow-by gases only flow through the

meter when the measurement is taken. At other times these gases are vented to atmosphere prior to the J-TEC meter.

### **9.05 GMOD Engine J-TEC Model VF563AA Setup and Maintenance Procedure**

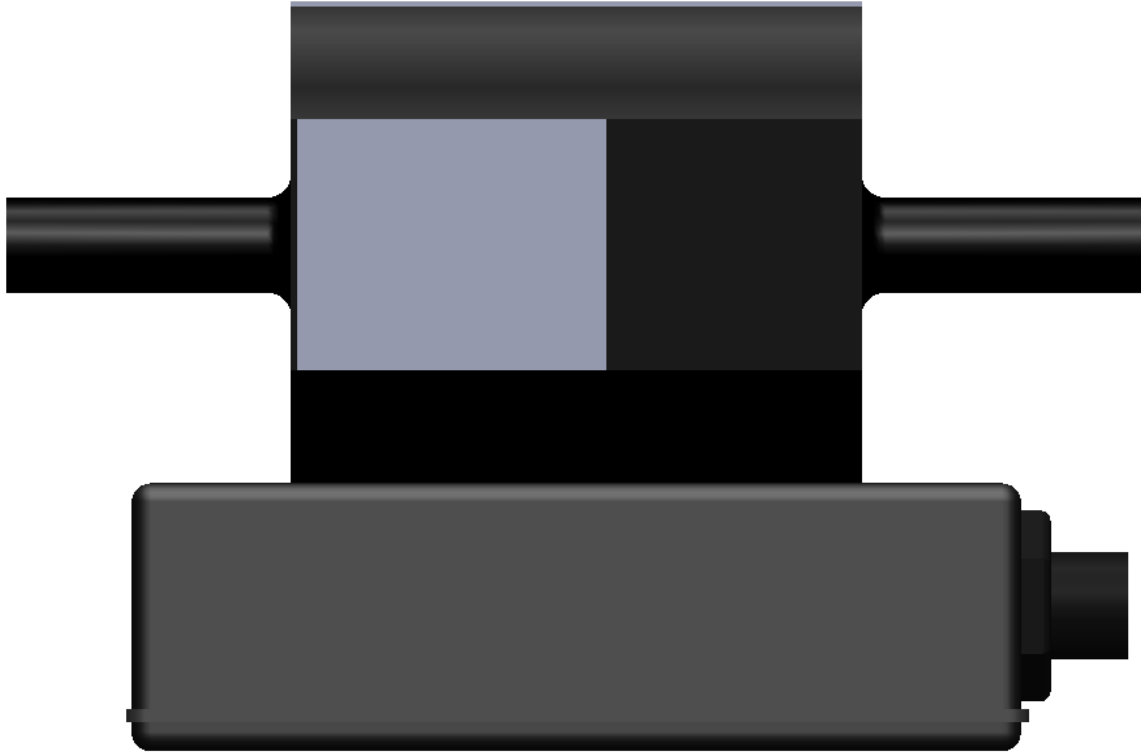

#### **INSTALLATION INSTRUCTIONS**

- 1) The flow meter must be installed with a minimum of 20 pipe diameters of straight pipe upstream and 10 pipe diameters downstream from the flow meter. For example, a one-inch tube or hose must have 20 inches of straight length immediately before the flow meter inlet tube. This condition provides a more symmetrical flow profile, which is necessary to obtain accurate and repeatable results.
- 2) A typical connection to the flow meter is made by placing flexible hose onto the outside of the inlet tube and outlet tube.
- 3) Install the flow meter vertical with flow into the top and out the bottom to encourage liquids to drain out of the flow meter.
- 4) Installing a VF563 CCV6000 filter canister (or buffer chamber) in the pipe between the crankcase and the flow meter minimizes the effect of pulsating flows, and collect oil and water droplets to keep the flow meter cleaner.

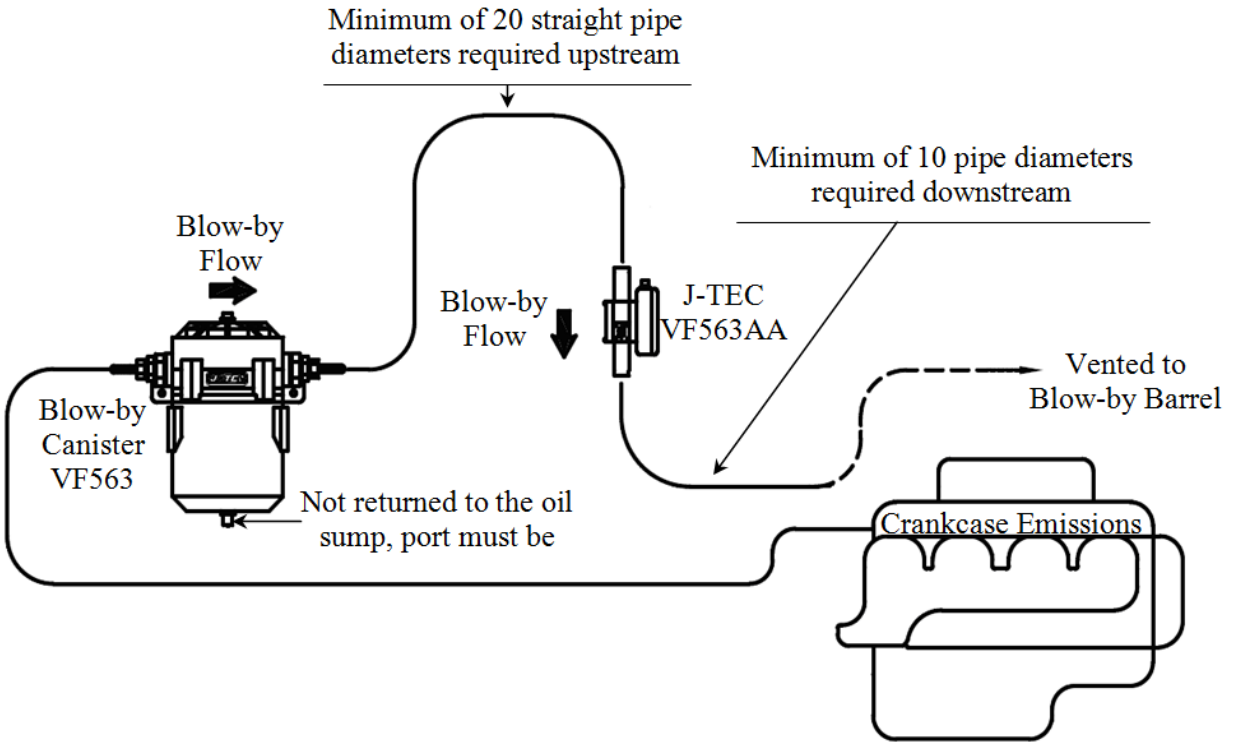

FIGURE B  
Engine Blow-By Measurement System

## CLEANING AND MAINTENANCE

The inside of the flow tube and strut must be kept clean. This cleaning procedure is to be completed prior to every test start.

- 1) To clean the flow tube and strut, gently brush the inside of the tube with a soft brush or cotton swab. A solvent cleaner, such as a brake parts cleaner that degreases and leaves no residue, may be used to loosen deposits. Ensure the solvent is compatible with aluminum, viton, and Teflon.
- 2) DO NOT use wire brushes or use high-pressure liquids. These may cause damage to the transducers.

## ELECTRICAL INSTALLATION

- 1) A filtered power supply must provide at least 35 mA at +12 to +24 Volts Direct Current (VDC).
- 2) Analog output signal is 0 to 5 volts DC, proportional to the flow range. (Output impedance is 100 ohms).
- 3) Four-conductor cable made of 26-22 AWG wire is required to make connections to the flow meter.



- 4) The contact pins, of the flow meter connector, are identified in Figure A. The mating connector, that connects to the flow meter head, is CONXALL part number 6282-5SG-3XX (J-TEC part number DRJ0720).

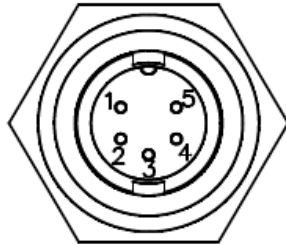

NOTE: Connector viewed from outside of flowmeter

Pin	Color	Description
5		Not Used
4	RED	Power Input (+12 to +24 VDC)
3	WHT	Output (0-5 VDC or Frequency)
2	BLK	Signal Ground
1	BLK	Power Ground

FIGURE A  
Flowmeter Connector Pin-Outs

Recommended Electrical Connections  
(separate grounds for lowest measurement error)

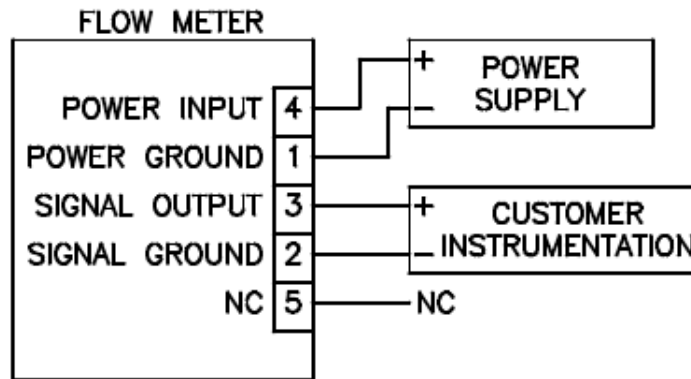

CIRCUIT BOARD OUTPUT JUMPERS

DAA0XXX-0003	ANALOG (0-5V)	P3-2 to P3-3
DAA0XXX-0002	FREQUENCY	P3-2 to P3-1

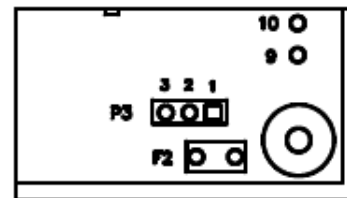

### Citation

J-TEC Associates, Inc. MAN0062 Revision D (S/N 10000 & up). *Operator's Manual for the VF563 Series Flowmeter Installation*. (2013). PDF File.

## **10.0 Additional Requirements**

**10.01 Cylinder Surface Finish Analyzer Fixture.** This fixture must be designed to the GMOD drawings in Appendix F.

**10.02 Test Cell Ambient Thermocouple.** A thermocouple is to be positioned 12" +/- 3" directly above the engine intake manifold to measure test cell temperature.

**10.03 Thermocouple Locations.** Install the sensing tip of all thermocouples in the center of the stream of the medium involved unless otherwise specified.

**10.04 Engine Knock Sensors.** The knock sensors are not to be bolted to the engine block. The wiring connector is to be plugged in to the sensor and tied back to the wiring harness away from the engine.

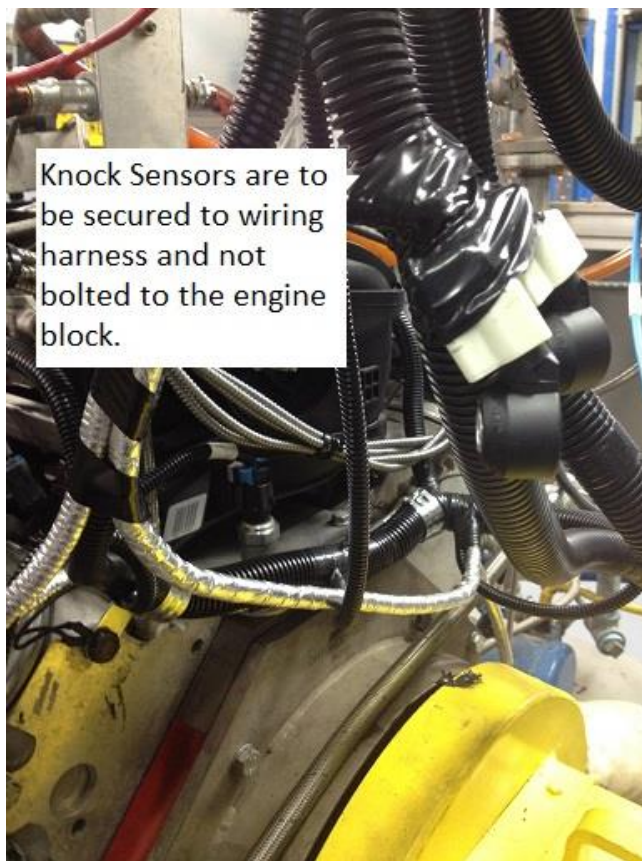

## **Appendix**

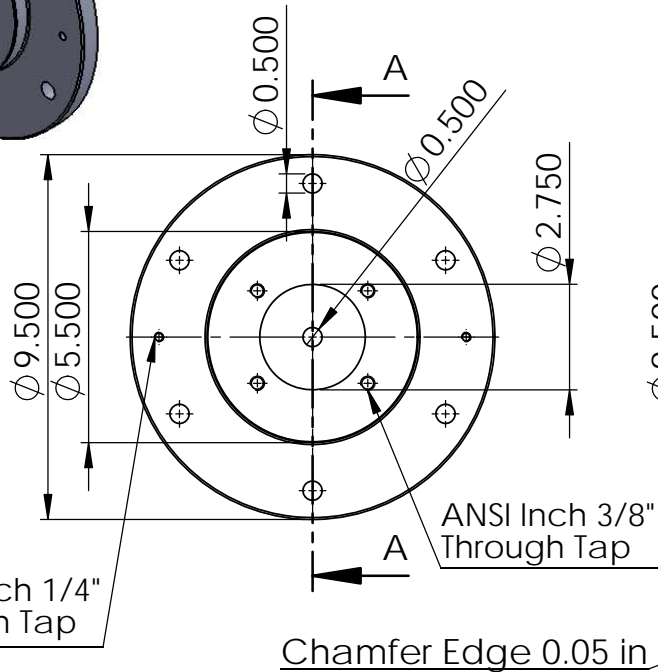
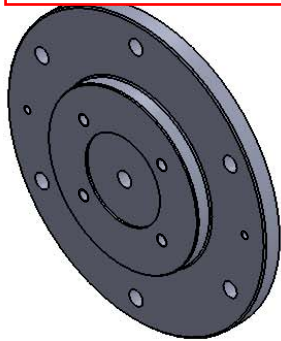

ANSI Inch 1/4" Through Tap

Chamfer Edge 0.05 in

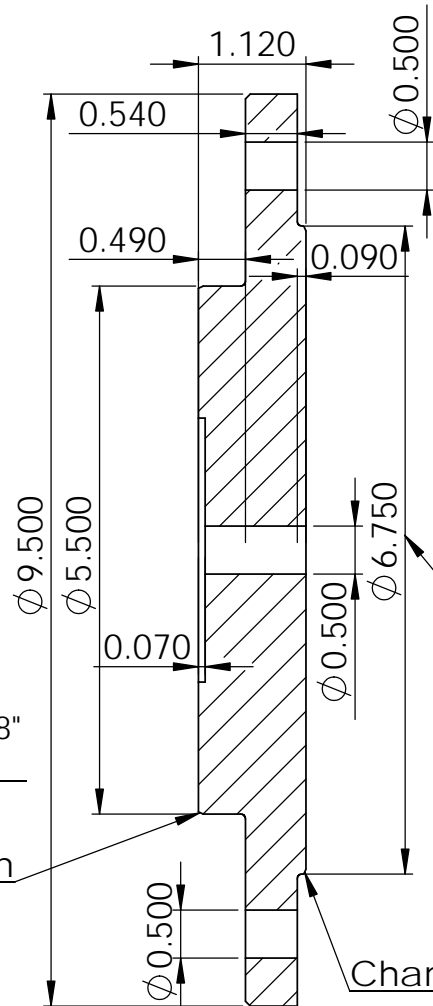

SECTION A-A  
SCALE 1 : 2

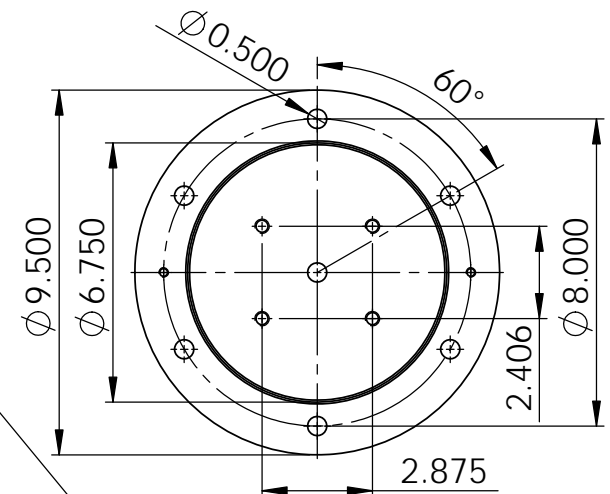

NOTE: Confirm this diameter as it is driven by flywheel dimension specification (172.5 +/-0.2 mm)

Balance Instructions:  
Balance GMOD Flywheel Adapter and Flywheel Assembly with Grade 8 bolts statically or dynamically within 18 g\*cm.

Note: The 6 Through Holes on the GMOD Flywheel Adapter will need to be marked and modified to match the flywheel provided. The flywheel will need 6 ANSI Inch 1/2" Through Taps corresponding to the flywheel adapter dimensions provided in this Drawing.

SOLIDWORKS Drawing Provided by Intertek Automotive Research

		UNLESS OTHERWISE SPECIFIED:	NAME	DATE		
		DIMENSIONS ARE IN INCHES TOLERANCES: THREE PLACE DECIMAL ± 0.005 in	DRAWN		TITLE: <b>GMOD Flywheel Adapter</b>	
		INTERPRET GEOMETRIC TOLERANCING PER:	CHECKED		SIZE <b>A</b> DWG. NO. REV	
		MATERIAL <b>A-36 Steel Plate</b>	ENG APPR.		SCALE: 1:5 WEIGHT: SHEET 1 OF 1	
NEXT ASSY	USED ON	FINISH	MFG APPR.			
APPLICATION		DO NOT SCALE DRAWING	Q.A.			
			COMMENTS:			

### GMOD External Oil System Setup and Flow Direction Camaro Oil Cooler Heat Exchanger

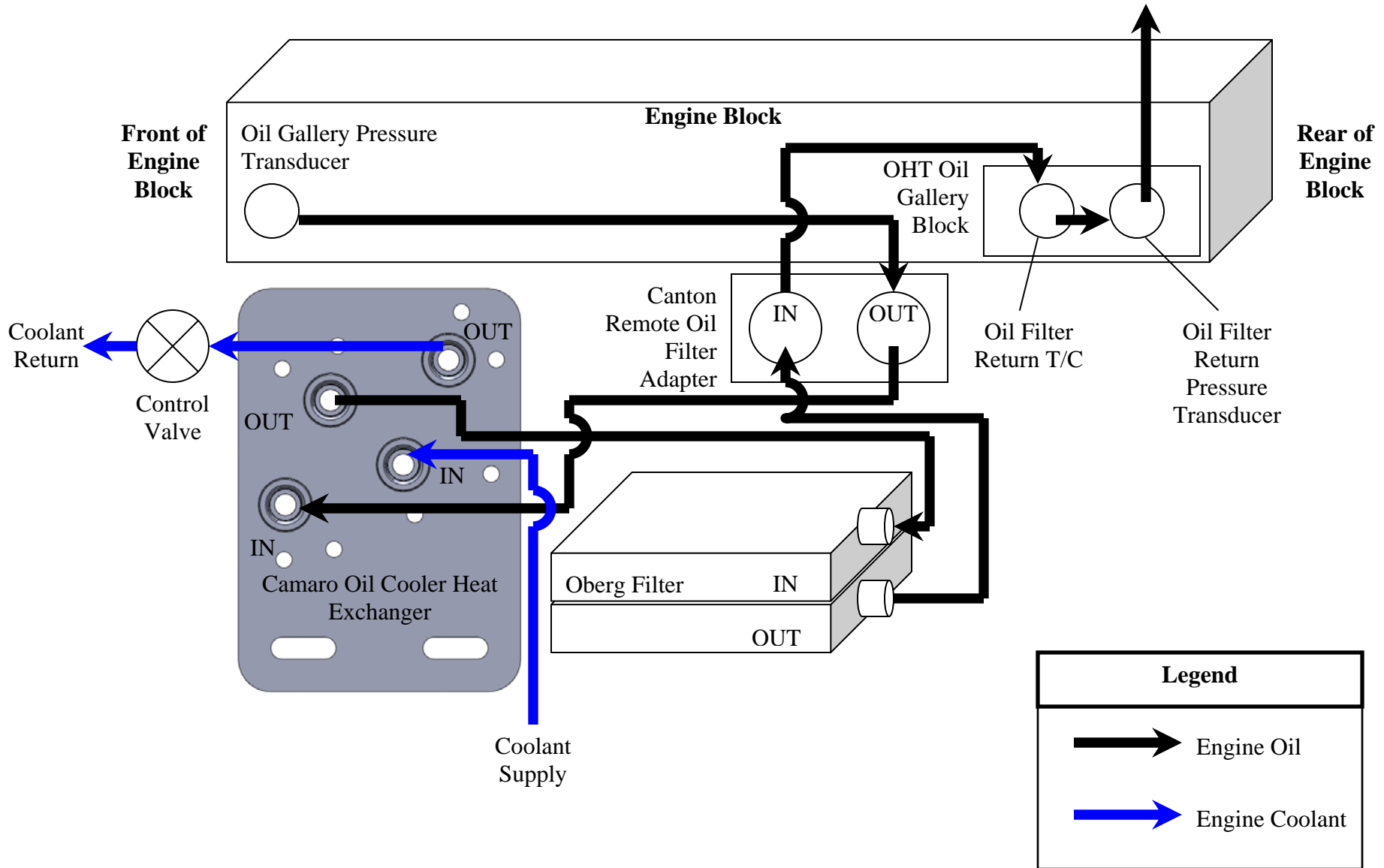

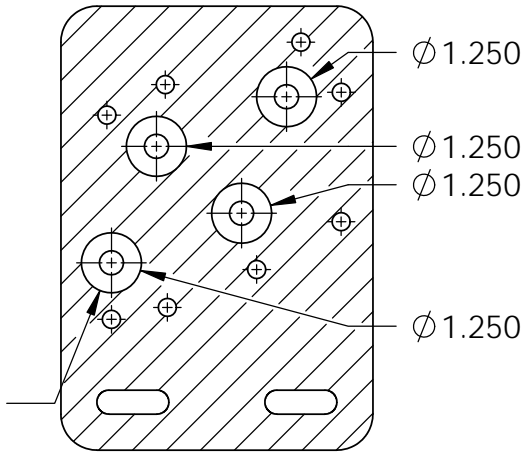
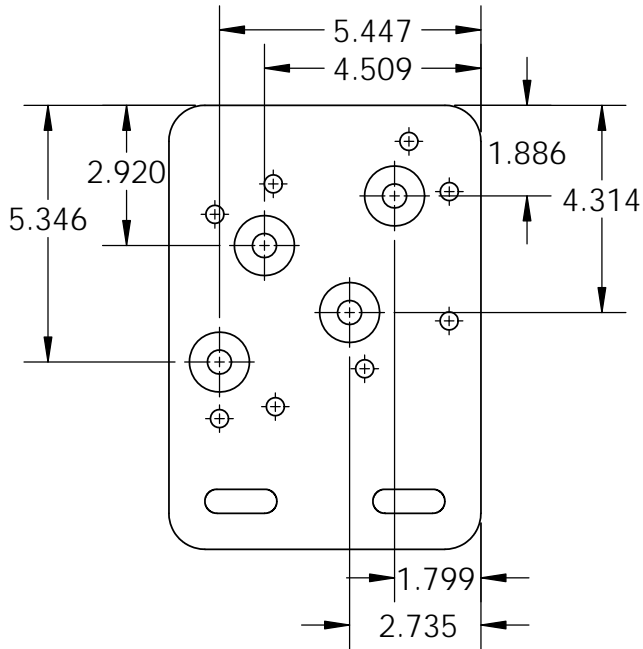
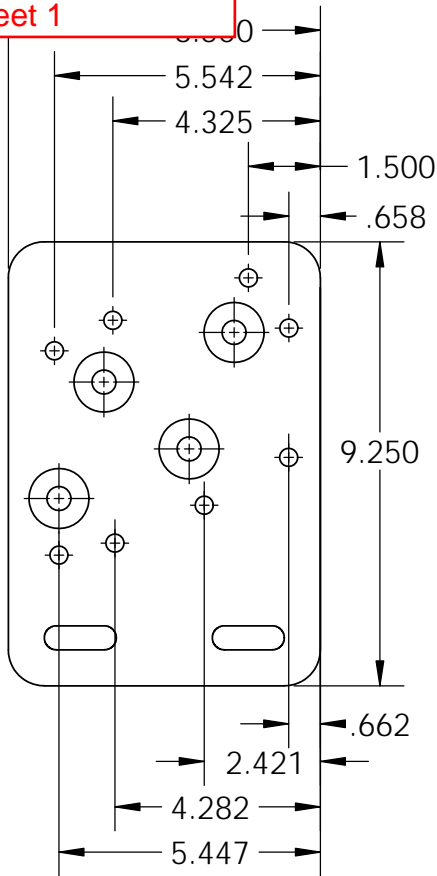

1.250 inch Diameter  
Mill 0.250 inches  
into Plate (x4)

Type 304 Stainless Steel  
Half Coupling (x4): 1/2  
NPT Pipe Size, 14 Threads  
Per Inch, 0.53" Thread  
Engagement. A  
McMASTER-CARR, Part  
Number 4464K473, have  
been found suitable.

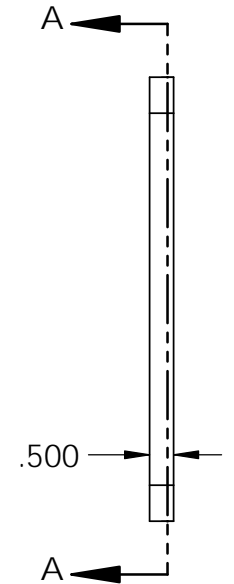
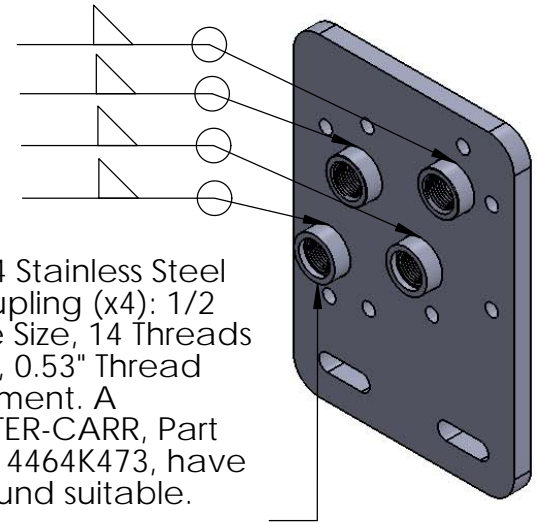

SOLIDWORKS Drawing Provided by  
Intertek Automotive Research

		UNLESS OTHERWISE SPECIFIED:			
		DIMENSIONS ARE IN INCHES			
		TOLERANCES:			
		THREE PLACE DECIMAL ± 0.002 in			
		MATERIAL TYPE 304 SS	COMMENTS:		
		DO NOT SCALE DRAWING			

TITLE:			Camaro Oil Cooler Plate - Sheet 1		
SIZE	DWG. NO.			REV	
<b>A</b>					
SCALE: 1:4	WEIGHT:			SHEET 1 OF 2	

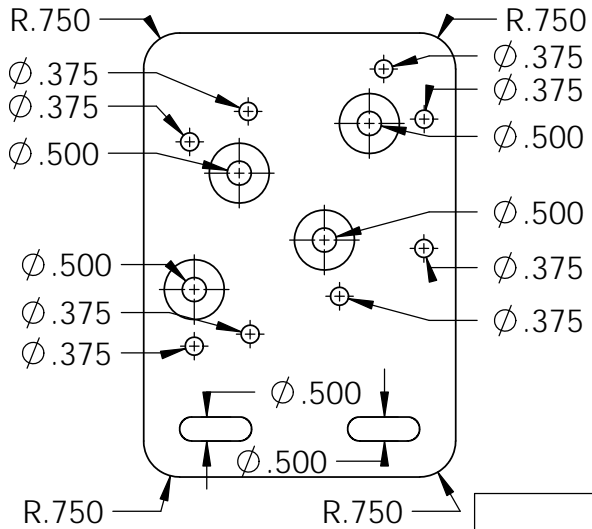
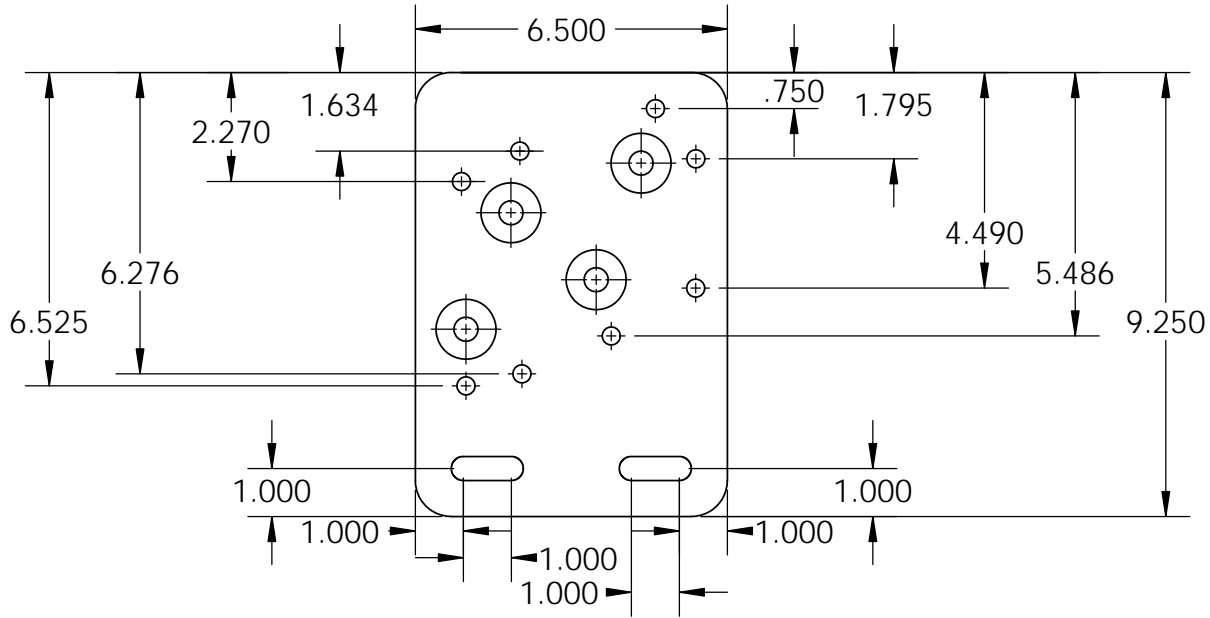

Note: Upon Completion of Welding the Half Couplings in Place, the Contact Surface between the Camaro Oil Cooler Plate and the Heat Exchanger will need to be End Milled Utilizing a Fly Cutter in Order to Ensure a Proper Sealing Contact Surface for the O-rings once Torqued to the Plate.

Milling

SOLIDWORKS Drawing Provided by  
Intertek Automotive Research

		UNLESS OTHERWISE SPECIFIED:			
		DIMENSIONS ARE IN INCHES TOLERANCES: THREE PLACE DECIMAL 0.002 in			
		INTERPRET GEOMETRIC TOLERANCING PER:			
		MATERIAL <b>TYPE 304 SS</b>		COMMENTS:	
		DO NOT SCALE DRAWING			
TITLE:			Camaro Oil Cooler Plate - Sheet 2		
SIZE	DWG. NO.		REV		
<b>A</b>					
SCALE: 1:4	WEIGHT:	SHEET 2 OF 2			

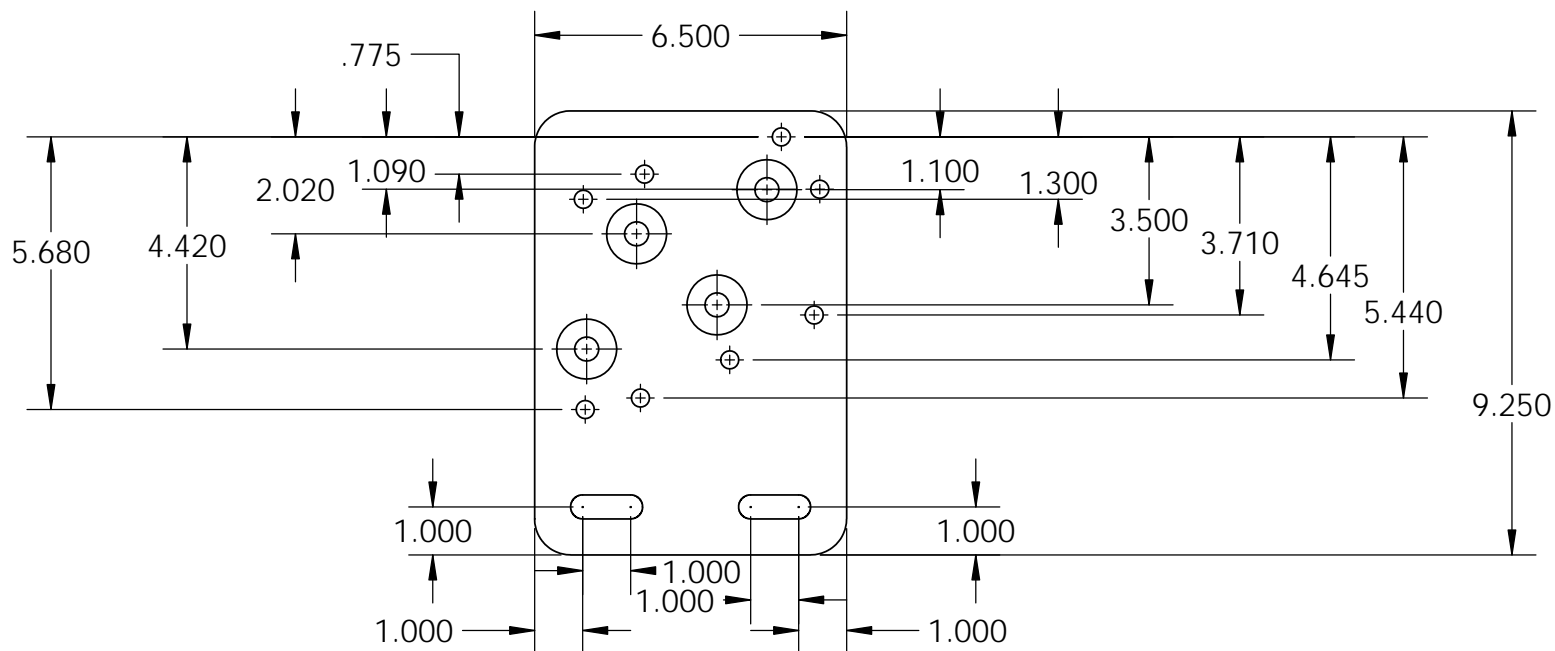

**PROPRIETARY AND CONFIDENTIAL**  
 THE INFORMATION CONTAINED IN THIS DRAWING IS THE SOLE PROPERTY OF <INSERT COMPANY NAME HERE>. ANY REPRODUCTION IN PART OR AS A WHOLE WITHOUT THE WRITTEN PERMISSION OF <INSERT COMPANY NAME HERE> IS PROHIBITED.

		UNLESS OTHERWISE SPECIFIED:		NAME	DATE	<b>TITLE:</b> Camaro Oil Cooler Plate - Sheet 2					
		DIMENSIONS ARE IN INCHES	DRAWN						<b>SIZE</b> <b>A</b>	<b>DWG. NO.</b>	<b>REV</b>
		TOLERANCES:	CHECKED								
		FRACTIONAL ±	ENG APPR.								
		ANGULAR: MACH ± BEND ±	MFG APPR.								
		TWO PLACE DECIMAL ±	Q.A.			<b>SCALE: 1:4</b>   <b>WEIGHT:</b>   <b>SHEET 1 OF 1</b>					
		THREE PLACE DECIMAL ±	COMMENTS:								
		INTERPRET GEOMETRIC TOLERANCING PER:									
		MATERIAL <b>TYPE 304 SS</b>									
		FINISH									
NEXT ASSY	USED ON										
APPLICATION		DO NOT SCALE DRAWING									

Top blue circle is the pressure location, the lower blue circle is the temperature location

DIAM	C	SURFACE	TOLERANCE
7	6	PIN	
7	H	PIN	

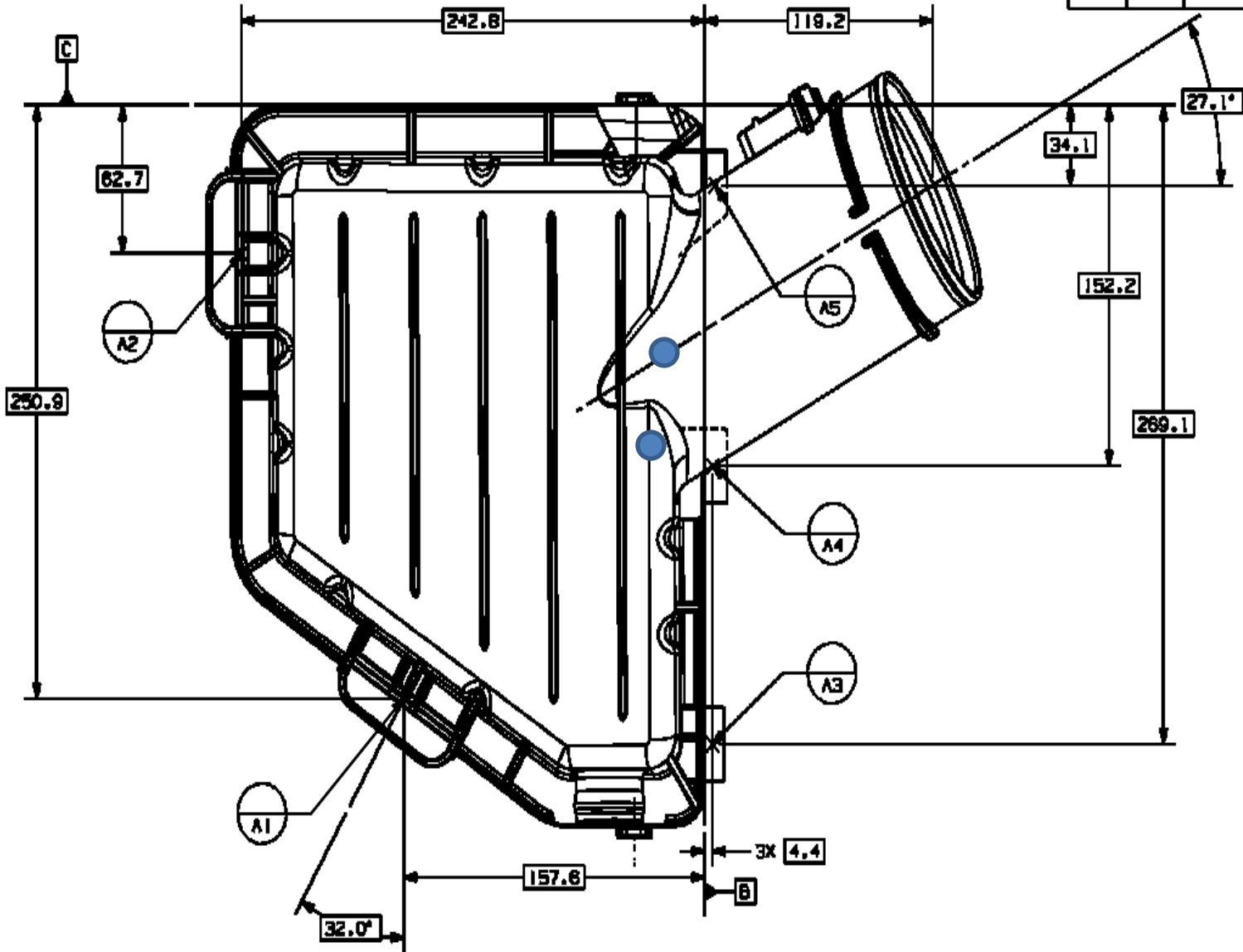



Since the datum points on this airbox are hole centers and the corners are rounded, I have chosen a groove molded into the cover as the reference point. The tip of the molded groove is one reference, and the other is the side of the groove closest to the holes.

The pressure probe and thermocouple are each installed to a depth of  $50 \pm 3$  mm.

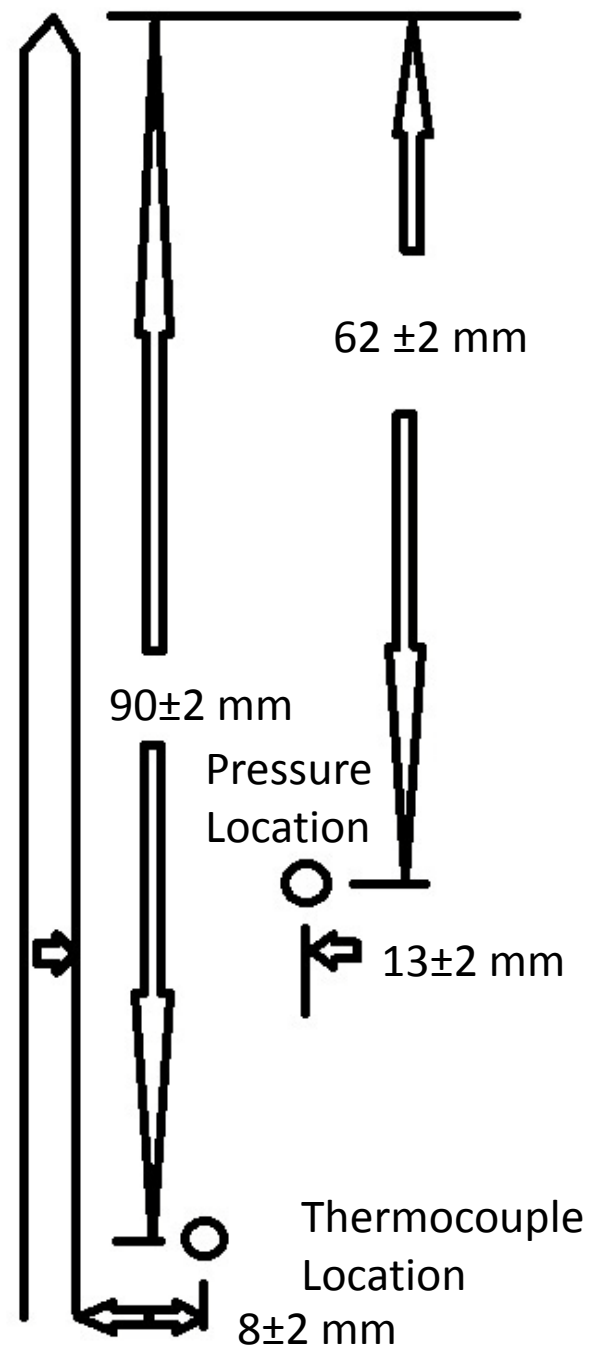

This probe design is commonly used in PCMO testing

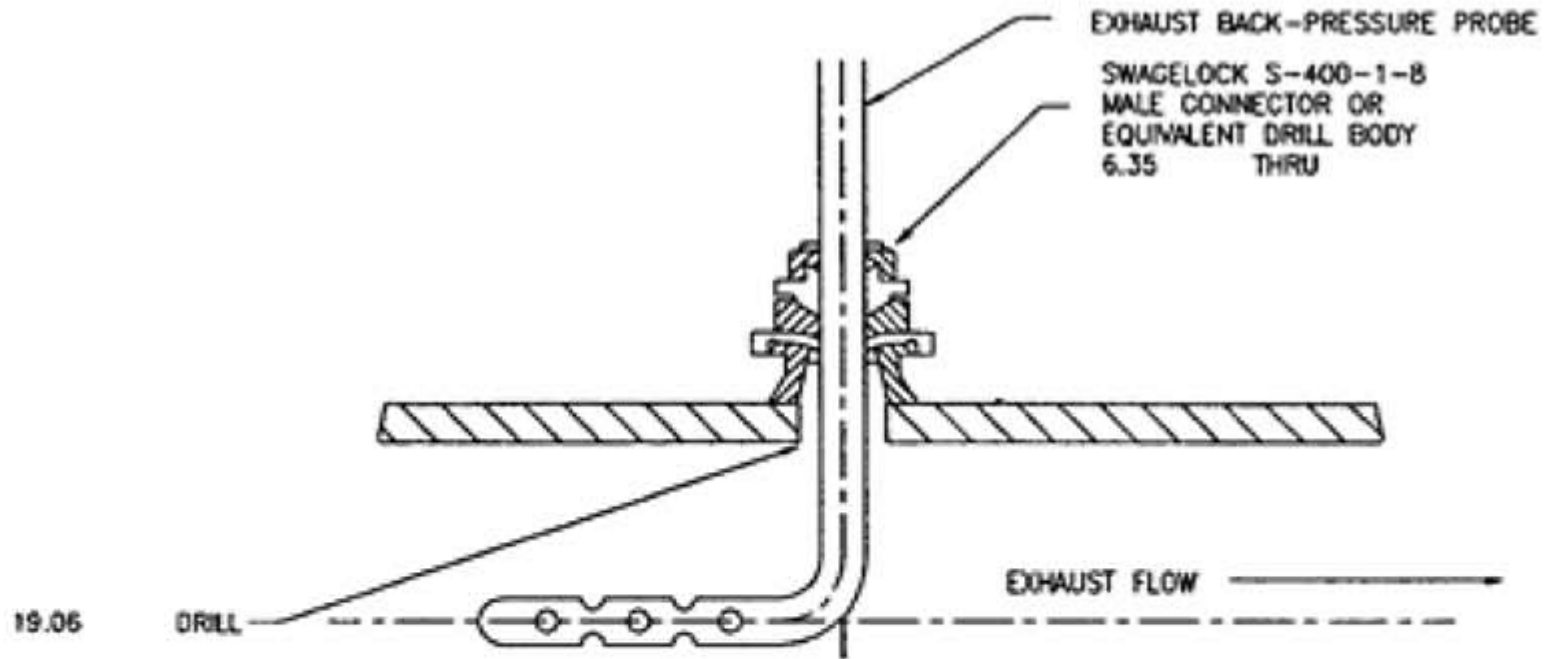

NOTE: BEND EXTERNAL TUBING  
SEGMENT AFTER ASS'Y PARALLEL  
WITH PROBE AXIS AS SHOWN.  
THIS PERMITS VISUAL ALIGNMENT  
CHECK DURING OPERATION.

ASSEMBLY DETAIL

**Measurements are in millimeters**

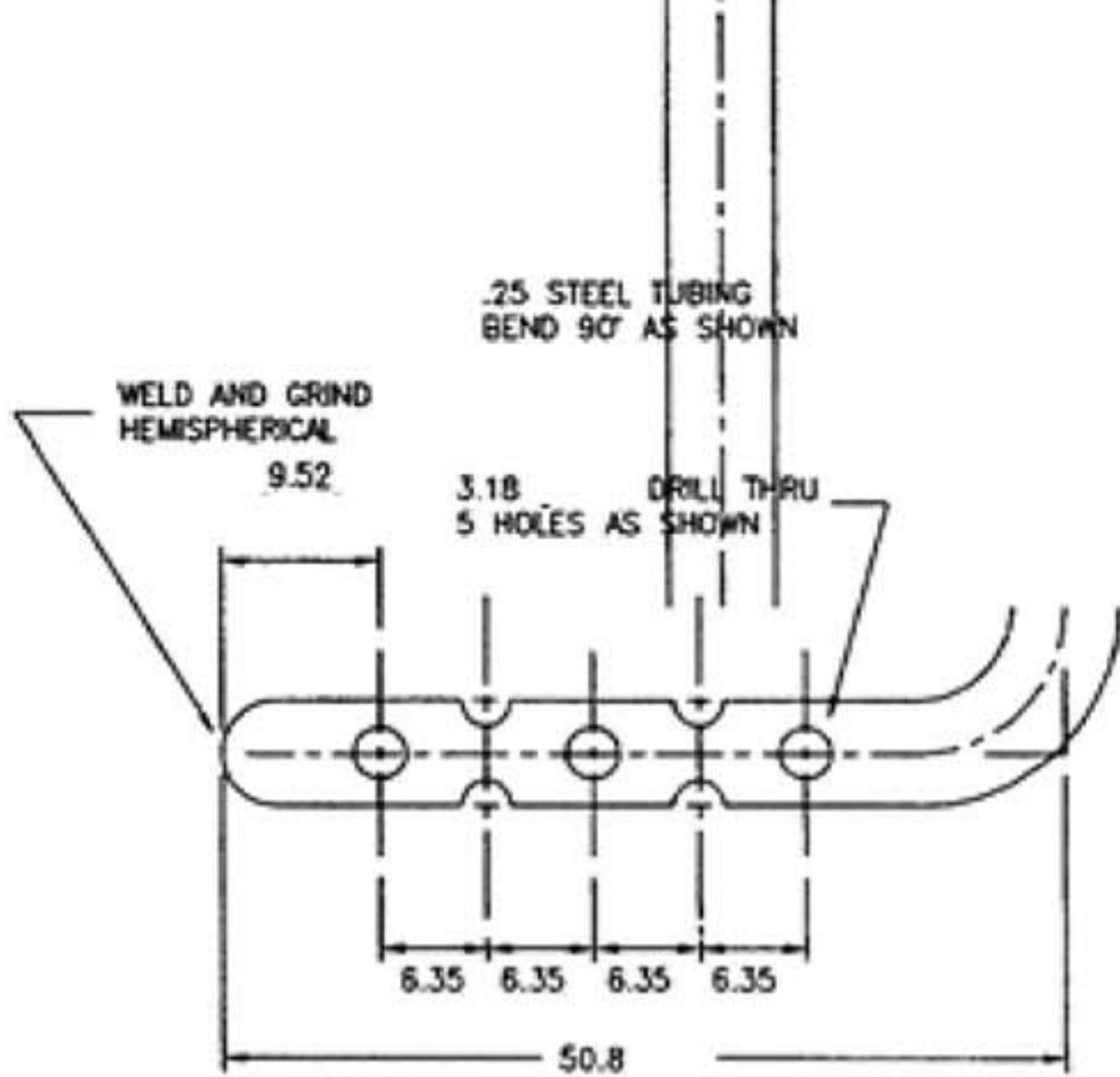

PROBE DETAIL

# Top of airbox



# Measurement for pressure tap





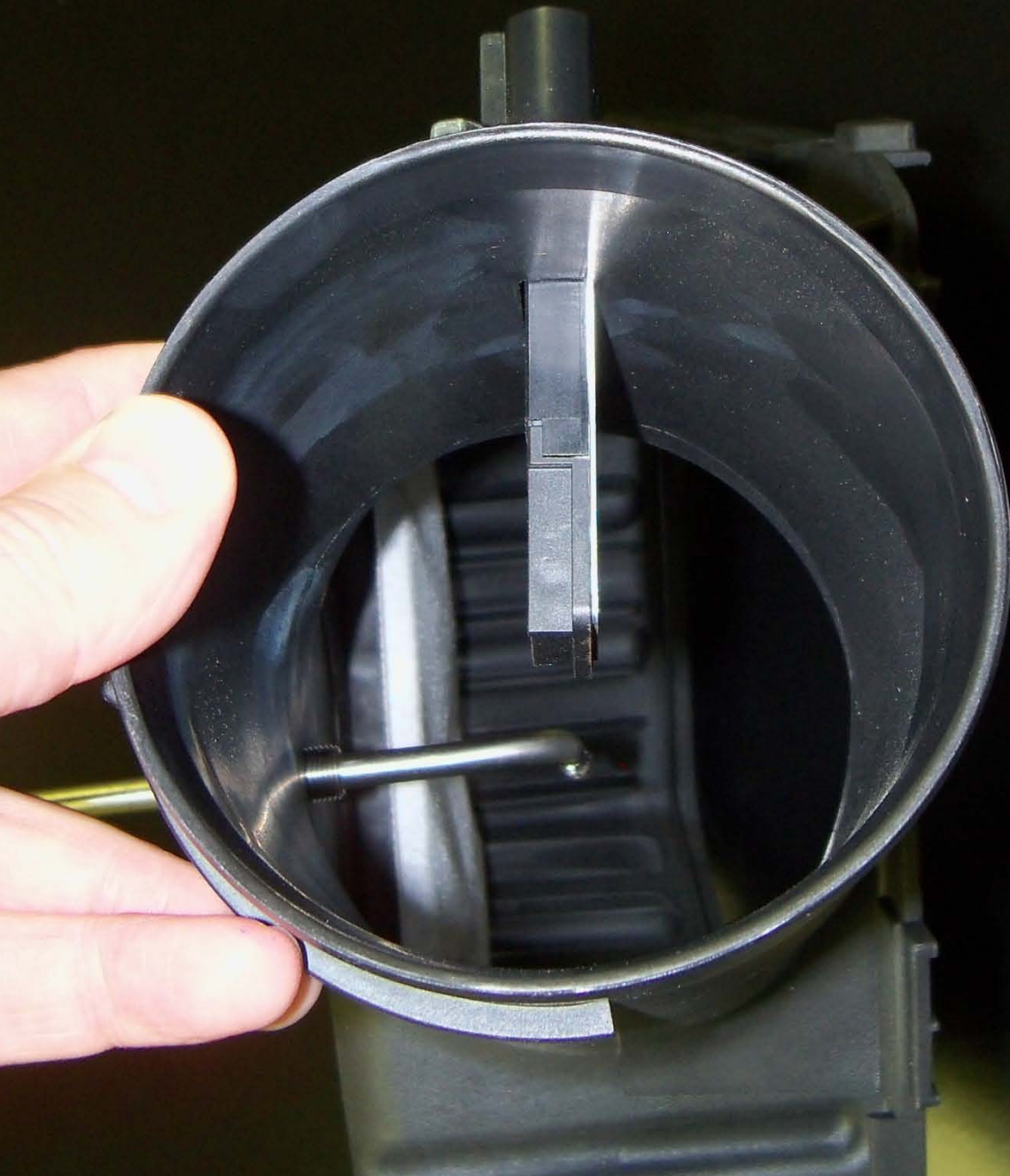

Thermocouple  
will be below  
the pressure  
sensor





REVISIONS				
REV	SHT	ZONE	DESCRIPTION	DATE

GENERAL NOTES

- 1) DO NOT SCALE THIS DRAWING
- 2) UNLESS OTHERWISE STATED:
  - a. ALL DIMENSIONING AND TOLERANCING IS IN INCHES PER ASME Y14.5-2009
  - b. BREAK ALL SHARP CORNERS AND SHARP EDGES R .010 MAXIMUM
  - c. MACHINED SURFACE FINISHES SHALL BE 125 MICROINCH OR BETTER
  - d. TAP DRILL DEPTHS SHOWN ARE MAXIMUM
  - e. FULL THREAD DEPTHS SHOWN ARE MINIMUM
  - f. CHAMFER ALL TAPED HOLES TO (NOMINAL DIA + 1/16) x 90°
- 3) FINISH:

Appendix D

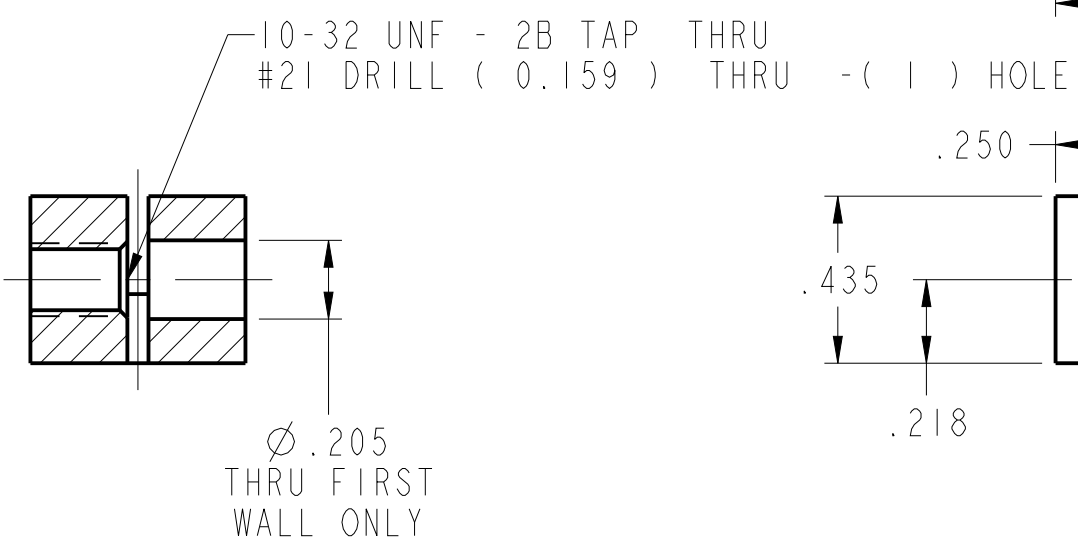
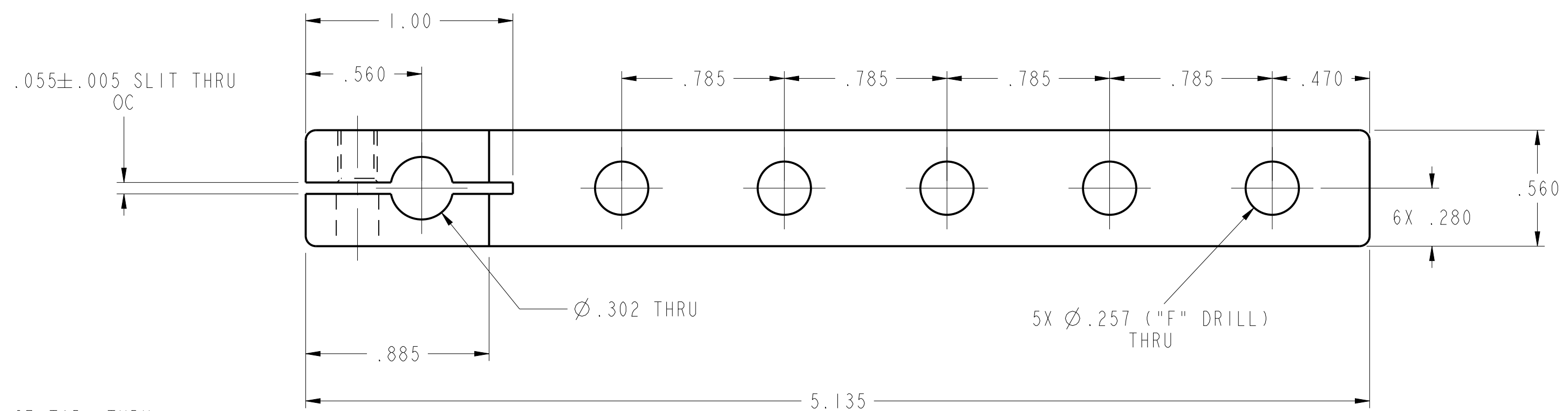
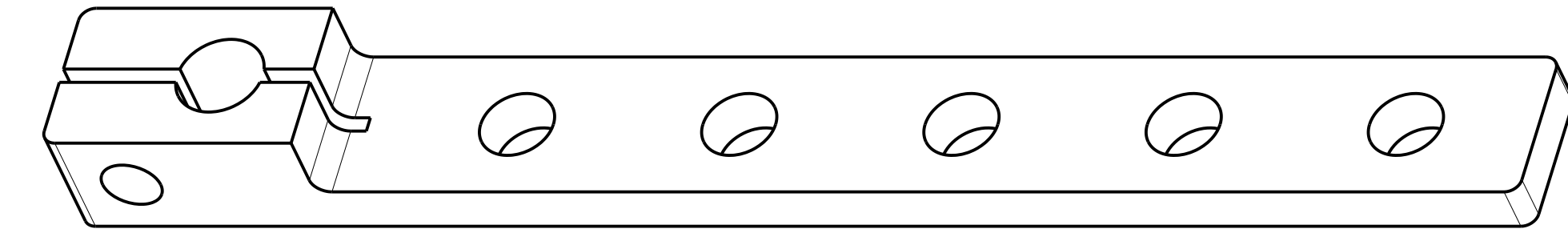

SECTION A-A

	-1	LEVER ARM	MILD STEEL	
-1	CAGE	PART NUMBER	DESCRIPTION	MATERIAL/SPECIFICATION/NOTES
BILL OF MATERIAL/PARTS LIST				
DEFAULT TOLERANCES		APPROVAL SIGNATURES		
ONE PLACE (X.X) = ± 0.1		DESIGNED BY		
TWO PLACES (X.XX) = ± 0.01		CHECKED BY		
THREE PLACES (X.XXX) = ± 0.005		DESIGNED BY		
FOUR PLACES (X.XXXX) = ± 0.0005		DESIGNED BY		
ANGLES = ± 0.5 DEGREE		DATE	COMPLETION DATE: 06 JAN 2014	
SURFACE FINISHES <= 125 MICROINCH RA		FILE	MODEL: THROTTLE_LEVER	
THIRD ANGLE PROJECTION		EXCEPT AS MAY OTHERWISE BE PROVIDED BY CONTRACT, THESE DIMENSIONS AND SPECIFICATIONS ARE THE PROPERTY OF SOUTHWEST RESEARCH INSTITUTE, ARE ISSUED IN STRICT CONFIDENCE, AND SHALL NOT BE REPRODUCED, OR COPIED, OR USED AS THE BASIS FOR MANUFACTURE OR SALE OF ANY APPARATUS SHOWN THEREON WITHOUT PERMISSION.		
			<b>SOUTHWEST RESEARCH INSTITUTE</b> OFFICE of AUTOMOTIVE ENGINEERING 6220 CULEBRA ROAD SAN ANTONIO, TEXAS 78238	
SCALE 2/1		UNIT WEIGHT = LBS		SHEET 1 OF 1

SwRI GMOD Exhaust pipe taps

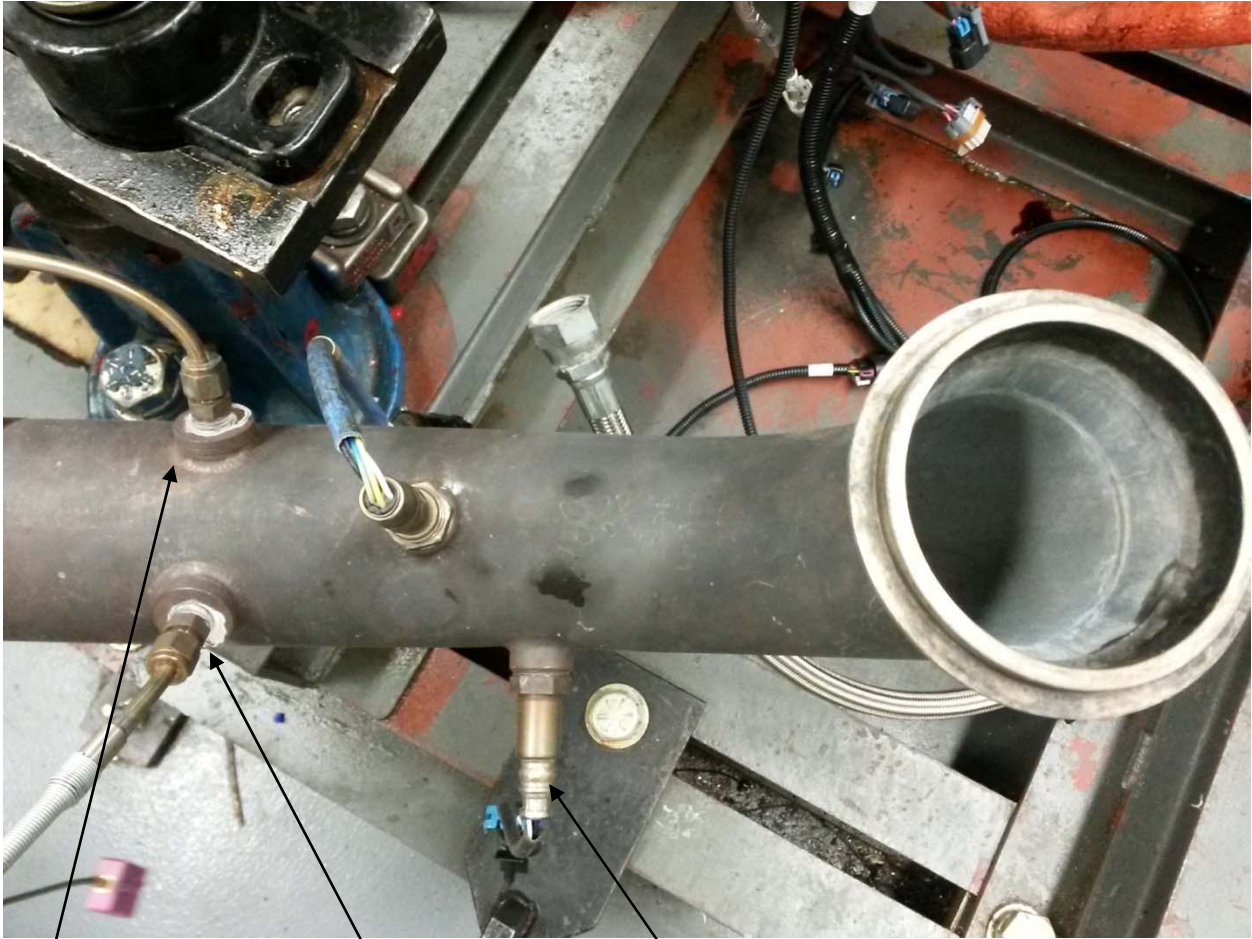

Exhaust Backpressure

Exhaust Temp

Stock Oxygen sensor

GENERAL NOTES

- 1) DO NOT SCALE THIS DRAWING
- 2) UNLESS OTHERWISE STATED:
  - a. ALL DIMENSIONING AND TOLERANCING IS IN INCHES PER ASME Y14.5-2009
  - b. BREAK ALL SHARP CORNERS AND SHARP EDGES R .010 MAXIMUM
  - c. MACHINED SURFACE FINISHES SHALL BE 125 MICROINCH OR BETTER
  - d. TAP DRILL DEPTHS SHOWN ARE MAXIMUM
  - e. FULL THREAD DEPTHS SHOWN ARE MINIMUM
  - f. CHAMFER ALL TAPED HOLES TO (NOMINAL DIA + 1/16) x 90°
- 3) FINISH:

REVISIONS				
REV	SHT	ZONE	DESCRIPTION	DATE

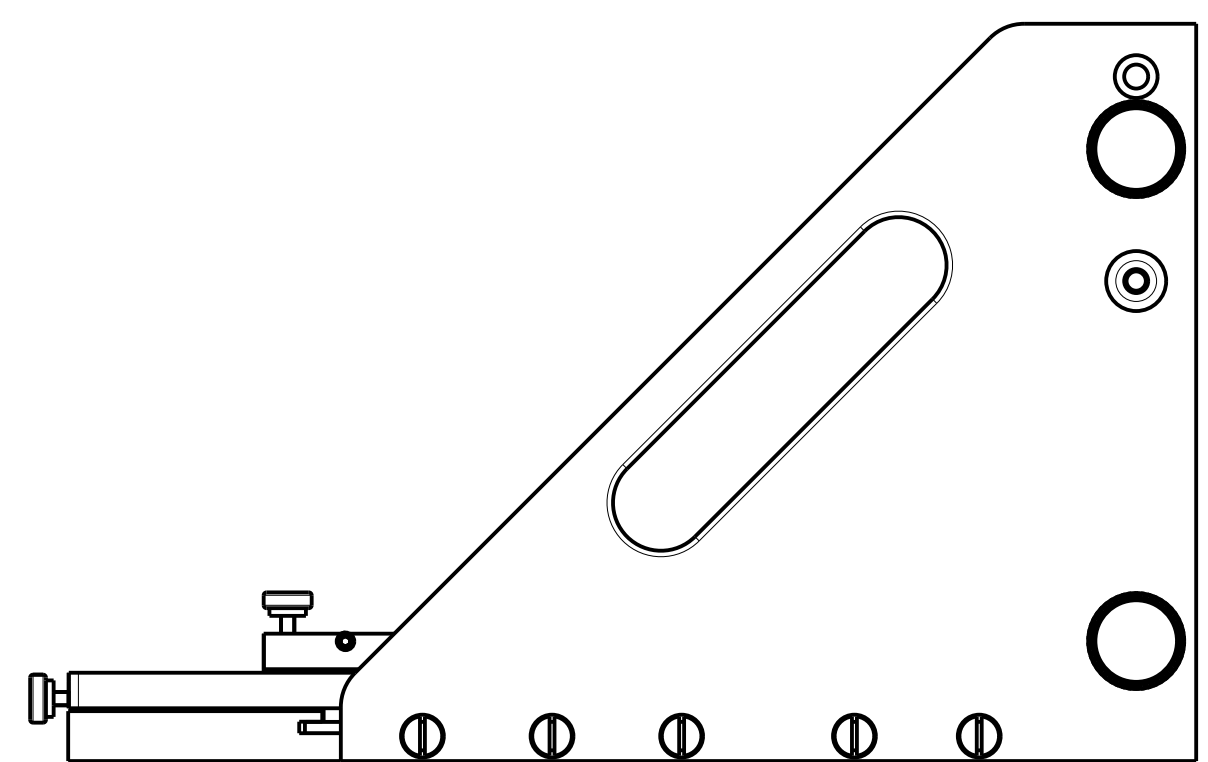
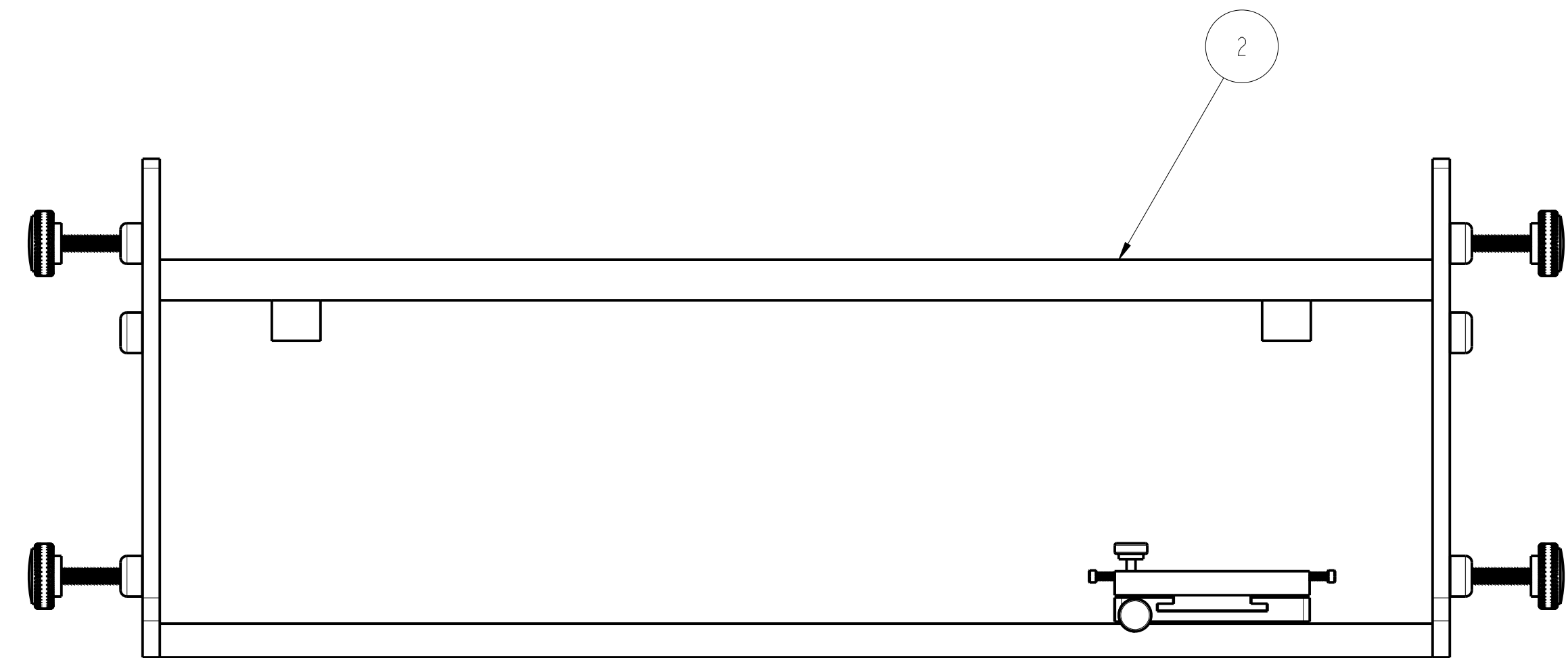
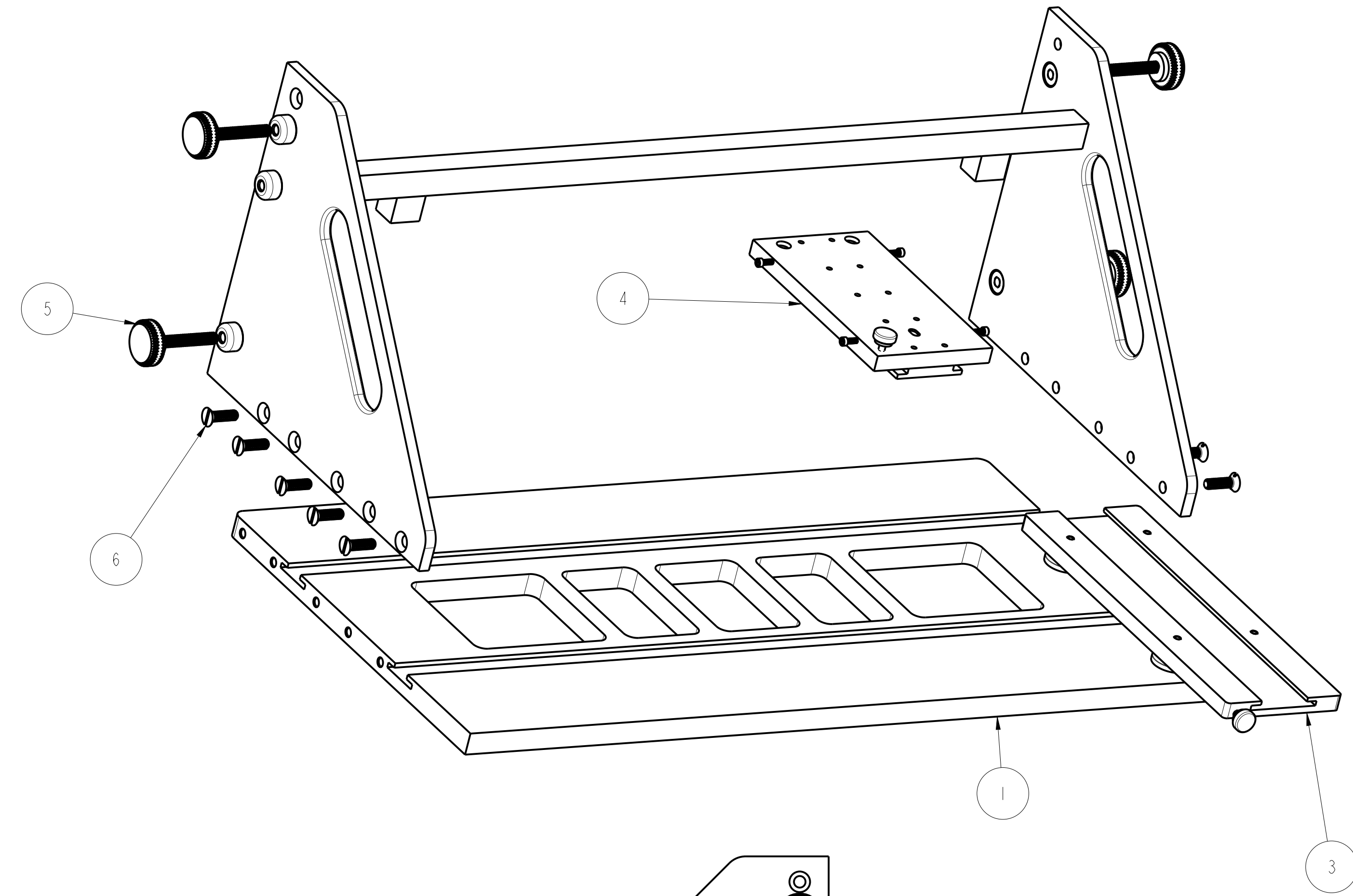
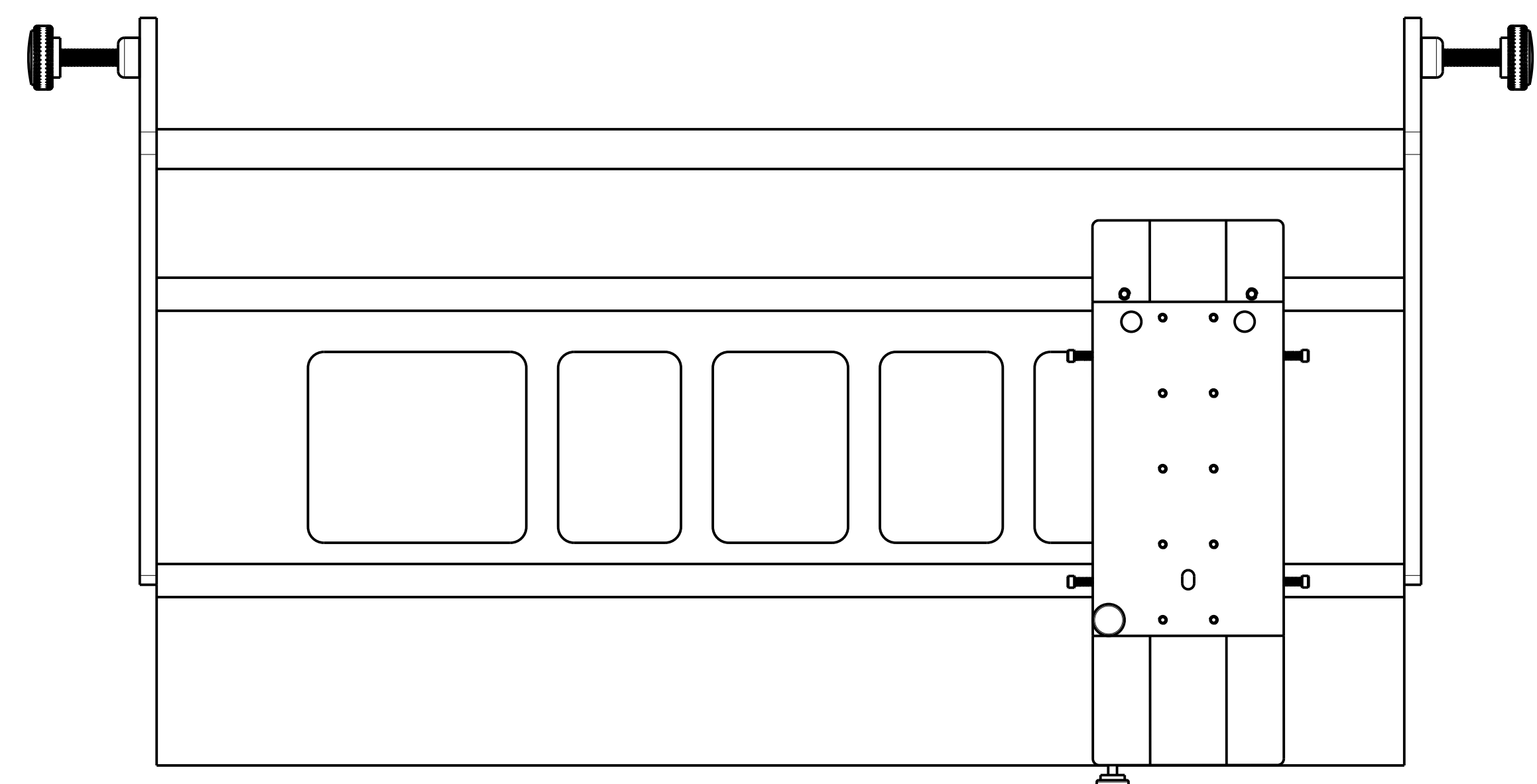

QTY	CAGE	PART NUMBER	DESCRIPTION	MATERIAL/SPECIFICATION/NOTES	ITEM
10			Ø12-24 UNC FLAT HEAD SCREW		6
4			LOCK KNOB		5
1		01910-431-300-000	ANALYZER MOUNT		4
1		01910-431-200-000	ANALYZER SLIDE CRADLE		3
1		01910-431-100-000	SLIDE PLATE WELDMENT		2
1		01910-431-000-001	SLIDE PLATE MOUNT	ANALYZER FIXTURE SIDE PLATE	1

DEFAULT TOLERANCES ONE PLACE (X.X) = ± 0.1 TWO PLACES (X.XX) = ± 0.01 THREE PLACES (X.XXX) = ± 0.005 FOUR PLACES (X.XXXX) = ± 0.0005 ANGLES = ± 0.5 DEGREE SURFACE FINISHES <= 125 MICROINCH RA		APPROVAL SIGNATURES DESIGNED BY: T. HABY CHECKED BY: P. LANG DRAWN BY: LANG/CASTANO DATE COMPLETION: FILE MODEL: ANALYZER_FIXTURE_MAIN		SOUTHWEST RESEARCH INSTITUTE OFFICE of AUTOMOTIVE ENGINEERING 6220 CULEBRA ROAD SAN ANTONIO, TEXAS 78238 <b>ANALYZER FIXTURE MAIN ASSEMBLY</b>	
THIRD ANGLE PROJECTION 		EXCEPT AS MAY OTHERWISE BE PROVIDED BY CONTRACT, THESE DIMENSIONS AND SPECIFICATIONS ARE THE PROPERTY OF SOUTHWEST RESEARCH INSTITUTE, ARE ISSUED IN STRICT CONFIDENCE, AND SHALL NOT BE REPRODUCED, OR COPIED, OR USED AS THE BASIS FOR MANUFACTURE OR SALE OF ANY APPARATUS SHOWN HEREON WITHOUT PERMISSION.		SCALE 1/2 UNIT WEIGHT = LBS SHEET 1 OF 1	

D  
C  
B  
A

D  
C  
B  
A

REVISIONS				
REV	SHT	ZONE	DESCRIPTION	DATE
A			INITIAL RELEASE	01 NOV 2013

GENERAL NOTES  
 1) DO NOT SCALE THIS DRAWING  
 2) UNLESS OTHERWISE STATED:  
 a. ALL DIMENSIONING AND TOLERANCING IS IN INCHES PER ASME Y14.5-2009  
 b. BREAK ALL SHARP CORNERS AND SHARP EDGES R .010 MAXIMUM  
 c. MACHINED SURFACE FINISHES SHALL BE 125 MICROINCH OR BETTER  
 d. TAP DRILL DEPTHS SHOWN ARE MAXIMUM  
 e. FULL THREAD DEPTHS SHOWN ARE MINIMUM  
 f. CHAMFER ALL TAPED HOLES TO (NOMINAL DIA + 1/16) x 90°  
 3) FINISH:

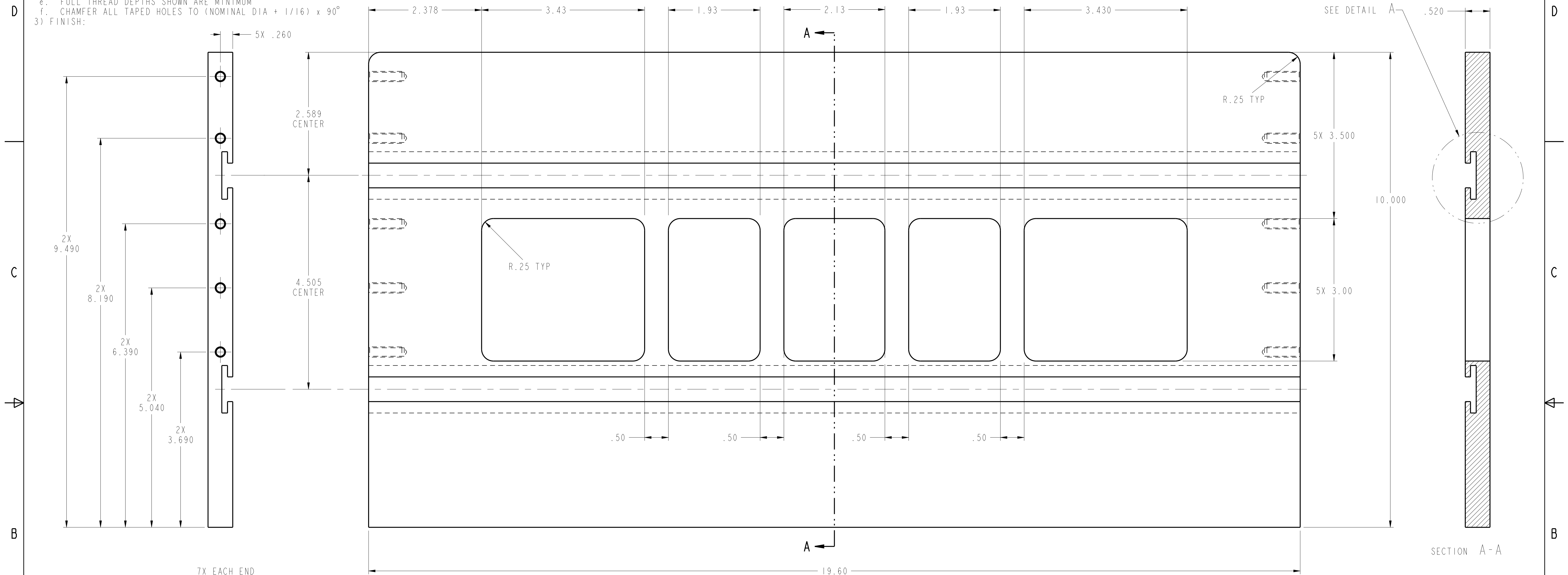

7X EACH END  
 Ø12-24 UNC-2B TAP 0.85  
 DRILL ⚭ 1.00

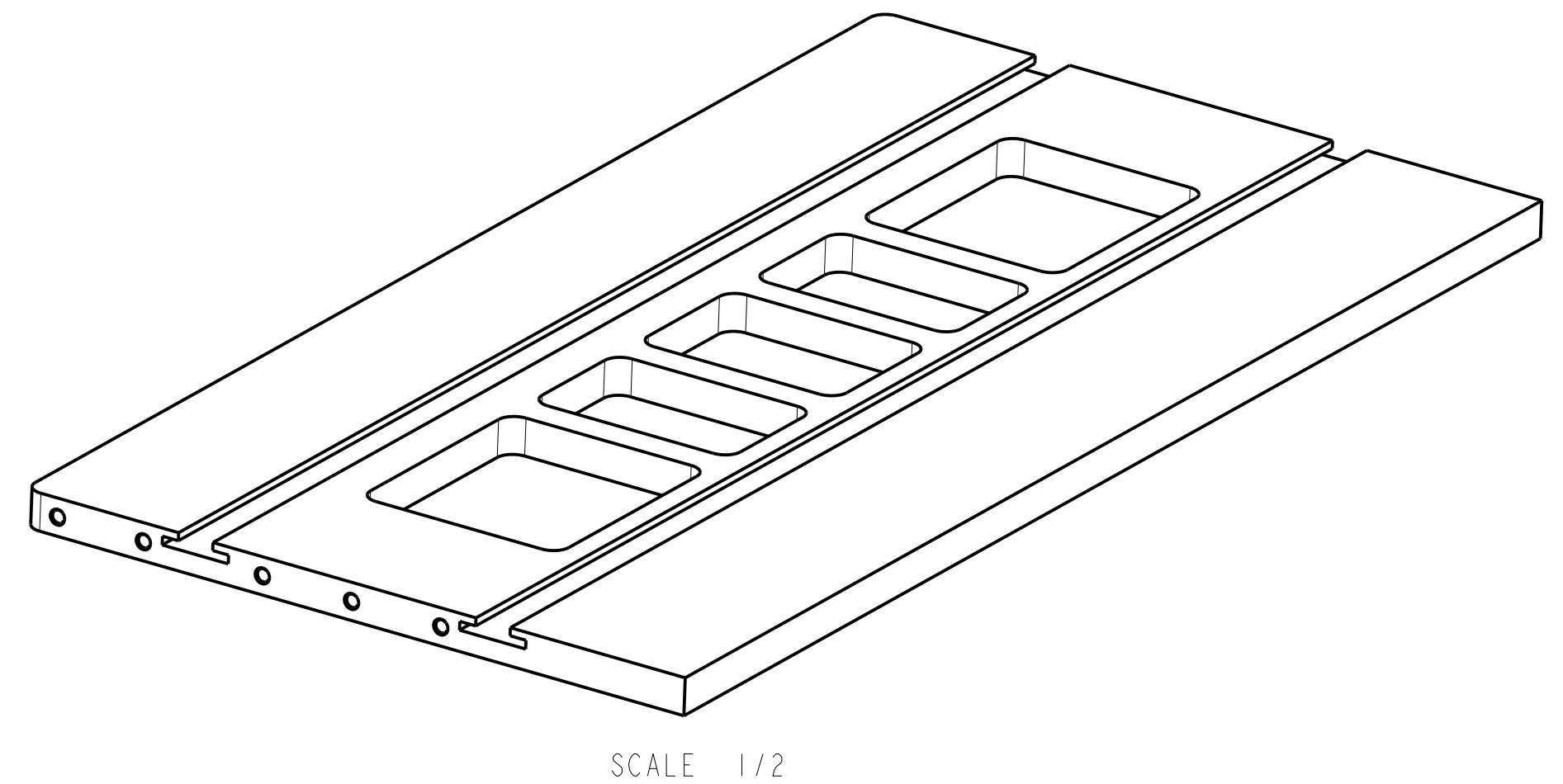
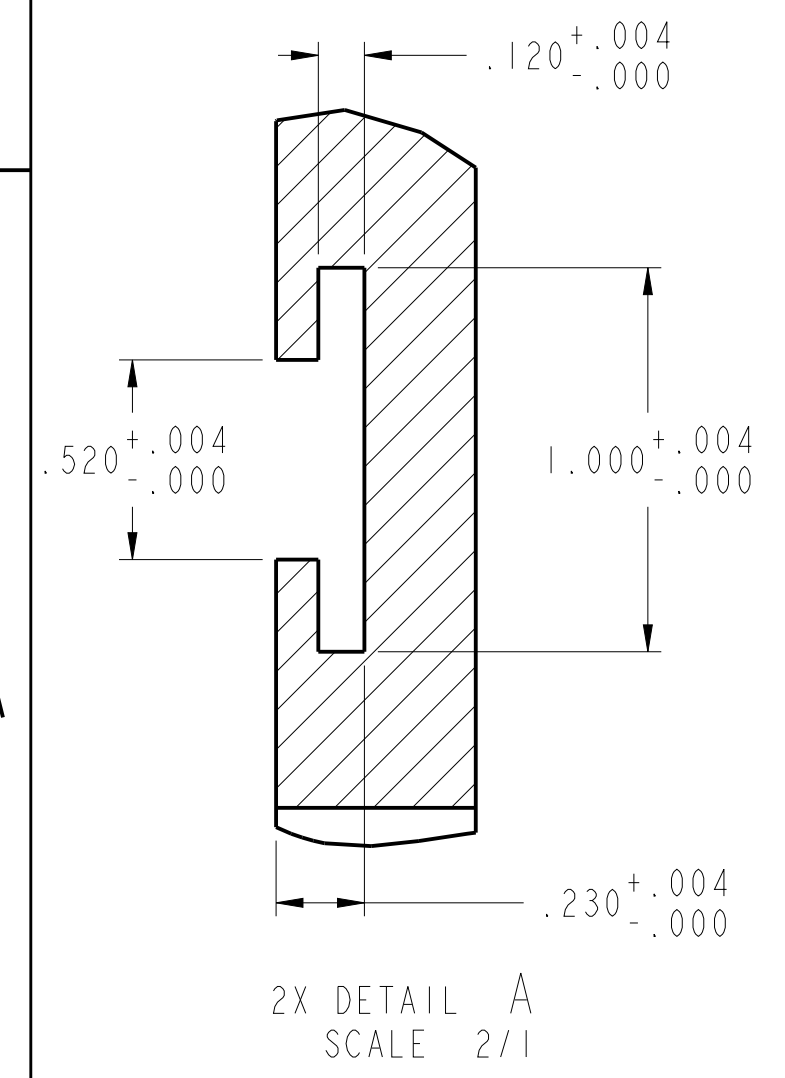

		-1		6061-T6 ALUMINUM	I
-1	CAGE	PART NUMBER	DESCRIPTION	MATERIAL/SPECIFICATION/NOTES	ITEM
BILL OF MATERIAL/PARTS LIST					
DEFAULT TOLERANCES			APPROVAL SIGNATURES		
ONE PLACE (X.X) = ± 0.1			DESIGNER: T. HABY		
TWO PLACES (X.XX) = ± 0.01			CHECKER: LANG/CASTANO		
THREE PLACES (X.XXX) = ± 0.005			DRAWN: J. CASTANO		
FOUR PLACES (X.XXXX) = ± 0.0005			PROJ: P. LANG		
ANGLES = ± 0.5 DEGREE			DATE COMPLETION DATE:		
SURFACE FINISHES <= 125 MICROINCH RA			FILE MODEL: FIXTURE_SLIDE_PLATE		
THIRD ANGLE PROJECTION			EXCEPT AS MAY OTHERWISE BE PROVIDED BY CONTRACT, THESE DIMENSIONS AND SPECIFICATIONS ARE THE PROPERTY OF SOUTHWEST RESEARCH INSTITUTE, ARE ISSUED IN STRICT CONFIDENCE, AND SHALL NOT BE REPRODUCED, OR COPIED, OR USED AS THE BASIS FOR MANUFACTURE OR SALE OF ANY APPARATUS SHOWN THEREON WITHOUT PERMISSION.		
SHEET NUMBER: D		PART NUMBER: 26401		ITEM NUMBER: 01910-431-000-001	
SCALE 1/1		UNIT WEIGHT = LBS		SHEET 1 OF 1	

**SOUTHWEST RESEARCH INSTITUTE**  
 OFFICE of AUTOMOTIVE ENGINEERING  
 6220 CULEBRA ROAD SAN ANTONIO, TEXAS 78238

**FIXTURE SLIDE PLATE**

REVISIONS				
REV	SHT	ZONE	DESCRIPTION	DATE
A			INITIAL RELEASE	01 NOV 2013

GENERAL NOTES

- 1) DO NOT SCALE THIS DRAWING
- 2) UNLESS OTHERWISE STATED:
  - a. ALL DIMENSIONING AND TOLERANCING IS IN INCHES PER ASME Y14.5-2009
  - b. BREAK ALL SHARP CORNERS AND SHARP EDGES R .010 MAXIMUM
  - c. MACHINED SURFACE FINISHES SHALL BE 125 MICROINCH OR BETTER
  - d. TAP DRILL DEPTHS SHOWN ARE MAXIMUM
  - e. FULL THREAD DEPTHS SHOWN ARE MINIMUM
  - f. CHAMFER ALL TAPED HOLES TO (NOMINAL DIA + 1/16) x 90°
- 3) FINISH:

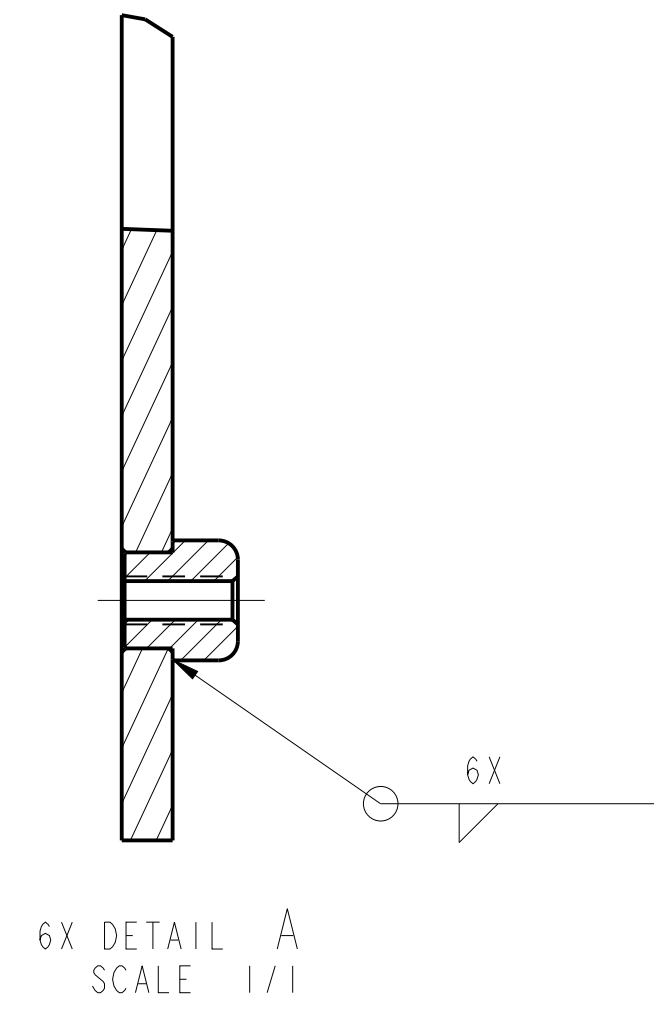
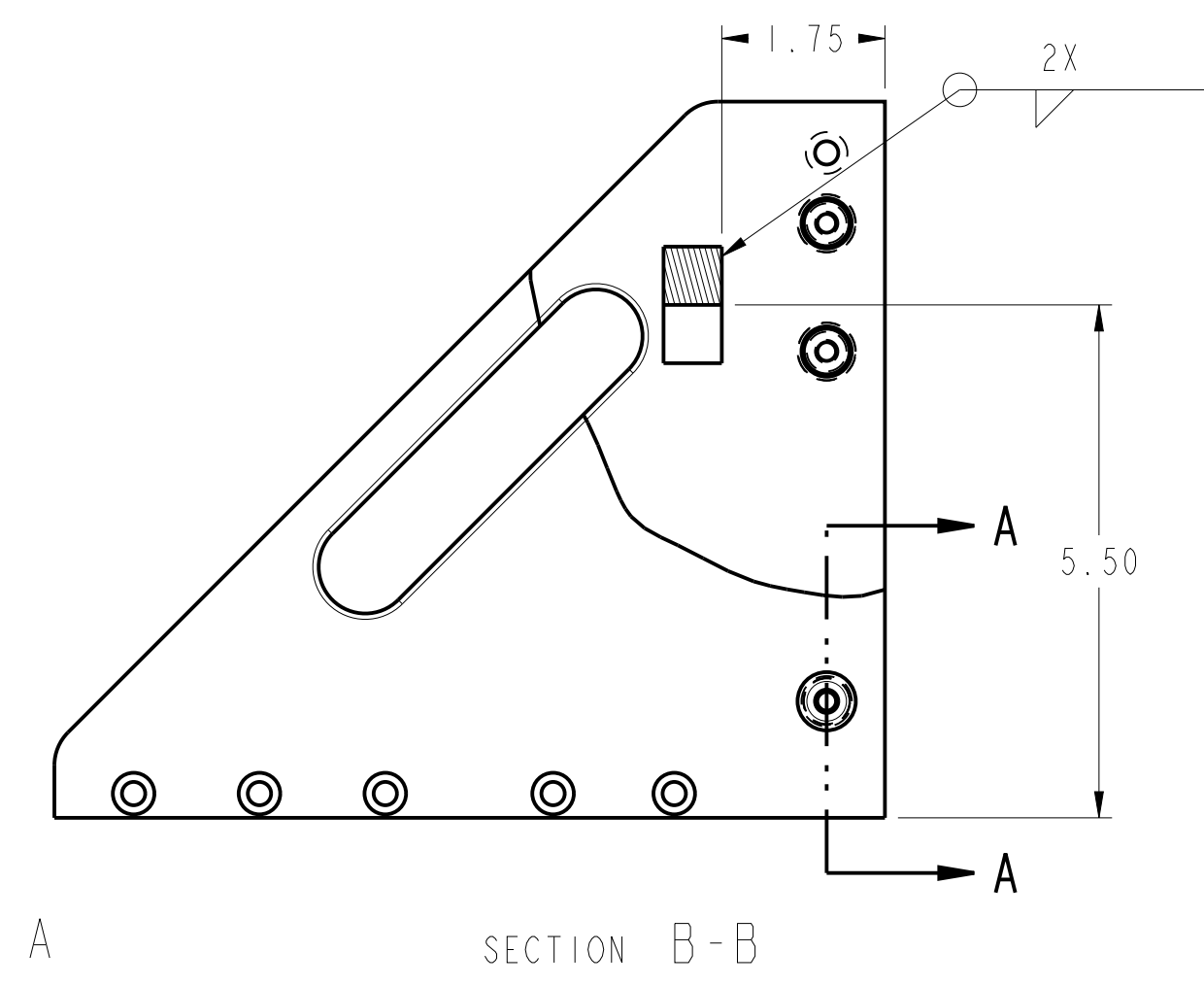
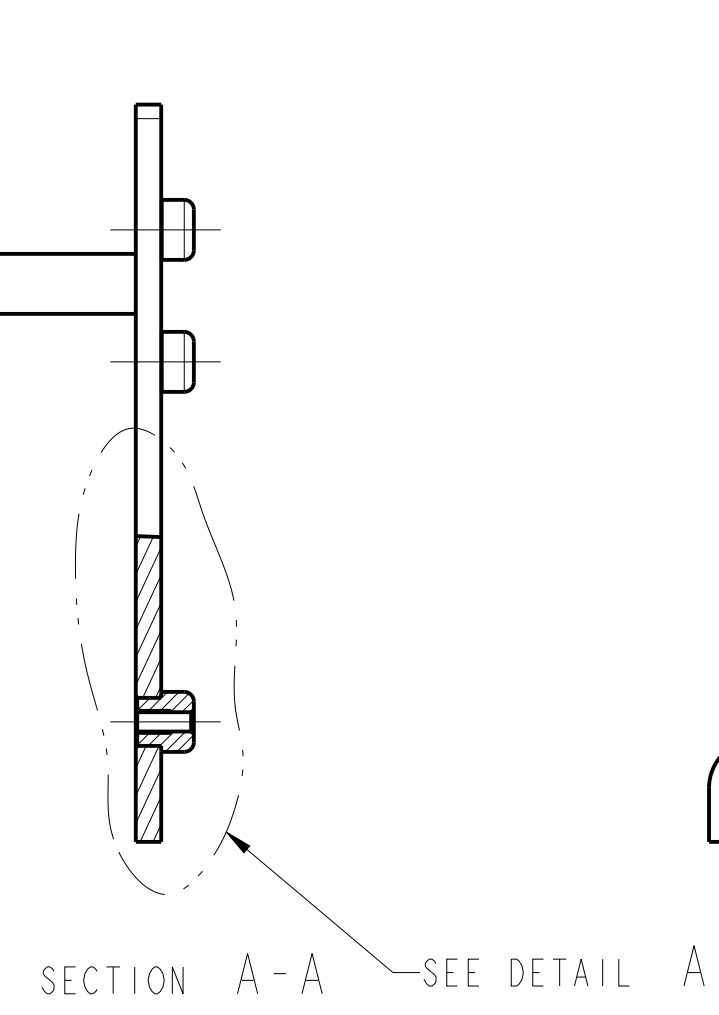
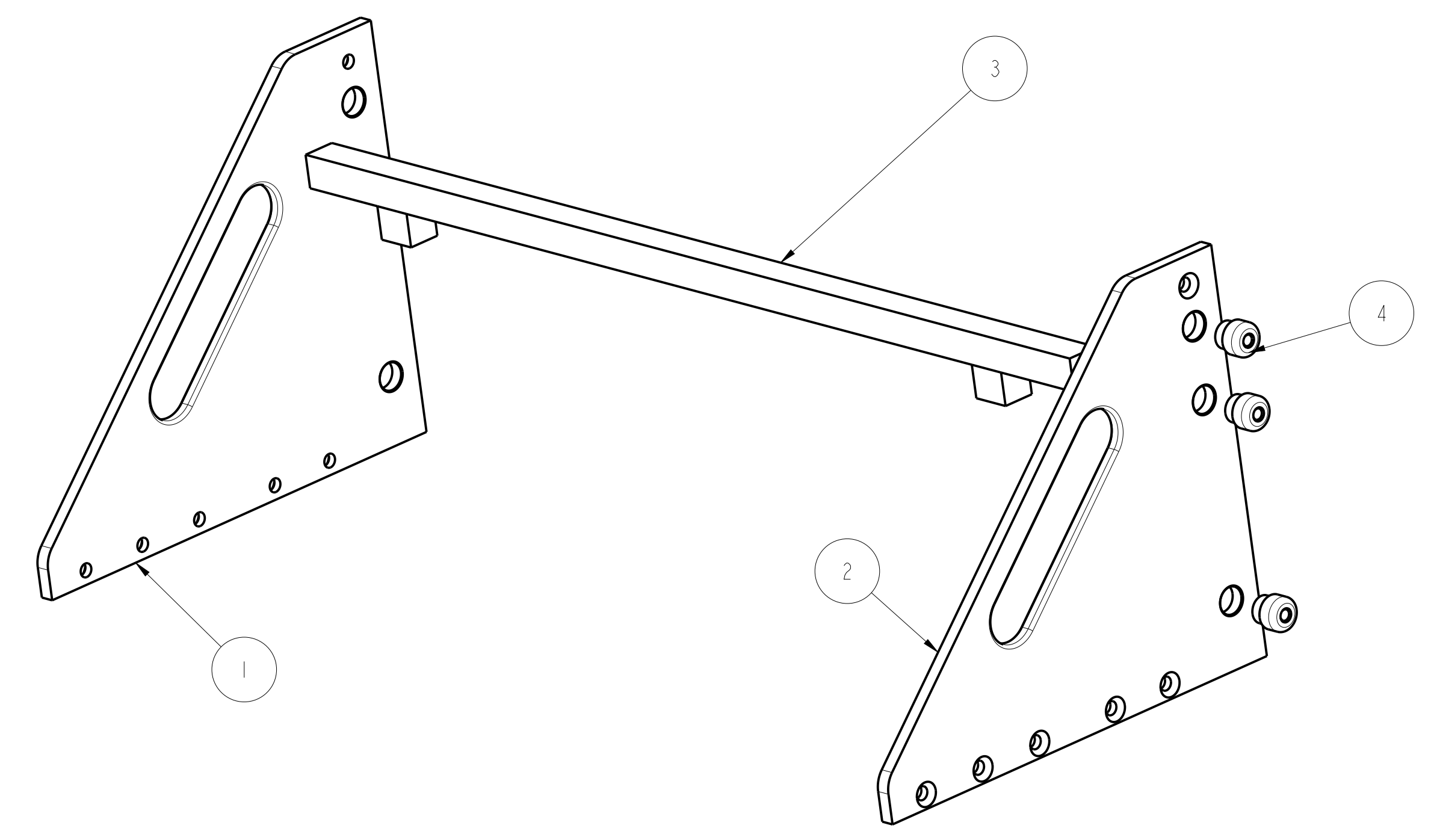
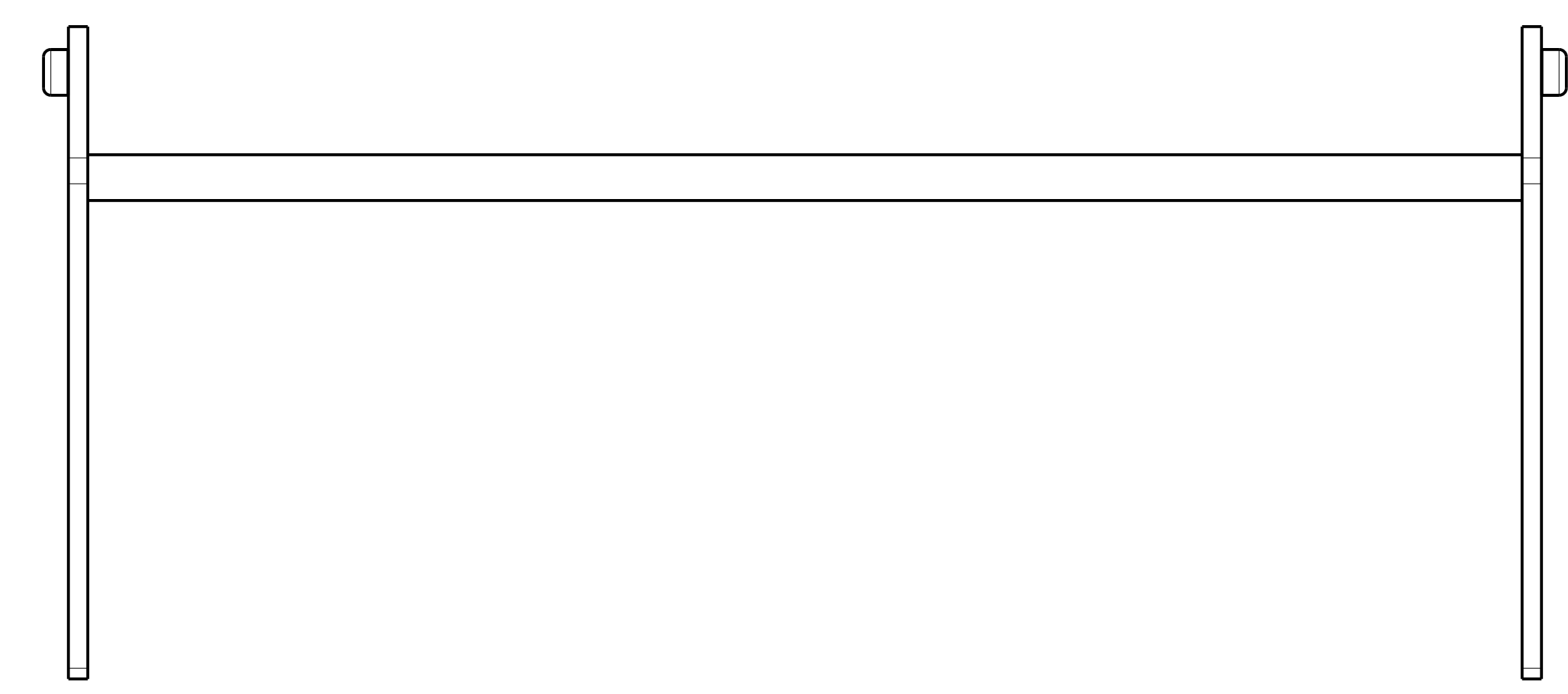

QTY	CAGE	PART NUMBER	DESCRIPTION	MATERIAL/SPECIFICATION/NOTES	ITEM
6		01910-431-100-004	SIDE PLATE BOSS		4
1		01910-431-100-003	SIDE PLATE SPACER BAR		3
1		01910-431-100-002	SIDE PLATE RIGHT		2
1		01910-431-100-001	SIDE PLATE LEFT		1

BILL OF MATERIAL/PARTS LIST			
DEFAULT TOLERANCES		APPROVAL SIGNATURES	
ONE PLACE (X.X) = ± 0.1	DESIGNER: T. HABY		
TWO PLACES (X.XX) = ± 0.01	CHK: P. LANG		
THREE PLACES (X.XXX) = ± 0.005	DRG: LANG/CASTNO		
FOUR PLACES (X.XXXX) = ± 0.0005	PROJ: LANG/CASTNO		
ANGLES = ± 0.5 DEGREE	DATE COMPLETION DATE:		
SURFACE FINISHES <= 125 MICROINCH RA	FILE MODEL: SIDE_PLATE_WELDMENT		
THIRD ANGLE PROJECTION		EXCEPT AS MAY OTHERWISE BE PROVIDED BY CONTRACT, THESE DRAWINGS AND SPECIFICATIONS ARE THE PROPERTY OF SOUTHWEST RESEARCH INSTITUTE, ARE ISSUED IN STRICT CONFIDENCE, AND SHALL NOT BE REPRODUCED, OR COPIED, OR USED AS THE BASIS FOR MANUFACTURE OR SALE OF ANY APPARATUS SHOWN THEREON WITHOUT PERMISSION.	
		<b>SOUTHWEST RESEARCH INSTITUTE</b> OFFICE of AUTOMOTIVE ENGINEERING 6220 CULEBRA ROAD SAN ANTONIO, TEXAS 78238	
<b>ANALYZER SIDE PLATE WELDMENT</b>			
REV: D	CAGE: 26401	PART NUMBER: 01910-431-100-000	REV: A
SCALE 1/2		UNIT WEIGHT = LBS	SHEET 1 OF 1

REVISIONS				
REV	SHT	ZONE	DESCRIPTION	DATE
A			INITIAL RELEASE	01 NOV 2013

GENERAL NOTES

- 1) DO NOT SCALE THIS DRAWING
- 2) UNLESS OTHERWISE STATED:
  - a. ALL DIMENSIONING AND TOLERANCING IS IN INCHES PER ASME Y14.5-2009
  - b. BREAK ALL SHARP CORNERS AND SHARP EDGES R .010 MAXIMUM
  - c. MACHINED SURFACE FINISHES SHALL BE 125 MICROINCH OR BETTER
  - d. TAP DRILL DEPTHS SHOWN ARE MAXIMUM
  - e. FULL THREAD DEPTHS SHOWN ARE MINIMUM
  - f. CHAMFER ALL TAPED HOLES TO (NOMINAL DIA + 1/16) x 90°
- 3) FINISH:

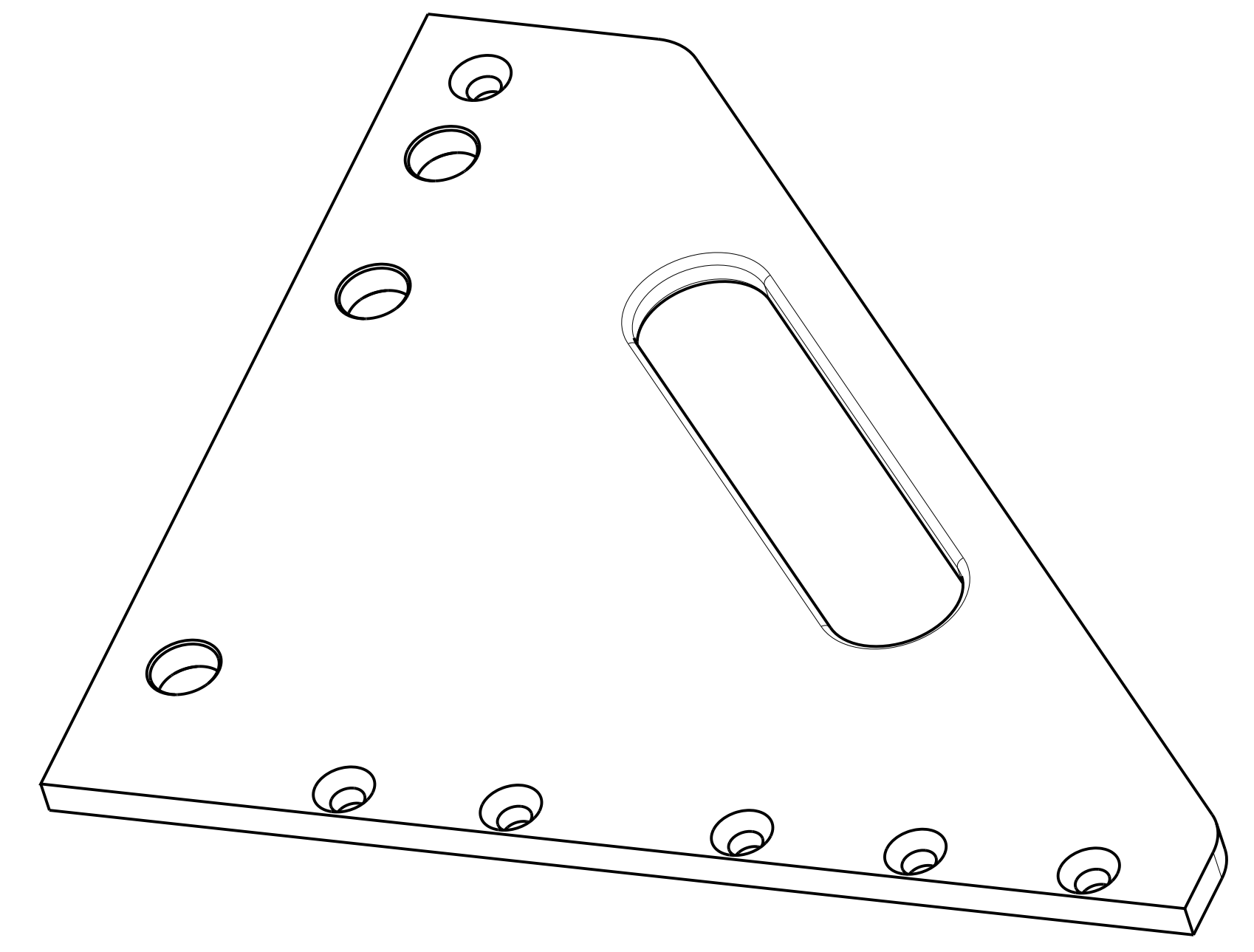
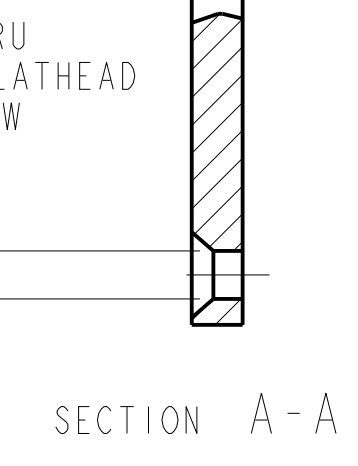
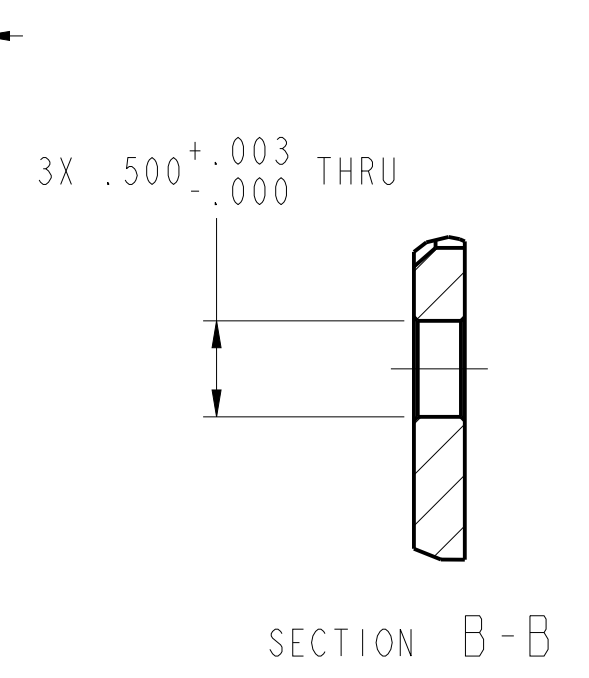
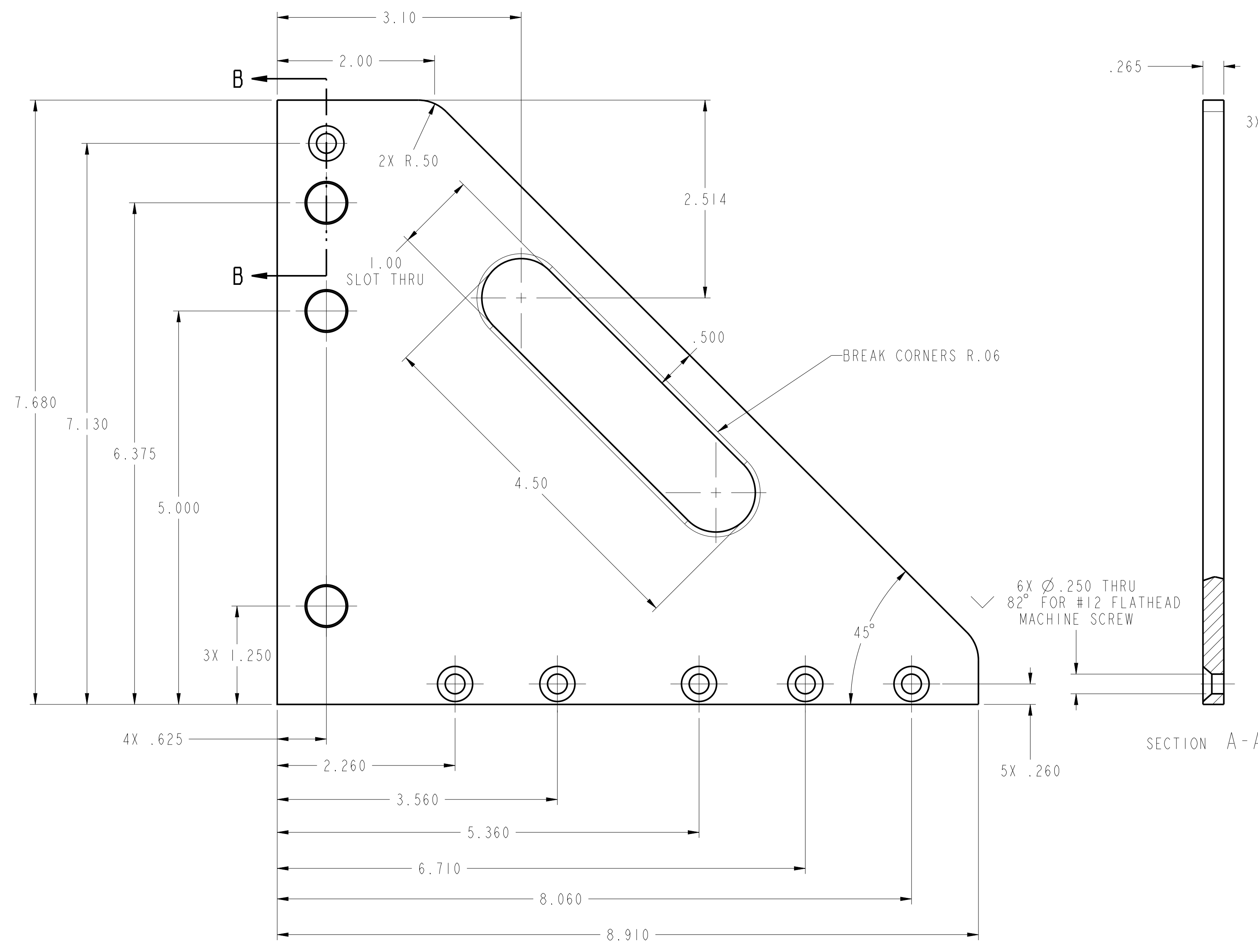

-1	-1	SIDE PLATE	6061-T6 ALUMINUM	I
-1	CAGE	PART NUMBER	DESCRIPTION	MATERIAL/SPECIFICATION/NOTES
BILL OF MATERIAL/PARTS LIST				
DEFAULT TOLERANCES		APPROVAL SIGNATURES		
ONE PLACE (X.X) = ± 0.1	DESIGNER	APPROVED		
TWO PLACES (X.XX) = ± 0.01	CHKD	DATE		
THREE PLACES (X.XXX) = ± 0.005	DRN	FILE		
FOUR PLACES (X.XXXX) = ± 0.0005	APPD	MODEL		
ANGLES = ± 0.5 DEGREE	DATE	COMPLETION DATE:		
SURFACE FINISHES <= 125 MICROINCH RA	FILE	MODEL: SIDE_BRACE_LEFT		
THIRD ANGLE PROJECTION		EXCEPT AS MAY OTHERWISE BE PROVIDED BY CONTRACT, THESE DIMENSIONS AND SPECIFICATIONS ARE THE PROPERTY OF SOUTHWEST RESEARCH INSTITUTE, ARE ISSUED IN STRICT CONFIDENCE, AND SHALL NOT BE REPRODUCED, OR COPIED, OR USED AS THE BASIS FOR MANUFACTURE OR SALE OF ANY APPARATUS SHOWN HEREON WITHOUT PERMISSION.		
		<b>SOUTHWEST RESEARCH INSTITUTE</b> OFFICE of AUTOMOTIVE ENGINEERING 6220 CULEBRA ROAD SAN ANTONIO, TEXAS 78238		
SCALE 1/1 UNIT WEIGHT = LBS SHEET 1 OF 1		SIDE PLATE, LEFT D 26401 01910-431-100-001 A		

REVISIONS				
REV	SHT	ZONE	DESCRIPTION	DATE
A			INITIAL RELEASE	01 NOV 2013

GENERAL NOTES

- 1) DO NOT SCALE THIS DRAWING
- 2) UNLESS OTHERWISE STATED:
  - a. ALL DIMENSIONING AND TOLERANCING IS IN INCHES PER ASME Y14.5-2009
  - b. BREAK ALL SHARP CORNERS AND SHARP EDGES R .010 MAXIMUM
  - c. MACHINED SURFACE FINISHES SHALL BE 125 MICROINCH OR BETTER
  - d. TAP DRILL DEPTHS SHOWN ARE MAXIMUM
  - e. FULL THREAD DEPTHS SHOWN ARE MINIMUM
  - f. CHAMFER ALL TAPED HOLES TO (NOMINAL DIA + 1/16) x 90°
- 3) FINISH:

D  
C  
B  
A

D  
C  
B  
A

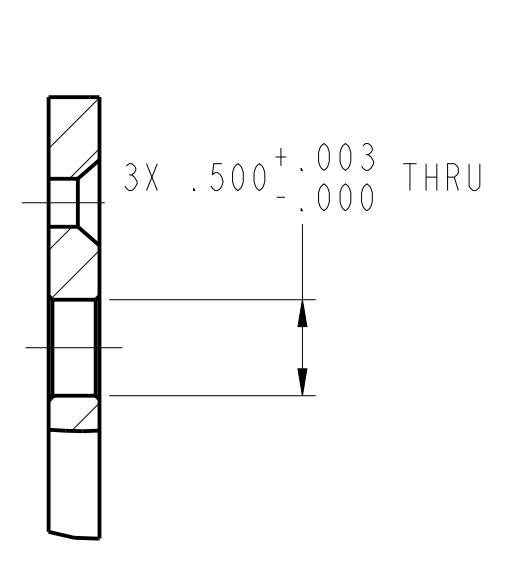

SECTION B-B

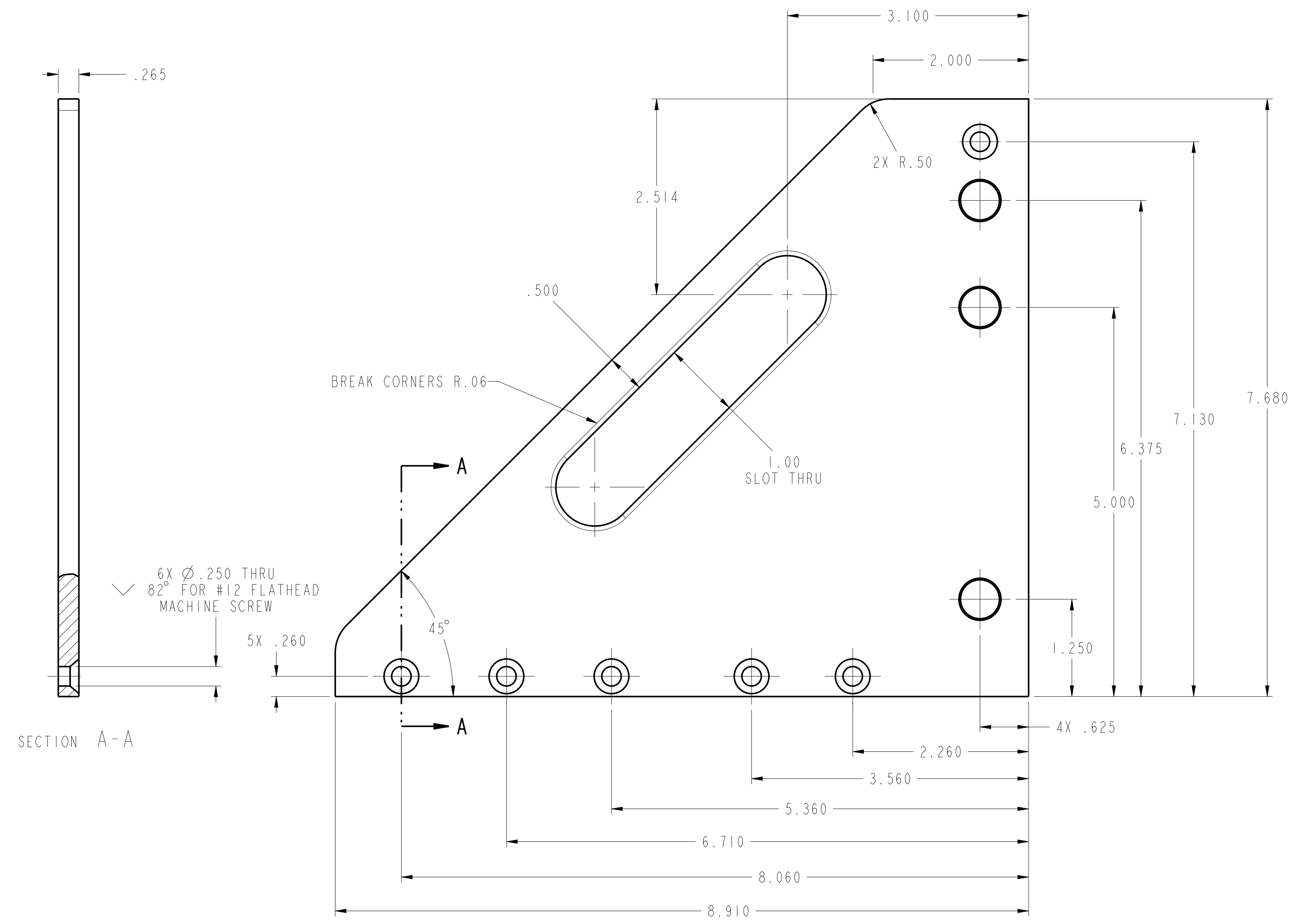

SECTION A-A

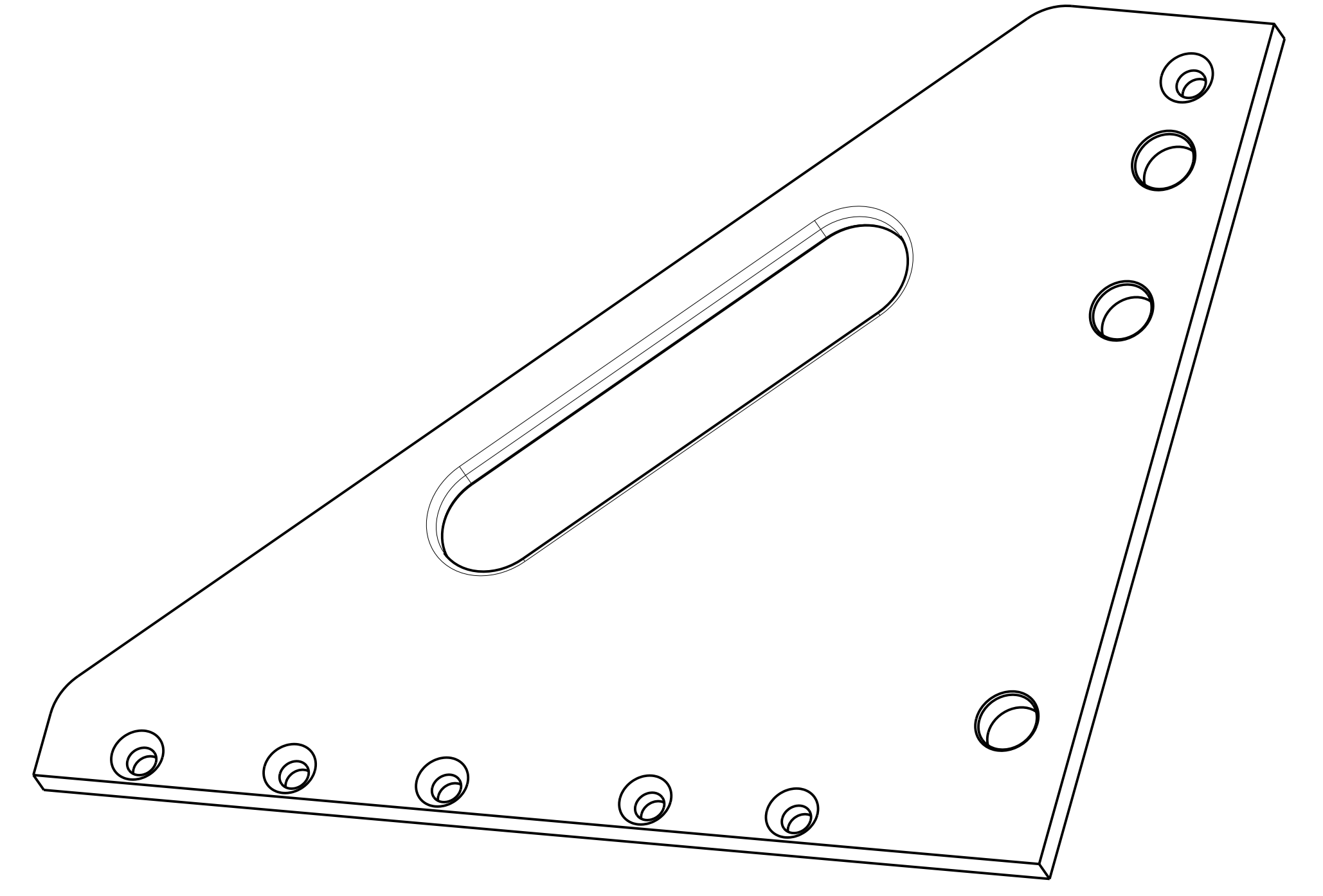

-1	CAGE	-1	SIDE PLATE	6061-T6 ALUMINUM	1
-1	PART NUMBER		DESCRIPTION	MATERIAL/SPECIFICATION/NOTES	ITEM
BILL OF MATERIAL/PARTS LIST					
DEFAULT TOLERANCES			APPROVAL SIGNATURES		
ONE PLACE (X.X) = ± 0.1	DESIGNED BY: T HUBY		<b>SOUTHWEST RESEARCH INSTITUTE</b> OFFICE of AUTOMOTIVE ENGINEERING 6220 CULEBRA ROAD SAN ANTONIO, TEXAS 78238		
TWO PLACES (X.XX) = ± 0.01	CHECKED BY: P LANG				
THREE PLACES (X.XXX) = ± 0.005	DRAWN BY: LANG/CASTANO				
FOUR PLACES (X.XXXX) = ± 0.0005	DATE: LANG/CASTANO				
ANGLES = ± 0.5 DEGREE	DATE COMPLETION: DATE:				
SURFACE FINISHES <= 125 MICROINCH RA	FILE MODEL: SIDE_PLATE_RIGHT		SCALE 1/1 UNIT WEIGHT = LBS SHEET 1 OF 1		
THIRD ANGLE PROJECTION			EXCEPT AS MAY OTHERWISE BE PROVIDED BY CONTRACT, THESE DIMENSIONS AND SPECIFICATIONS ARE THE PROPERTY OF SOUTHWEST RESEARCH INSTITUTE, ARE ISSUED IN STRICT CONFIDENCE, AND SHALL NOT BE REPRODUCED, OR COPIED, OR USED AS THE BASIS FOR MANUFACTURE OR SALE OF ANY APPARATUS SHOWN HEREON WITHOUT PERMISSION.		
		D 26401		01910-431-100-002 A	

REVISIONS				
REV	SHT	ZONE	DESCRIPTION	DATE
A			INITIAL RELEASE	01 NOV 2013

GENERAL NOTES

- 1) DO NOT SCALE THIS DRAWING
- 2) UNLESS OTHERWISE STATED:
  - a. ALL DIMENSIONING AND TOLERANCING IS IN INCHES PER ASME Y14.5-2009
  - b. BREAK ALL SHARP CORNERS AND SHARP EDGES R .010 MAXIMUM
  - c. MACHINED SURFACE FINISHES SHALL BE 125 MICROINCH OR BETTER
  - d. TAP DRILL DEPTHS SHOWN ARE MAXIMUM
  - e. FULL THREAD DEPTHS SHOWN ARE MINIMUM
  - f. CHAMFER ALL TAPED HOLES TO (NOMINAL DIA + 1/16) x 90°
- 3) FINISH:

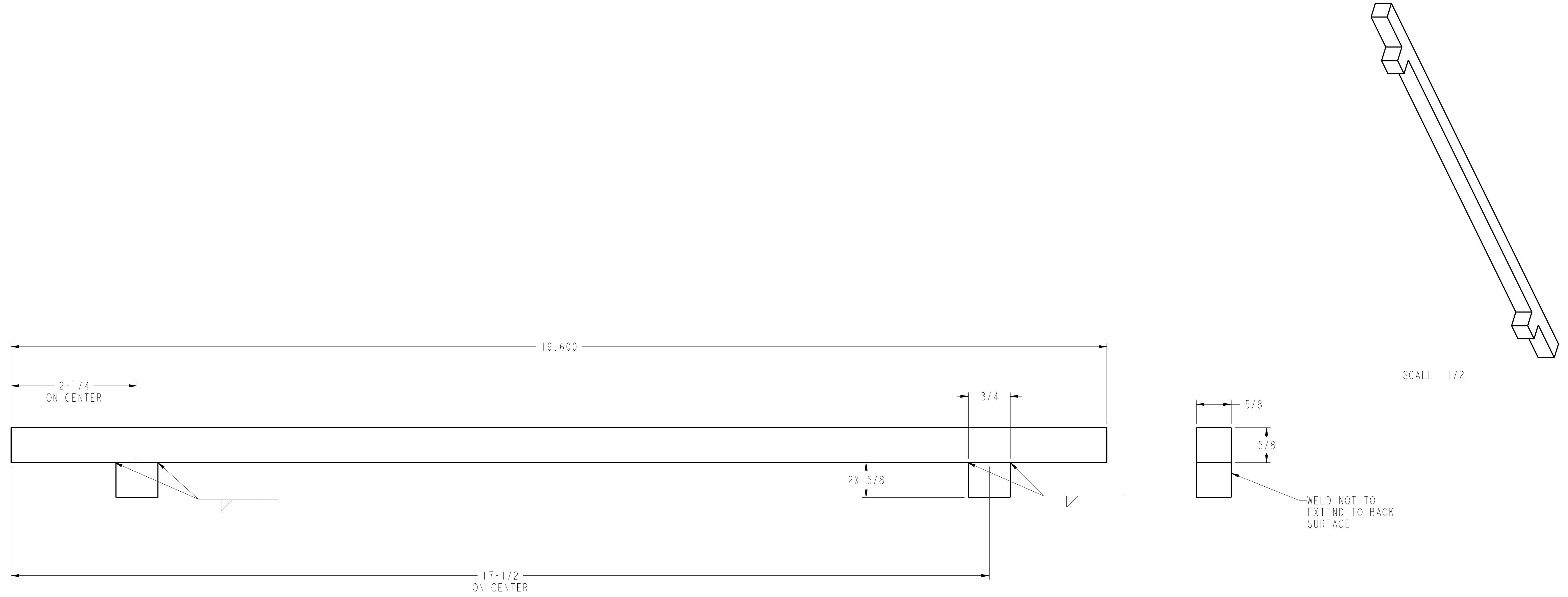

-1	CAGE	-1	SPACER BAR	6061-T6 ALUMINUM	1
-1	CAGE	PART NUMBER	DESCRIPTION	MATERIAL/SPECIFICATION/NOTES	ITEM
BILL OF MATERIAL/PARTS LIST					
DEFAULT TOLERANCES			APPROVAL SIGNATURES		
ONE PLACE (X.X) = ± 0.1	PART HBY		<p><b>SOUTHWEST RESEARCH INSTITUTE</b> OFFICE of AUTOMOTIVE ENGINEERING 6220 CULEBRA ROAD SAN ANTONIO, TEXAS 78238</p> <p><b>SIDE PLATE SPACER BAR</b></p>		
TWO PLACES (X.XX) = ± 0.01	CWD P LANG				
THREE PLACES (X.XXX) = ± 0.005	DSD LANG/CASTANO				
FOUR PLACES (X.XXXX) = ± 0.0005	PRL LANG/CASTANO				
ANGLES = ± 0.5 DEGREE	DATE COMPLETION DATE:				
SURFACE FINISHES <= 125 MICROINCH RA	FILE MODEL: SIDE_PLATE_CROSS_BAR		SCALE 1/1 UNIT WEIGHT = LBS SHEET 1 OF 1		
THIRD ANGLE PROJECTION			EXCEPT AS MAY OTHERWISE BE PROVIDED BY CONTRACT, THESE DRAWINGS AND SPECIFICATIONS ARE THE PROPERTY OF SOUTHWEST RESEARCH INSTITUTE, ARE ISSUED IN STRICT CONFIDENCE, AND SHALL NOT BE REPRODUCED, OR COPIED, OR USED AS THE BASIS FOR MANUFACTURE OR SALE OF ANY APPARATUS SHOWN THEREON WITHOUT PERMISSION.		
		D 26401		01910-431-100-003 A	



REVISIONS				
REV	SHT	ZONE	DESCRIPTION	DATE
A			INITIAL RELEASE	01 NOV 2013

GENERAL NOTES

- 1) DO NOT SCALE THIS DRAWING
- 2) UNLESS OTHERWISE STATED:
  - a. ALL DIMENSIONING AND TOLERANCING IS IN INCHES PER ASME Y14.5-2009
  - b. BREAK ALL SHARP CORNERS AND SHARP EDGES R .010 MAXIMUM
  - c. MACHINED SURFACE FINISHES SHALL BE 125 MICROINCH OR BETTER
  - d. TAP DRILL DEPTHS SHOWN ARE MAXIMUM
  - e. FULL THREAD DEPTHS SHOWN ARE MINIMUM
  - f. CHAMFER ALL TAPED HOLES TO (NOMINAL DIA + 1/16) x 90°
- 3) FINISH:

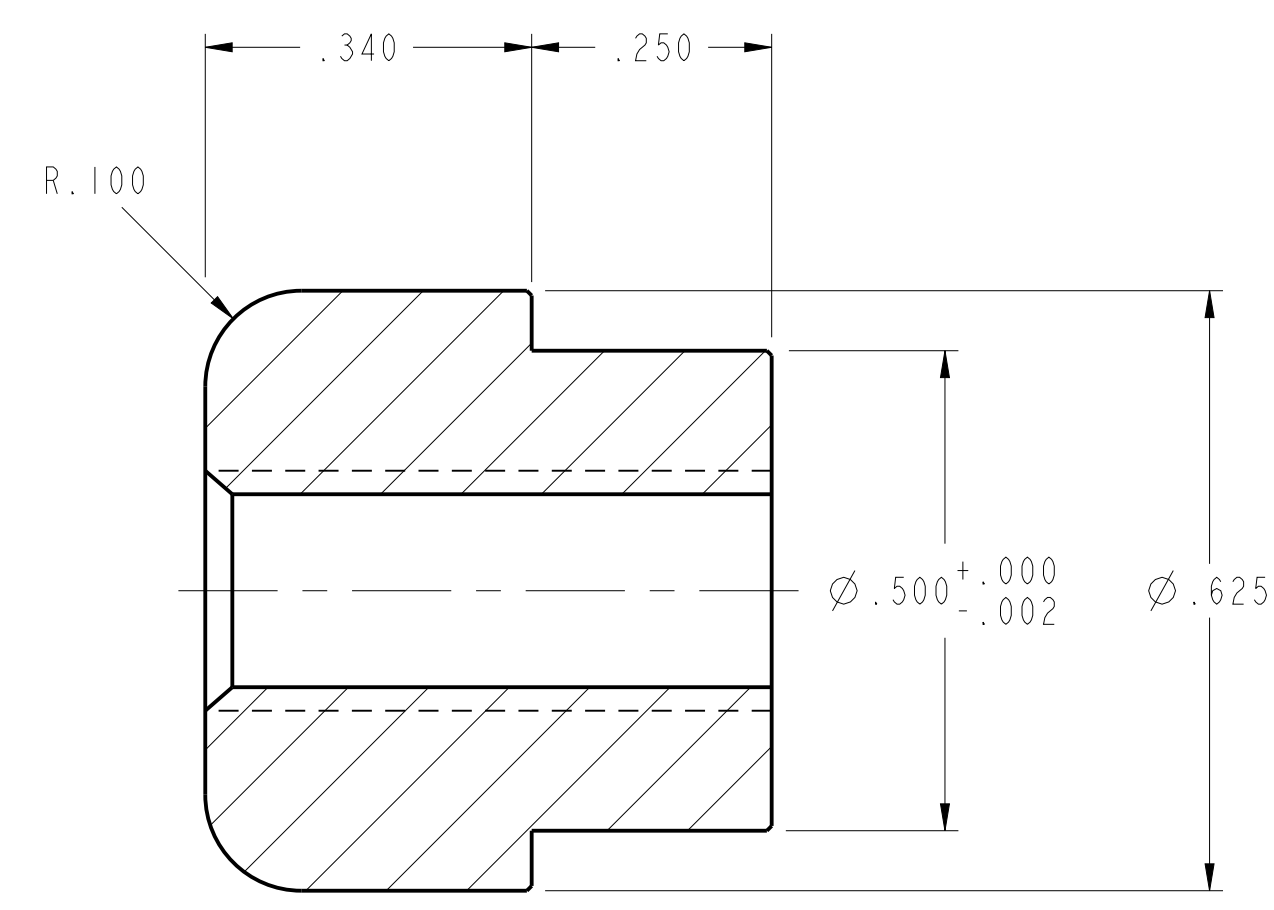
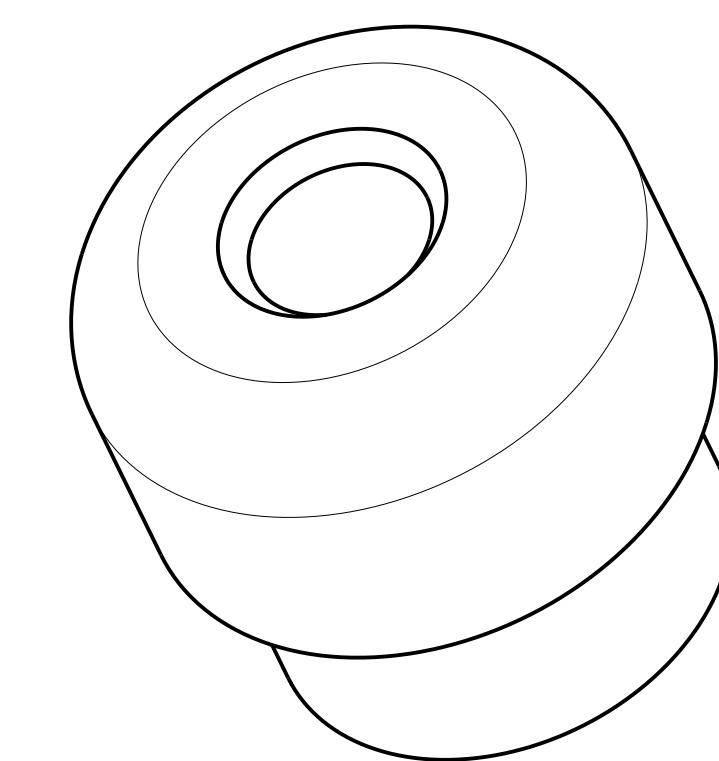

SECTION A-A

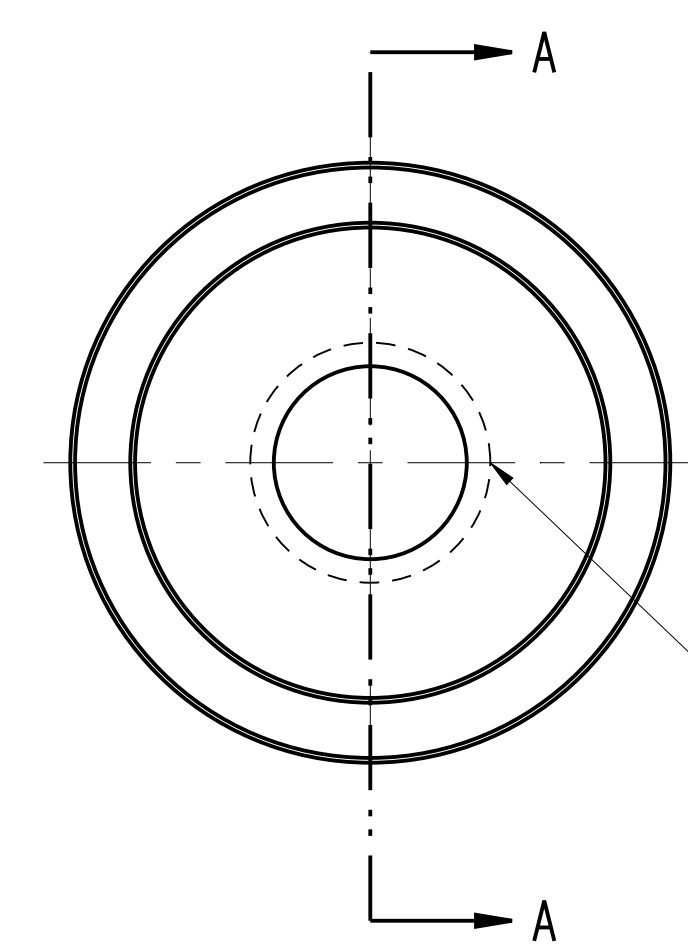

1/4-20 UNC - 2B TAP THRU  
 #7 DRILL ( 0.201 ) THRU - ( 1 ) HOLE

-1	CAGE	-1	BOSS	6061 ALUMINUM	1
-1	CAGE	PART NUMBER	DESCRIPTION	MATERIAL/SPECIFICATION/NOTES	ITEM
BILL OF MATERIAL/PARTS LIST					
DEFAULT TOLERANCES			APPROVAL SIGNATURES		
ONE PLACE (X.X) = ± 0.1	DESIGNER		APPROVED		
TWO PLACES (X.XX) = ± 0.01	CHECKER		DATE		
THREE PLACES (X.XXX) = ± 0.005	DRAWN		COMPLETION DATE:		
FOUR PLACES (X.XXXX) = ± 0.0005	FILED		MODEL: SIDE_PLATE_SCREW_BOSS		
ANGLES = ± 0.5 DEGREE	DATE		THIRD ANGLE PROJECTION		
SURFACE FINISHES <= 125 MICROINCH RA	FILE		EXCEPT AS MAY OTHERWISE BE PROVIDED BY CONTRACT, THESE DRAWINGS AND SPECIFICATIONS ARE THE PROPERTY OF SOUTHWEST RESEARCH INSTITUTE, ARE ISSUED IN STRICT CONFIDENCE, AND SHALL NOT BE REPRODUCED, OR COPIED, OR USED AS THE BASIS FOR MANUFACTURE OR SALE OF ANY APPARATUS SHOWN THEREON WITHOUT PERMISSION.		
SCALE 5/1		UNIT WEIGHT = LBS		SHEET 1 OF 1	

**SOUTHWEST RESEARCH INSTITUTE**  
 OFFICE of AUTOMOTIVE ENGINEERING  
 6220 CULEBRA ROAD SAN ANTONIO, TEXAS 78238

SIDE PLATE WELDMENT BOSS

REV D 26401 01910-431-100-004 A

REVISIONS				
REV	SHT	ZONE	DESCRIPTION	DATE
A			INITIAL RELEASE	01 NOV 2013

GENERAL NOTES

- 1) DO NOT SCALE THIS DRAWING
- 2) UNLESS OTHERWISE STATED:
  - a. ALL DIMENSIONING AND TOLERANCING IS IN INCHES PER ASME Y14.5-2009
  - b. BREAK ALL SHARP CORNERS AND SHARP EDGES R .010 MAXIMUM
  - c. MACHINED SURFACE FINISHES SHALL BE 125 MICROINCH OR BETTER
  - d. TAP DRILL DEPTHS SHOWN ARE MAXIMUM
  - e. FULL THREAD DEPTHS SHOWN ARE MINIMUM
  - f. CHAMFER ALL TAPED HOLES TO (NOMINAL DIA + 1/16) x 90°
- 3) FINISH:

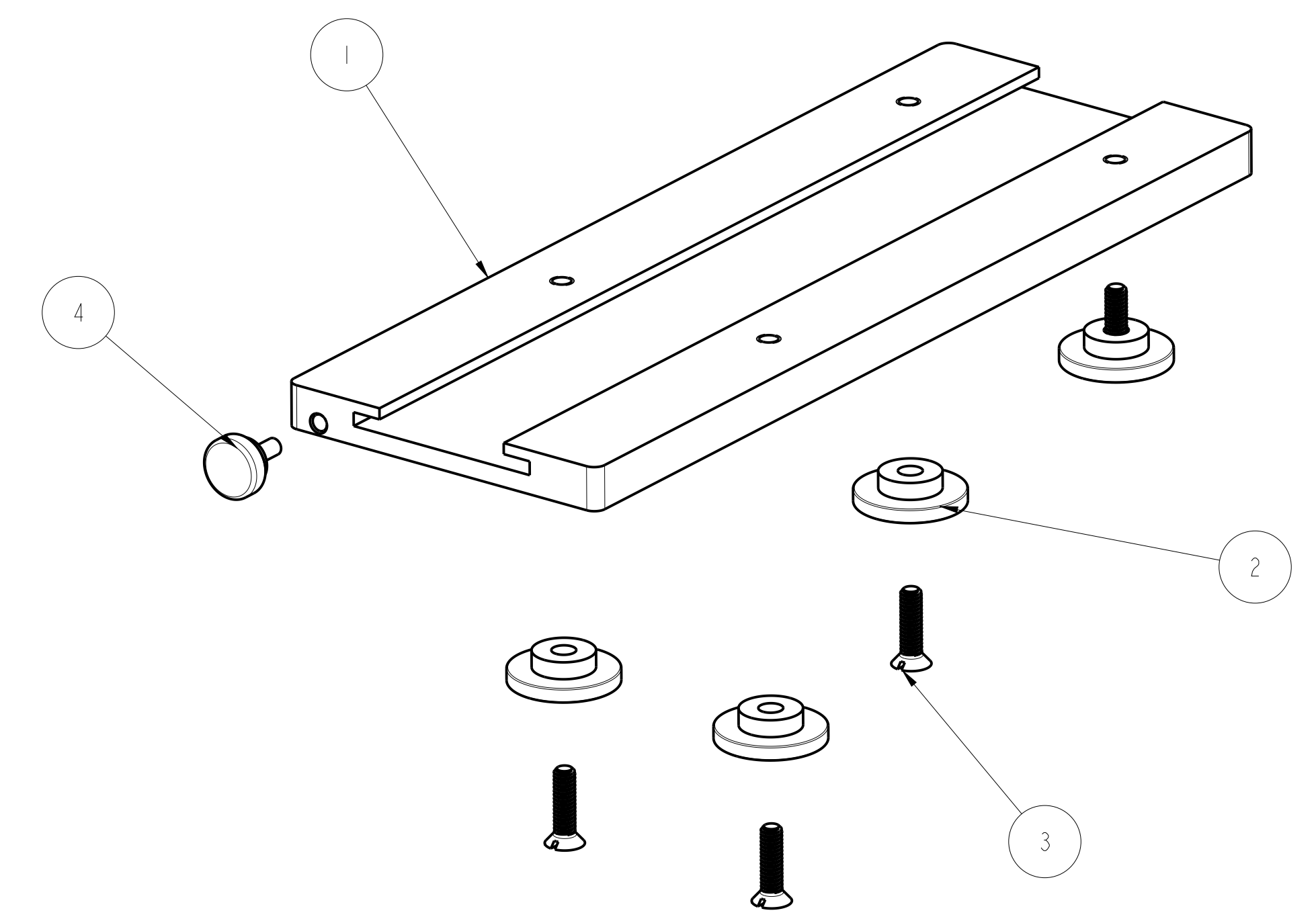
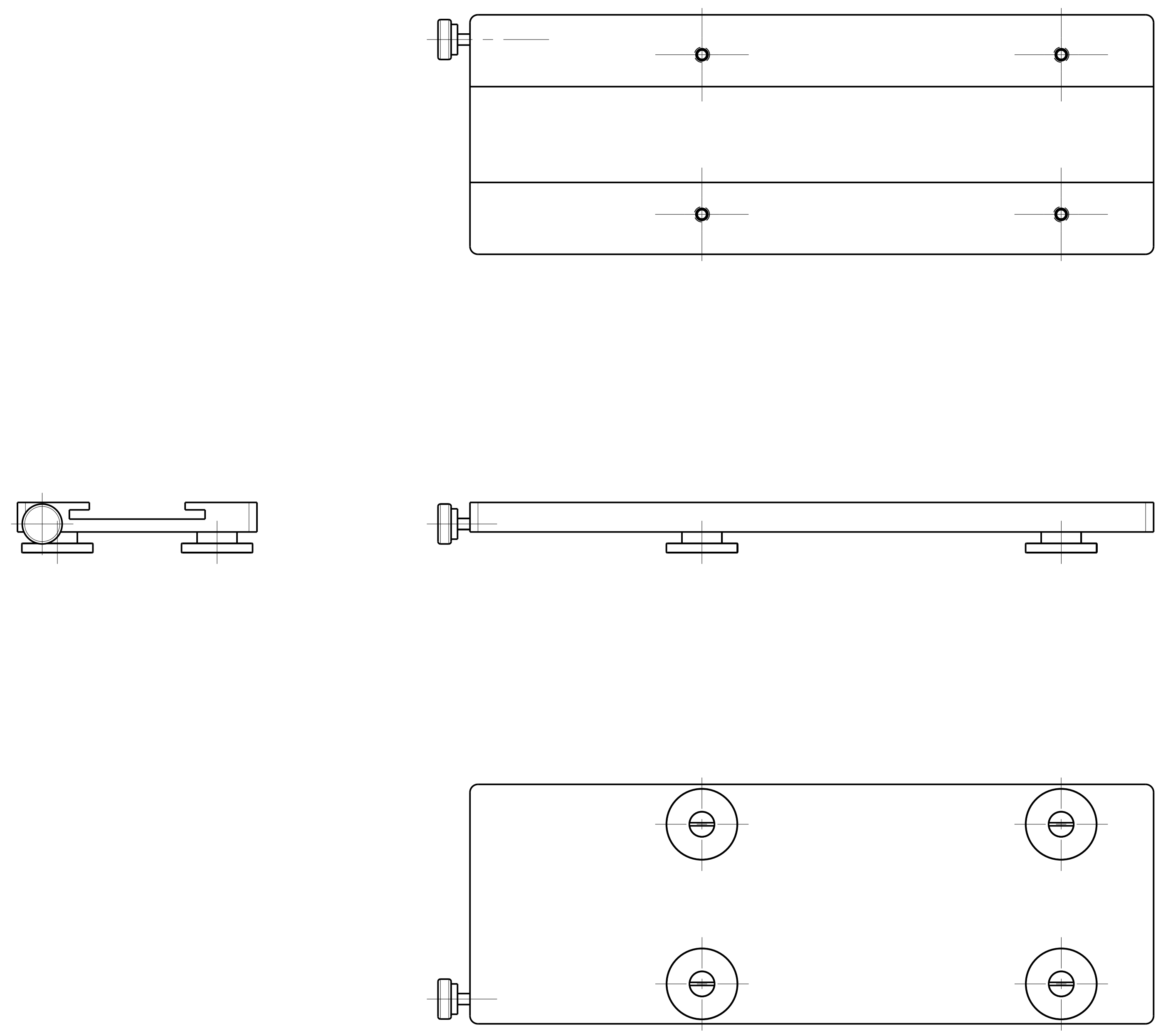

QTY	CAGE	PART NUMBER	DESCRIPTION	MATERIAL/SPECIFICATION/NOTES	ITEM
1			6-32 THREADED KNOB		4
4			8-32 X 5/8 FLAT HEAD SCREW		3
4		01910-431-200-002	SLIDE DISC		2
1		01910-431-200-001	SLIDE CRADLE		1

DEFAULT TOLERANCES ONE PLACE (X.X) = ± 0.1 TWO PLACES (X.XX) = ± 0.01 THREE PLACES (X.XXX) = ± 0.005 FOUR PLACES (X.XXXX) = ± 0.0005 ANGLES = ± 0.5 DEGREE SURFACE FINISHES <= 125 MICROINCH RA		APPROVAL SIGNATURES DESIGNED BY: P. LANG DRAWN BY: P. LANG/CASTANO DATE COMPLETION: [ ] FILE MODEL: ANALYZER_CRADLE		<b>SOUTHWEST RESEARCH INSTITUTE</b> OFFICE of AUTOMOTIVE ENGINEERING 6220 CULEBRA ROAD SAN ANTONIO, TEXAS 78238 <b>ANALYZER SLIDE CRADLE</b>	
THIRD ANGLE PROJECTION 		EXCEPT AS MAY OTHERWISE BE PROVIDED BY CONTRACT, THESE DRAWINGS AND SPECIFICATIONS ARE THE PROPERTY OF SOUTHWEST RESEARCH INSTITUTE, ARE ISSUED IN STRICT CONFIDENCE, AND SHALL NOT BE REPRODUCED, OR COPIED, OR USED AS THE BASIS FOR MANUFACTURE OR SALE OF ANY APPARATUS SHOWN HEREON WITHOUT PERMISSION.		SCALE 1/1 UNIT WEIGHT = LBS SHEET 1 OF 1	

D  
C  
B  
A

D  
C  
B  
A

REVISIONS				
REV	SHT	ZONE	DESCRIPTION	DATE
A			INITIAL RELEASE	01 NOV 2013

GENERAL NOTES

- 1) DO NOT SCALE THIS DRAWING
- 2) UNLESS OTHERWISE STATED:
  - a. ALL DIMENSIONING AND TOLERANCING IS IN INCHES PER ASME Y14.5-2009
  - b. BREAK ALL SHARP CORNERS AND SHARP EDGES R .010 MAXIMUM
  - c. MACHINED SURFACE FINISHES SHALL BE 125 MICROINCH OR BETTER
  - d. TAP DRILL DEPTHS SHOWN ARE MAXIMUM
  - e. FULL THREAD DEPTHS SHOWN ARE MINIMUM
  - f. CHAMFER ALL TAPED HOLES TO (NOMINAL DIA + 1/16) x 90°
- 3) FINISH:

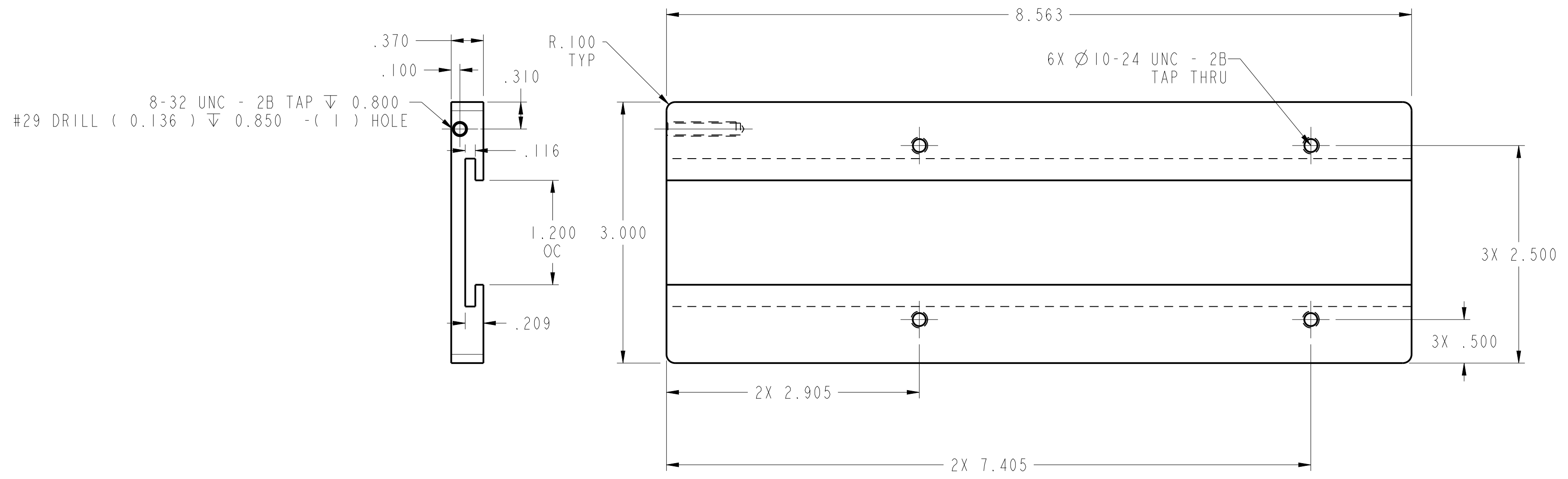
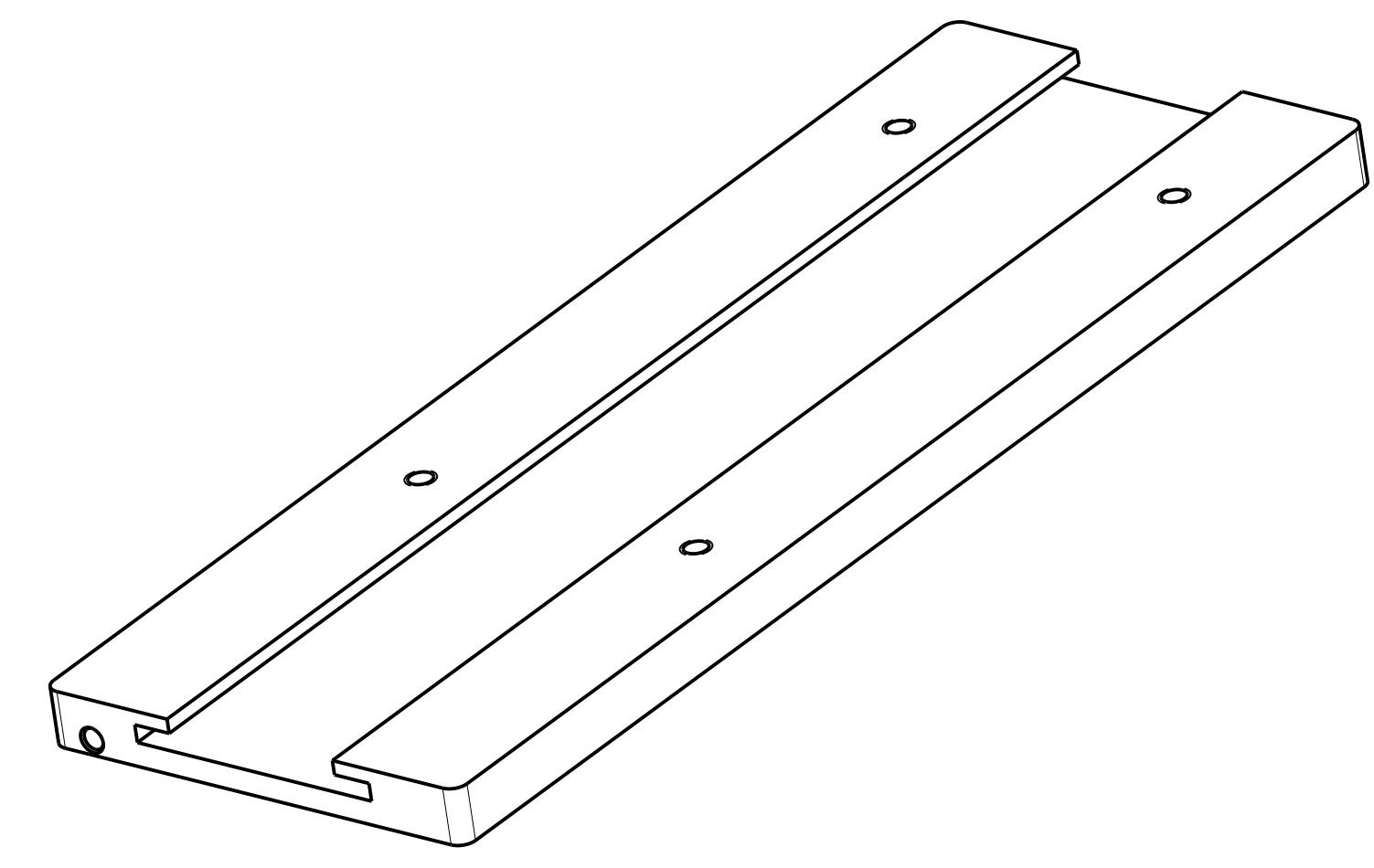

-1	CAGE	-1	CRADLE	6061-T6 ALUMINUM	1
-1	PART NUMBER		DESCRIPTION	MATERIAL/SPECIFICATION/NOTES	ITEM
BILL OF MATERIAL/PARTS LIST					
DEFAULT TOLERANCES			APPROVAL SIGNATURES		
ONE PLACE (X.X) = ± 0.1	DESIGNED BY: P. LANG		APPROVED BY: P. LANG		
TWO PLACES (X.XX) = ± 0.01	DRAWN BY: LANG/CASTANO		DATE: 11/01/2013		
THREE PLACES (X.XXX) = ± 0.005	CHECKED BY: LANG/CASTANO		COMPLETION DATE:		
FOUR PLACES (X.XXXX) = ± 0.0005	DATE: 11/01/2013		MODEL: SLIDE-CRADLE		
ANGLES = ± 0.5 DEGREE	DATE: 11/01/2013		FILE: SLIDE-CRADLE		
SURFACE FINISHES <= 125 MICROINCH RA	DATE: 11/01/2013		FILE: SLIDE-CRADLE		
THIRD ANGLE PROJECTION			EXCEPT AS MAY OTHERWISE BE PROVIDED BY CONTRACT, THESE DIMENSIONS AND SPECIFICATIONS ARE THE PROPERTY OF SOUTHWEST RESEARCH INSTITUTE, ARE ISSUED IN STRICT CONFIDENCE, AND SHALL NOT BE REPRODUCED, OR COPIED, OR USED AS THE BASIS FOR MANUFACTURE OR SALE OF ANY APPARATUS SHOWN HEREON WITHOUT PERMISSION.		
SCALE 1/1		UNIT WEIGHT = LBS		SHEET 1 OF 1	

**SOUTHWEST RESEARCH INSTITUTE**  
OFFICE of AUTOMOTIVE ENGINEERING  
6220 CULEBRA ROAD SAN ANTONIO, TEXAS 78238

**ANALYZER SLIDE CRADLE**

REV D 26401 01910-431-200-001 A

REVISIONS				
REV	SHT	ZONE	DESCRIPTION	DATE
A			INITIAL RELEASE	01 NOV 2013

GENERAL NOTES

- 1) DO NOT SCALE THIS DRAWING
- 2) UNLESS OTHERWISE STATED:
  - a. ALL DIMENSIONING AND TOLERANCING IS IN INCHES PER ASME Y14.5-2009
  - b. BREAK ALL SHARP CORNERS AND SHARP EDGES R .010 MAXIMUM
  - c. MACHINED SURFACE FINISHES SHALL BE 125 MICROINCH OR BETTER
  - d. TAP DRILL DEPTHS SHOWN ARE MAXIMUM
  - e. FULL THREAD DEPTHS SHOWN ARE MINIMUM
  - f. CHAMFER ALL TAPED HOLES TO (NOMINAL DIA + 1/16) x 90°
- 3) FINISH:

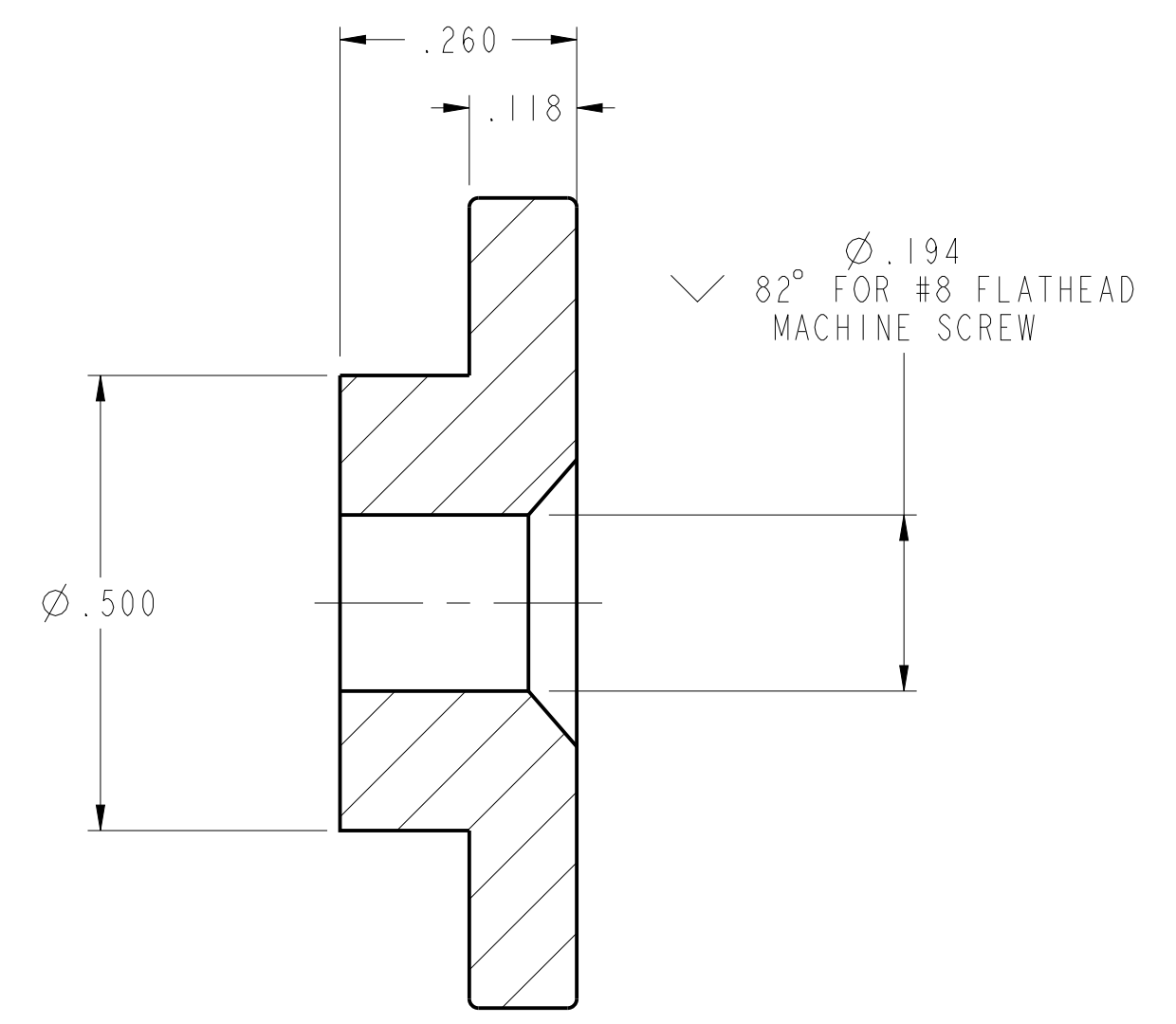
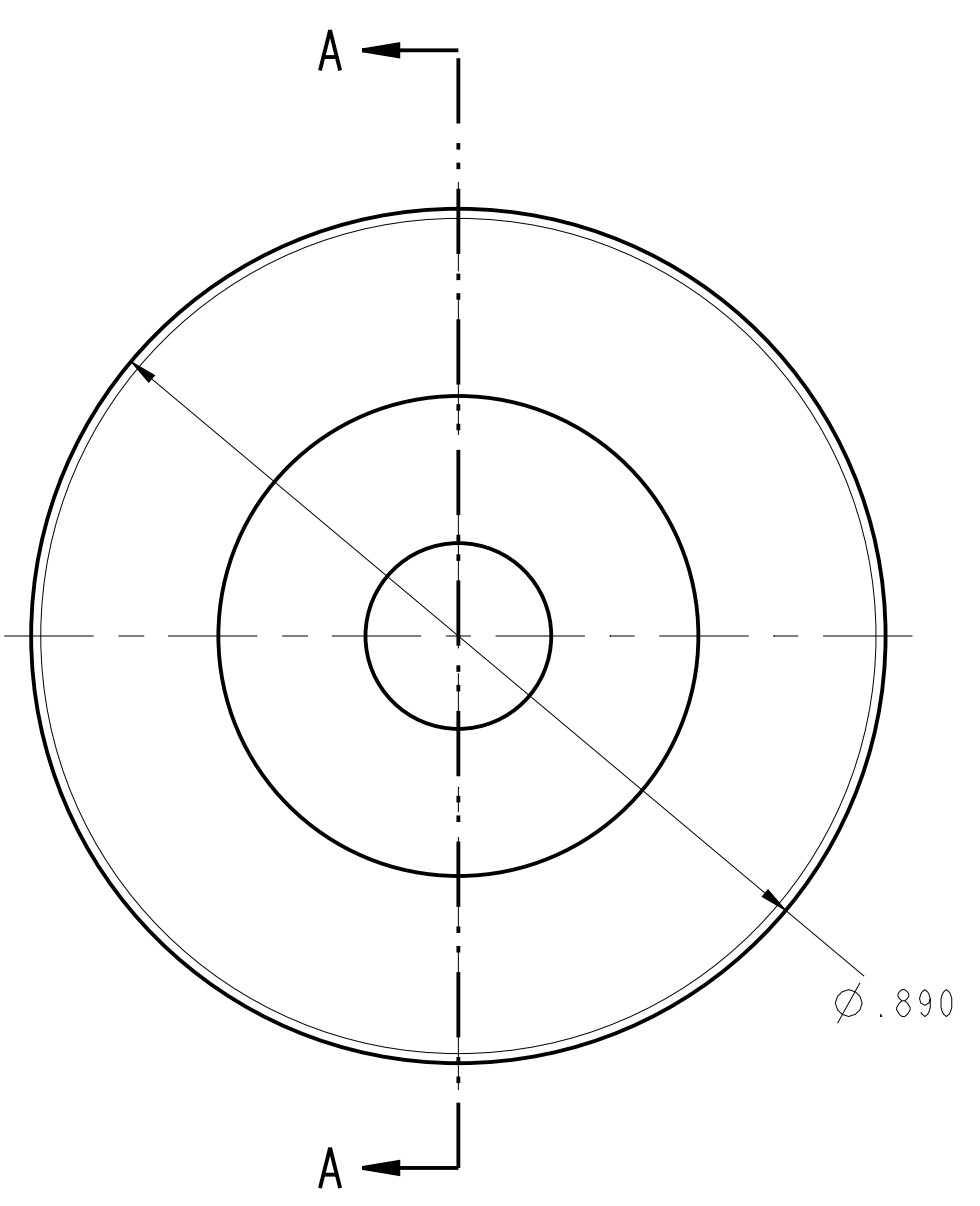

SECTION A-A

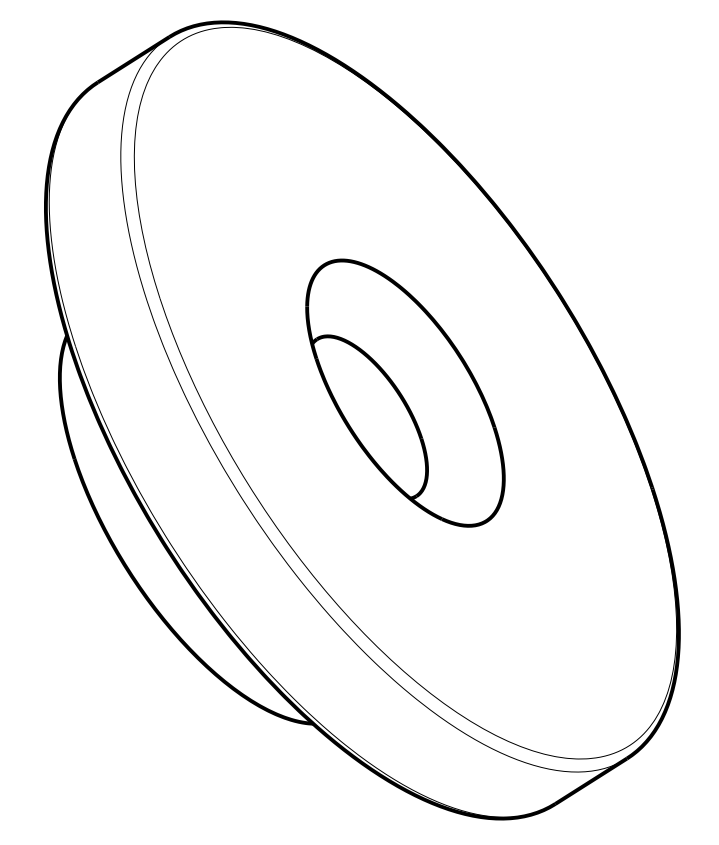

-1	CAGE	-1	SLIDE DISC	NYLON	1
-1	PART NUMBER		DESCRIPTION	MATERIAL/SPECIFICATION/NOTES	ITEM
BILL OF MATERIAL/PARTS LIST					
DEFAULT TOLERANCES			APPROVAL SIGNATURES		
ONE PLACE (X.X) = ± 0.1	DESIGNED BY: T HUBY		<b>SOUTHWEST RESEARCH INSTITUTE</b> OFFICE of AUTOMOTIVE ENGINEERING 6220 CULEBRA ROAD SAN ANTONIO, TEXAS 78238		
TWO PLACES (X.XX) = ± 0.01	CHECKED BY: P LANG				
THREE PLACES (X.XXX) = ± 0.005	DESIGNED BY: LANG/CASTANO				
FOUR PLACES (X.XXXX) = ± 0.0005	DESIGNED BY: LANG/CASTANO				
ANGLES = ± 0.5 DEGREE	DATE COMPLETION DATE:		CRADLE SLIDE TRACK DISC SCALE 5/1 UNIT WEIGHT = LBS SHEET 1 OF 1		
SURFACE FINISHES <= 125 MICROINCH RA	FILE MODEL: CRADLE_TRACK_DISC				
THIRD ANGLE PROJECTION			EXCEPT AS MAY OTHERWISE BE PROVIDED BY CONTRACT, THESE DRAWINGS AND SPECIFICATIONS ARE THE PROPERTY OF SOUTHWEST RESEARCH INSTITUTE, ARE ISSUED IN STRICT CONFIDENCE, AND SHALL NOT BE REPRODUCED, OR COPIED, OR USED AS THE BASIS FOR MANUFACTURE OR SALE OF ANY APPARATUS SHOW THEREON WITHOUT PERMISSION.		
			D 26401 01910-431-200-002 A		

REVISIONS				
REV	SHT	ZONE	DESCRIPTION	DATE
A			INITIAL RELEASE	01 NOV 2013

GENERAL NOTES

- 1) DO NOT SCALE THIS DRAWING
- 2) UNLESS OTHERWISE STATED:
  - a. ALL DIMENSIONING AND TOLERANCING IS IN INCHES PER ASME Y14.5-2009
  - b. BREAK ALL SHARP CORNERS AND SHARP EDGES R .010 MAXIMUM
  - c. MACHINED SURFACE FINISHES SHALL BE 125 MICROINCH OR BETTER
  - d. TAP DRILL DEPTHS SHOWN ARE MAXIMUM
  - e. FULL THREAD DEPTHS SHOWN ARE MINIMUM
  - f. CHAMFER ALL TAPED HOLES TO (NOMINAL DIA + 1/16) x 90°
- 3) FINISH:

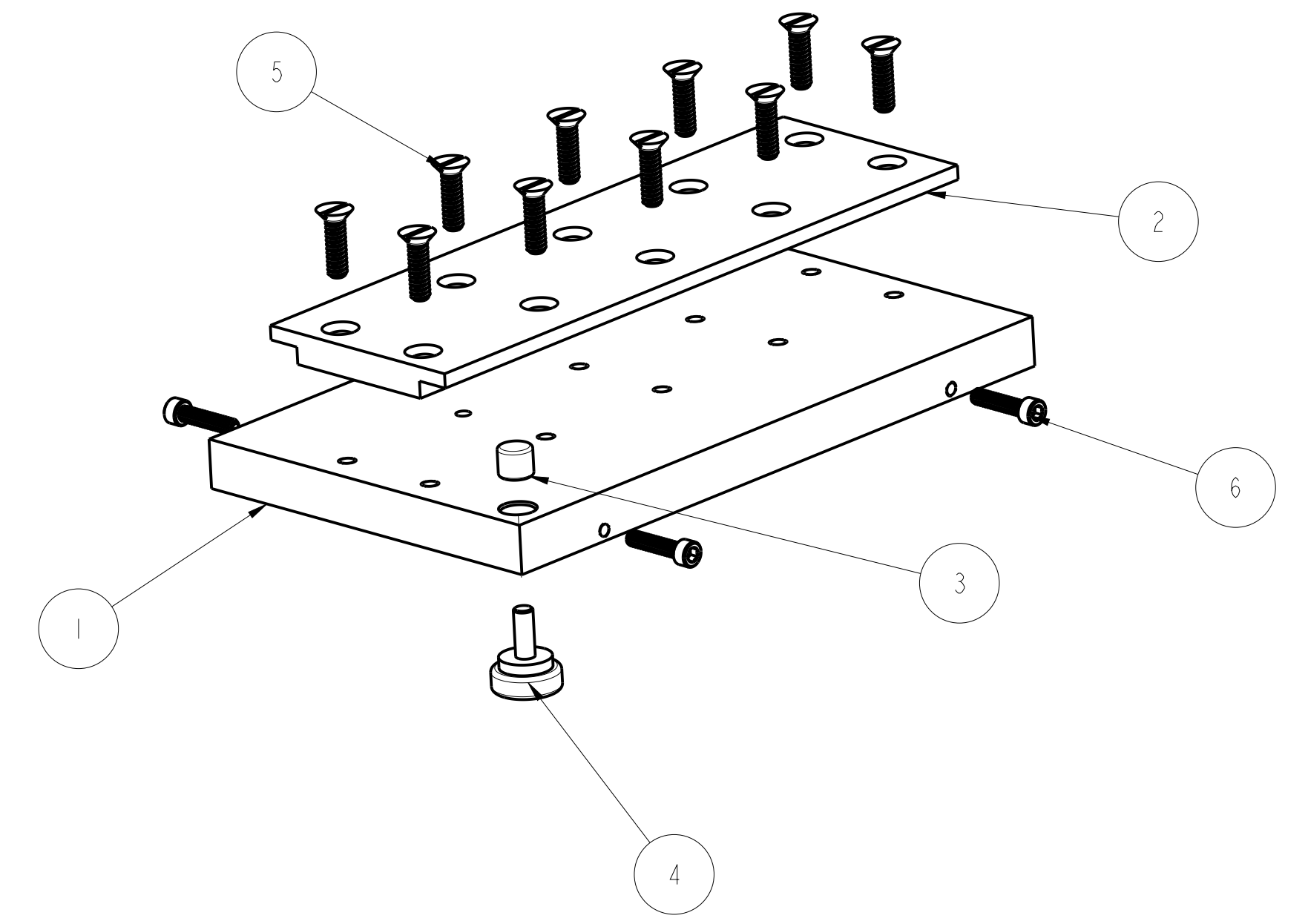
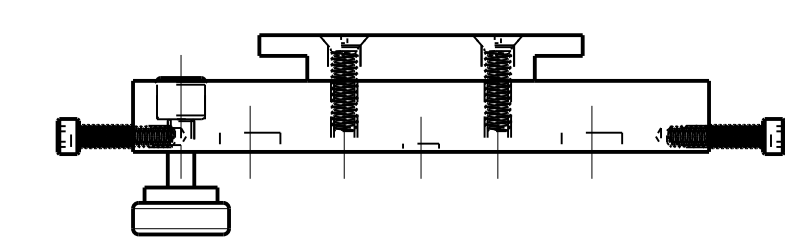
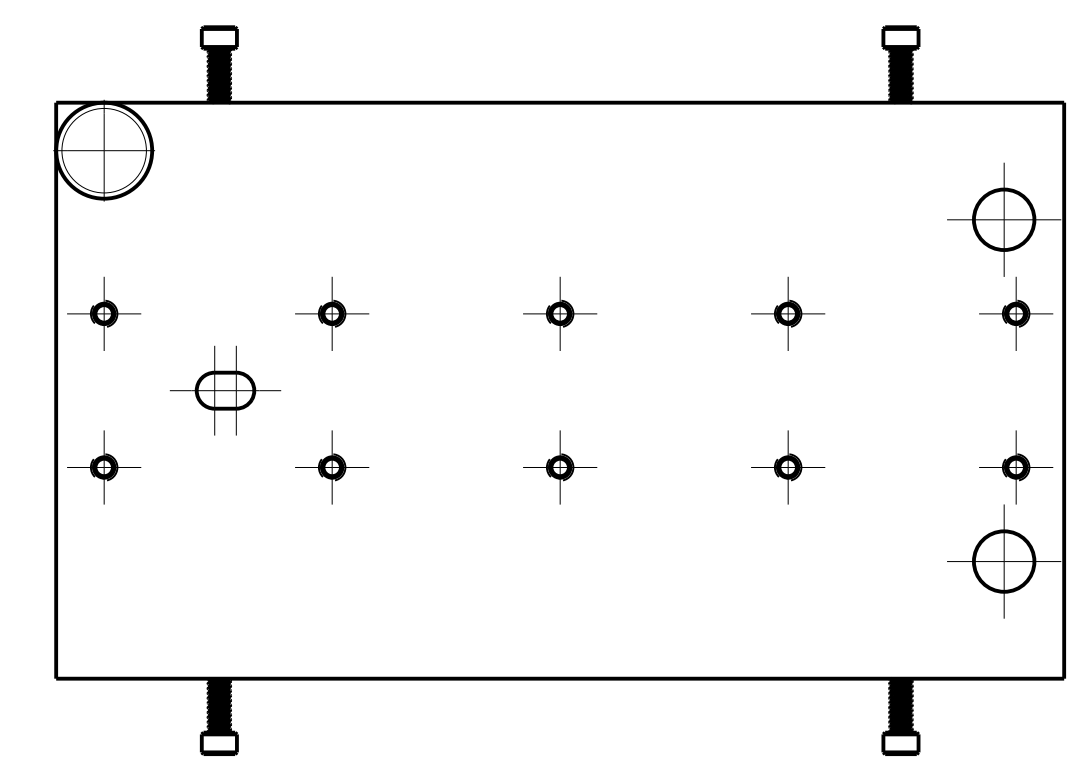
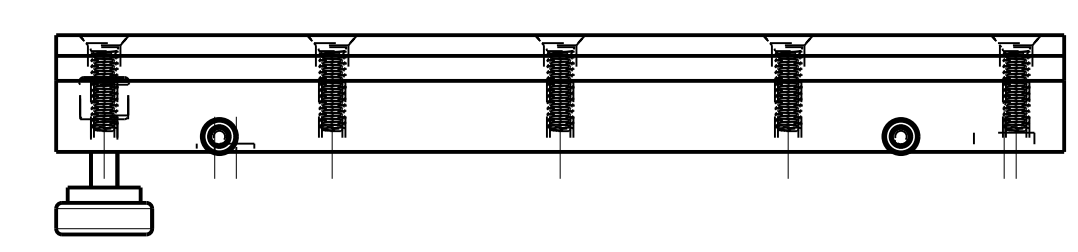
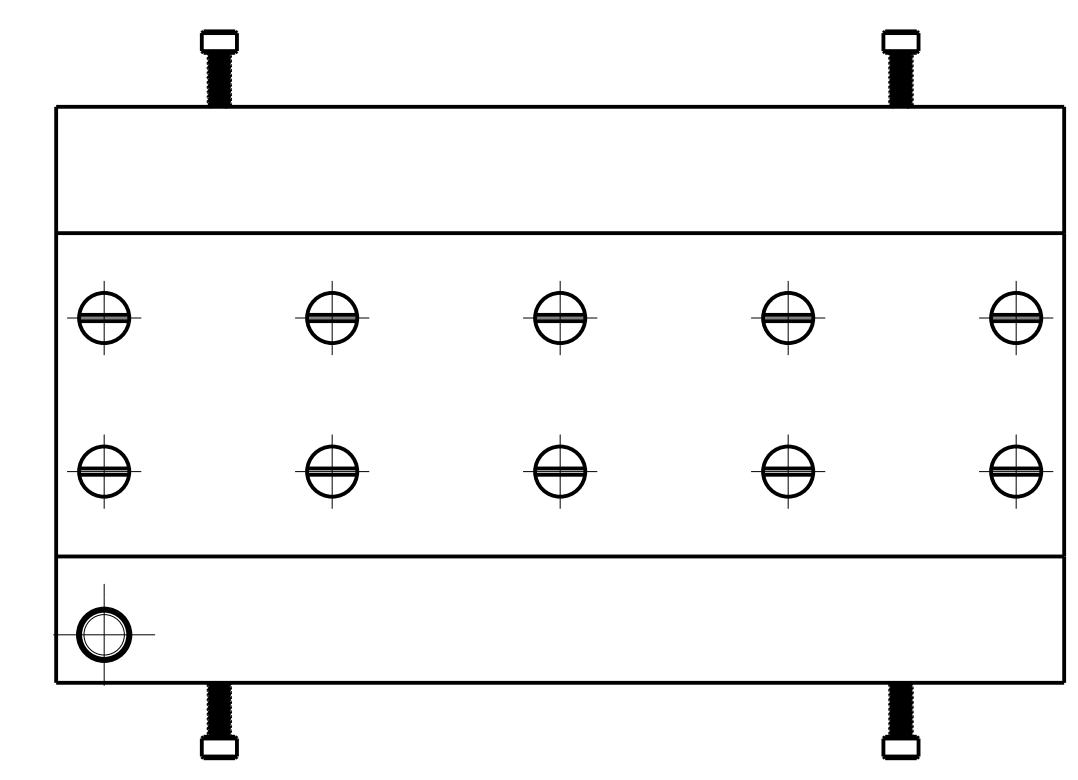

QTY	CAGE	PART NUMBER	DESCRIPTION	MATERIAL/SPECIFICATION/NOTES	ITEM
4			Ø4-40 X 1/2 SHCS		6
10			Ø6-32 X 1/2 FLAT HEAD SCREW		5
1			6-32 THREADED KNOB		4
1		01910-431-300-003	BUSHING		3
1		01910-431-300-002	SLIDE TRACK		2
1		01910-431-300-001	SLIDE MOUNT		1

DEFAULT TOLERANCES ONE PLACE (X.X) = ± 0.1 TWO PLACES (X.XX) = ± 0.01 THREE PLACES (X.XXX) = ± 0.005 FOUR PLACES (X.XXXX) = ± 0.0005 ANGLES = ± 0.5 DEGREE SURFACE FINISHES <= 125 MICROINCH RA		APPROVAL SIGNATURES DESIGNED BY: T. HABY CHECKED BY: P. LANG DRAWN BY: LANG/CASTANO DATE: LANG/CASTANO DATE COMPLETION: DATE: FILE MODEL: ANALYZER_MOUNT		<b>SOUTHWEST RESEARCH INSTITUTE</b> OFFICE of AUTOMOTIVE ENGINEERING 6220 CULEBRA ROAD SAN ANTONIO, TEXAS 78238	
THIRD ANGLE PROJECTION 		EXCEPT AS OTHERWISE PROVIDED BY CONTRACT, THESE DRAWINGS AND SPECIFICATIONS ARE THE PROPERTY OF SOUTHWEST RESEARCH INSTITUTE, ARE ISSUED IN STRICT CONFIDENCE, AND SHALL NOT BE REPRODUCED, OR COPIED, OR USED AS THE BASIS FOR MANUFACTURE OR SALE OF ANY APPARATUS SHOWN HEREON WITHOUT PERMISSION.		<b>ANALYZER MOUNT</b> SCALE 1/1 UNIT WEIGHT = LBS SHEET 1 OF 1	
PART NUMBER: <b>D 26401</b>		MODEL NUMBER: <b>01910-431-300-000</b>		REV: <b>A</b>	

REVISIONS				
REV	SHT	ZONE	DESCRIPTION	DATE
A			INITIAL RELEASE	01 NOV 2013

GENERAL NOTES

- 1) DO NOT SCALE THIS DRAWING
- 2) UNLESS OTHERWISE STATED:
  - a. ALL DIMENSIONING AND TOLERANCING IS IN INCHES PER ASME Y14.5-2009
  - b. BREAK ALL SHARP CORNERS AND SHARP EDGES R .010 MAXIMUM
  - c. MACHINED SURFACE FINISHES SHALL BE 125 MICROINCH OR BETTER
  - d. TAP DRILL DEPTHS SHOWN ARE MAXIMUM
  - e. FULL THREAD DEPTHS SHOWN ARE MINIMUM
  - f. CHAMFER ALL TAPED HOLES TO (NOMINAL DIA + 1/16) x 90°
- 3) FINISH:

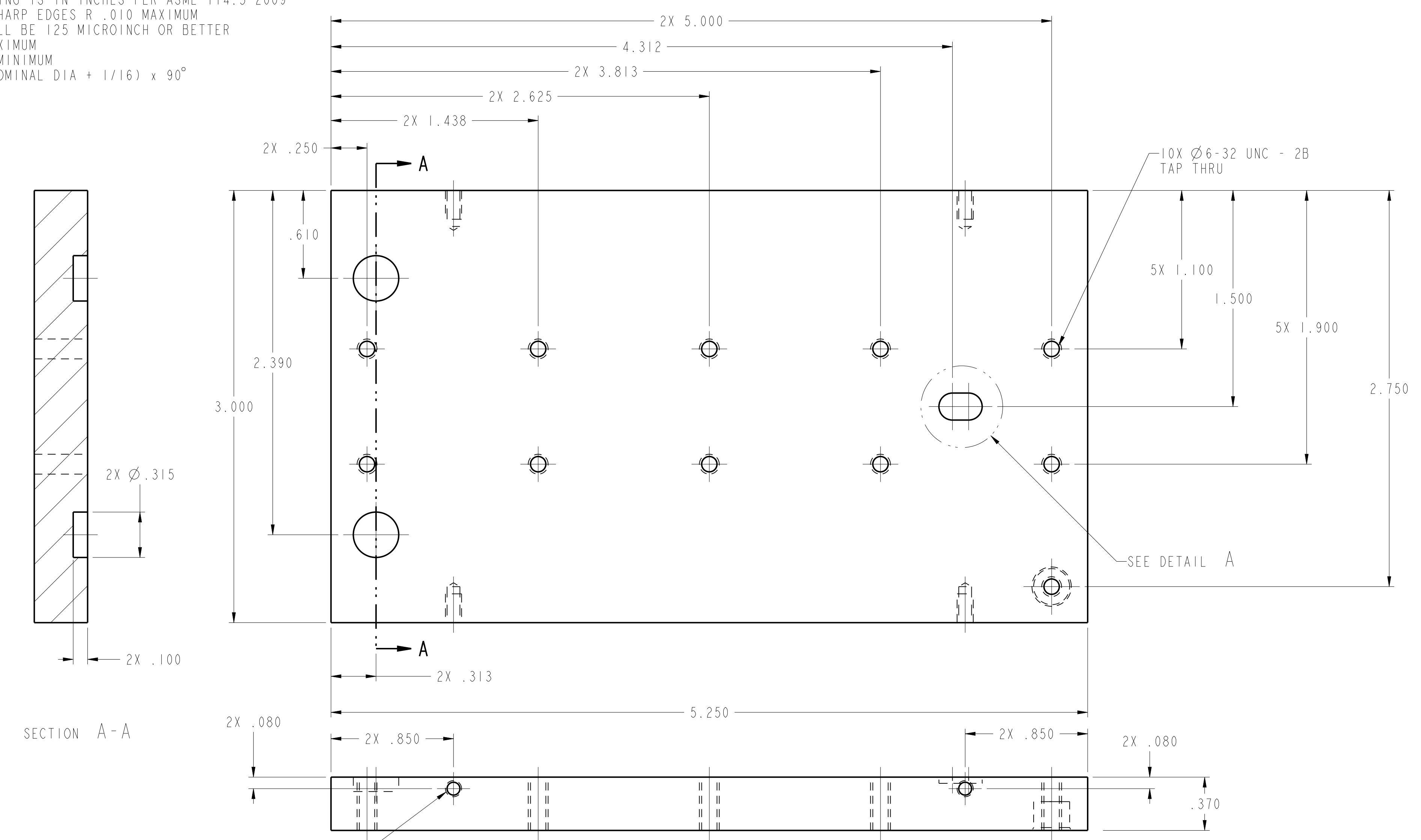

SECTION A-A

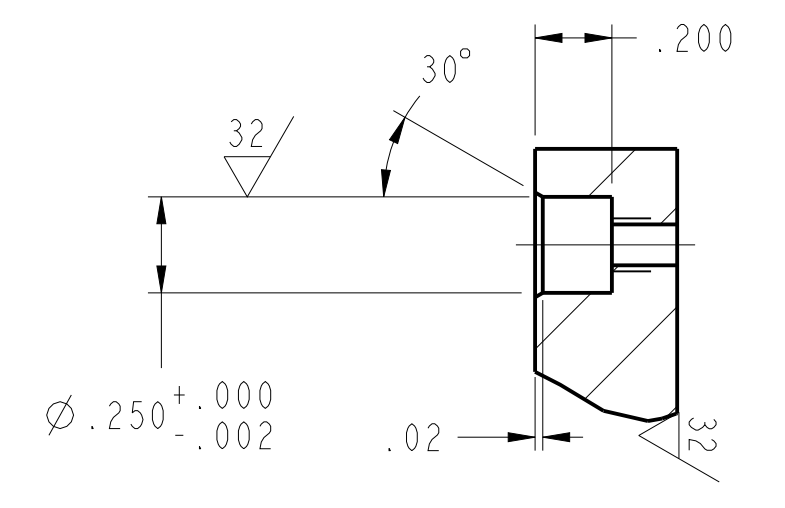

SECTION B-B

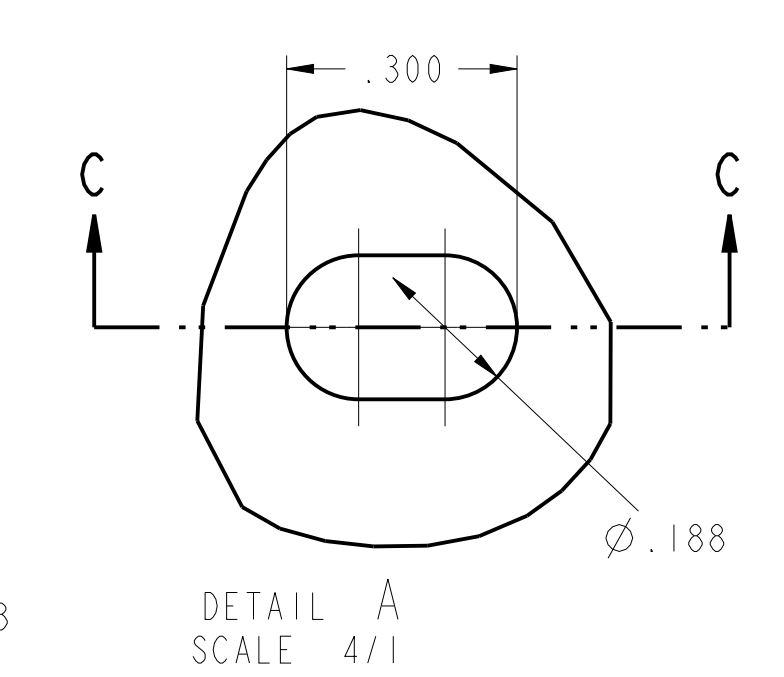

DETAIL A SCALE 4/1

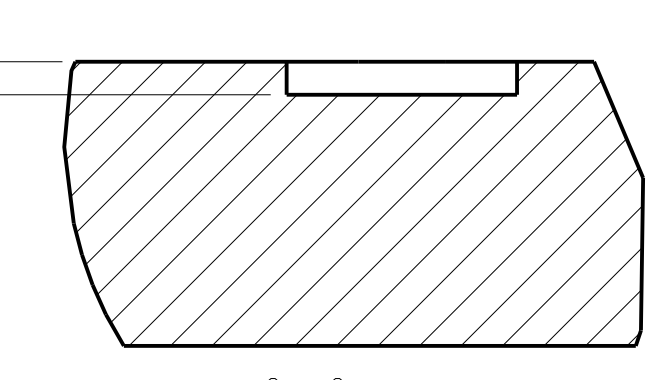

SECTION C-C

-1	-1	SLIDE MOUNT	6061-T6 ALUMINUM	1
-1	CAGE	PART NUMBER	DESCRIPTION	MATERIAL/SPECIFICATION/NOTES
BILL OF MATERIAL/PARTS LIST				
DEFAULT TOLERANCES		APPROVAL SIGNATURES		
ONE PLACE (X.X) = ± 0.1	DESIGNER	T. HABY		
TWO PLACES (X.XX) = ± 0.01	CHKD	P. LANGE		
THREE PLACES (X.XXX) = ± 0.005	APPD	LANG/CASTANO		
FOUR PLACES (X.XXXX) = ± 0.0005	DATE	LANG/CASTANO		
ANGLES = ± 0.5 DEGREE	FILE	COMPLETION DATE:		
SURFACE FINISHES <= 125 MICROINCH RA	MODEL	ANALYZER_MOUNT_BASE		
THIRD ANGLE PROJECTION		EXCEPT AS OTHERWISE PROVIDED BY CONTRACT, THESE DIMENSIONS AND SPECIFICATIONS ARE THE PROPERTY OF SOUTHWEST RESEARCH INSTITUTE, ARE ISSUED IN STRICT CONFIDENCE, AND SHALL NOT BE REPRODUCED, OR COPIED, OR USED AS THE BASIS FOR MANUFACTURE OR SALE OF ANY APPARATUS SHOWN HEREON WITHOUT PERMISSION.		
		<b>SOUTHWEST RESEARCH INSTITUTE</b> OFFICE of AUTOMOTIVE ENGINEERING 6220 CULEBRA ROAD SAN ANTONIO, TEXAS 78238		
		<b>ANALYZER SLIDE MOUNT</b>		
SHEET	26401	PROJECT NUMBER	01910-431-300-001	REV
D				A
SCALE 2/1		UNIT WEIGHT = LBS		SHEET 1 OF 1

REVISIONS				
REV	SHT	ZONE	DESCRIPTION	DATE
A			INITIAL RELEASE	01 NOV 2013

GENERAL NOTES

- 1) DO NOT SCALE THIS DRAWING
- 2) UNLESS OTHERWISE STATED:
  - a. ALL DIMENSIONING AND TOLERANCING IS IN INCHES PER ASME Y14.5-2009
  - b. BREAK ALL SHARP CORNERS AND SHARP EDGES R .010 MAXIMUM
  - c. MACHINED SURFACE FINISHES SHALL BE 125 MICROINCH OR BETTER
  - d. TAP DRILL DEPTHS SHOWN ARE MAXIMUM
  - e. FULL THREAD DEPTHS SHOWN ARE MINIMUM
  - f. CHAMFER ALL TAPED HOLES TO (NOMINAL DIA + 1/16) x 90°
- 3) FINISH:

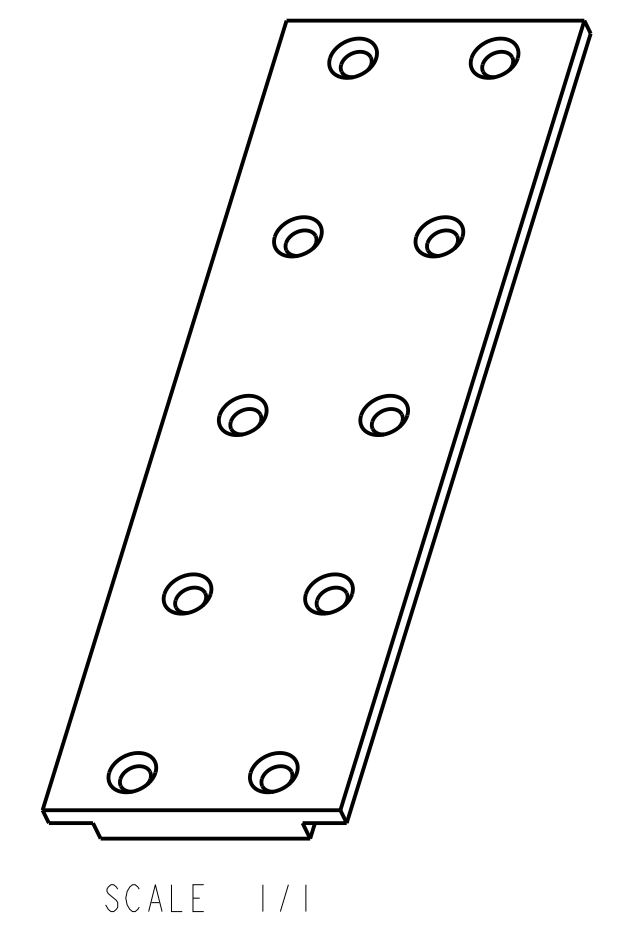
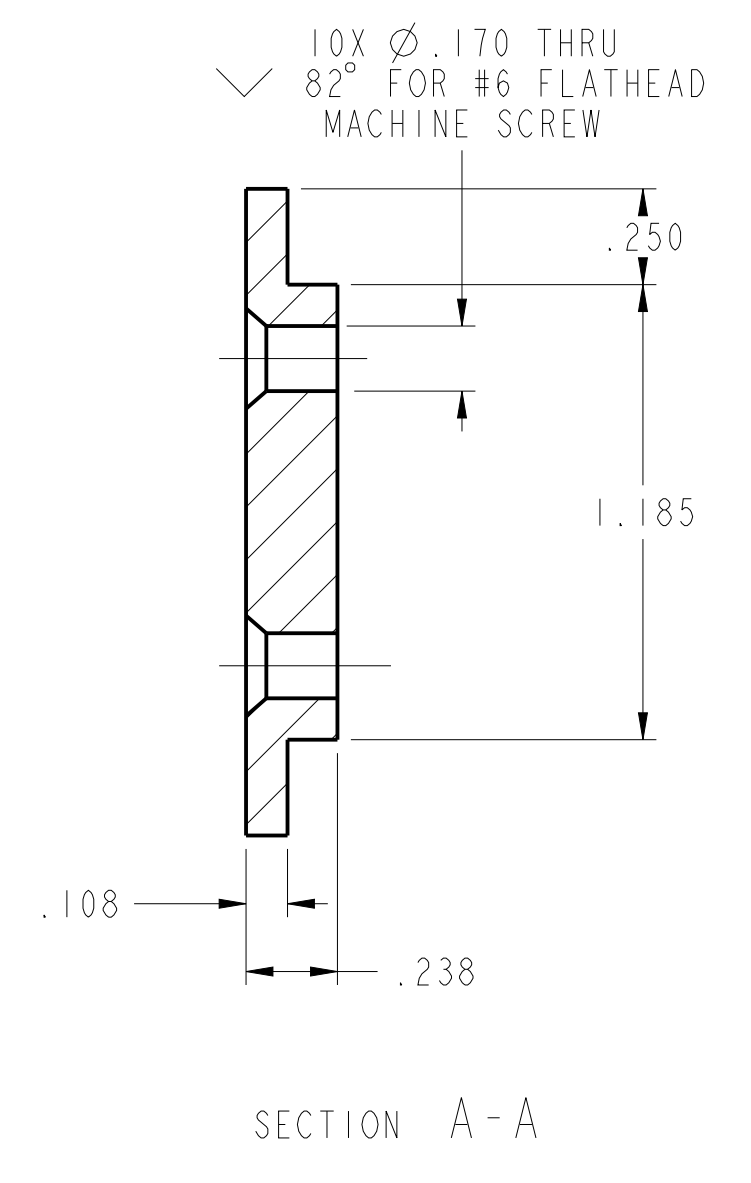
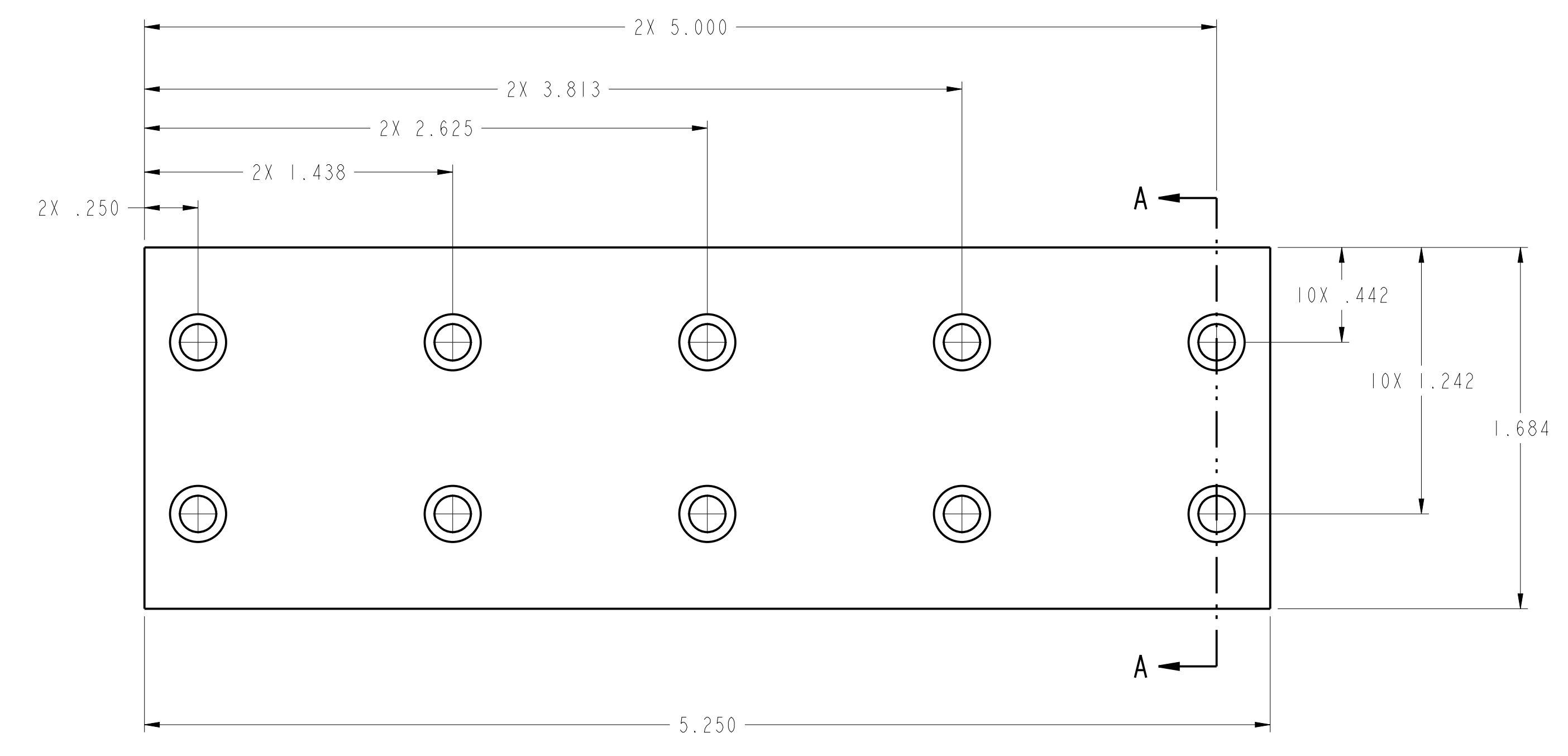

-1	CAGE	-1	SLIDE TRACK	NYLON	1
-1	PART NUMBER		DESCRIPTION	MATERIAL/SPECIFICATION/NOTES	ITEM
BILL OF MATERIAL/PARTS LIST					
DEFAULT TOLERANCES			APPROVAL SIGNATURES		
ONE PLACE (X.X) = ± 0.1	DESIGNED BY: T HADY		<b>SOUTHWEST RESEARCH INSTITUTE</b> OFFICE of AUTOMOTIVE ENGINEERING 6220 CULEBRA ROAD SAN ANTONIO, TEXAS 78238		
TWO PLACES (X.XX) = ± 0.01	CHECKED BY: P LANG				
THREE PLACES (X.XXX) = ± 0.005	DESIGNED BY: LANG/CASTANO				
FOUR PLACES (X.XXXX) = ± 0.0005	DESIGNED BY: LANG/CASTANO				
ANGLES = ± 0.5 DEGREE	DATE COMPLETION DATE:				
SURFACE FINISHES <= 125 MICROINCH RA			FILE MODEL: ANALYZER_MOUNT_SLIDE		
THIRD ANGLE PROJECTION			EXCEPT AS MAY OTHERWISE BE PROVIDED BY CONTRACT, THESE DRAWINGS AND SPECIFICATIONS ARE THE PROPERTY OF SOUTHWEST RESEARCH INSTITUTE, ARE ISSUED IN STRICT CONFIDENCE, AND SHALL NOT BE REPRODUCED, OR COPIED, OR USED AS THE BASIS FOR MANUFACTURE OR SALE OF ANY APPARATUS SHOW HEREON WITHOUT PERMISSION.		
		D 26401		01910-431-300-002 A	
			SCALE 2/1		UNIT WEIGHT = LBS
					SHEET 1 OF 1

REVISIONS				
REV	SHT	ZONE	DESCRIPTION	DATE
A			INITIAL RELEASE	01 NOV 2013

GENERAL NOTES

- 1) DO NOT SCALE THIS DRAWING
- 2) UNLESS OTHERWISE STATED:
  - a. ALL DIMENSIONING AND TOLERANCING IS IN INCHES PER ASME Y14.5-2009
  - b. BREAK ALL SHARP CORNERS AND SHARP EDGES R .010 MAXIMUM
  - c. MACHINED SURFACE FINISHES SHALL BE 125 MICROINCH OR BETTER
  - d. TAP DRILL DEPTHS SHOWN ARE MAXIMUM
  - e. FULL THREAD DEPTHS SHOWN ARE MINIMUM
  - f. CHAMFER ALL TAPED HOLES TO (NOMINAL DIA + 1/16) x 90°
- 3) FINISH:

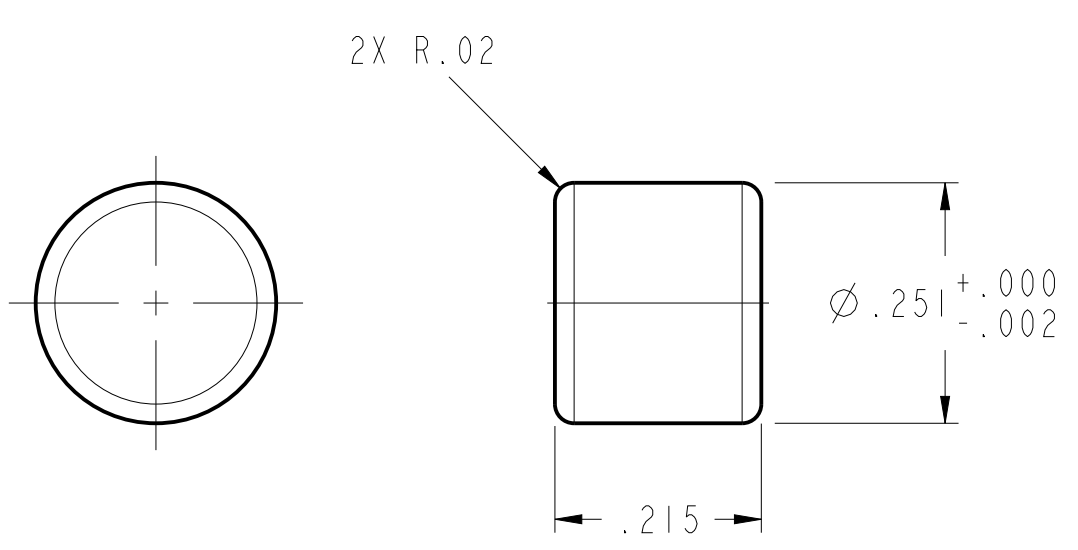
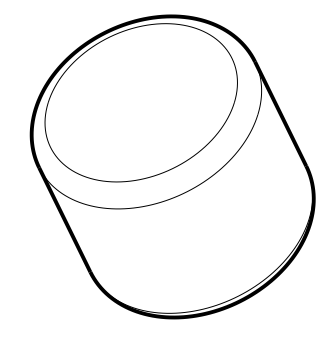

-1	CAGE	-1	BUSHING	NYLON	1
-1	CAGE	PART NUMBER	DESCRIPTION	MATERIAL/SPECIFICATION/NOTES	ITEM
BILL OF MATERIAL/PARTS LIST					
DEFAULT TOLERANCES			APPROVAL SIGNATURES		
ONE PLACE (X.X) = ± 0.1	PART HBY		<b>SOUTHWEST RESEARCH INSTITUTE</b> OFFICE of AUTOMOTIVE ENGINEERING 6220 CULEBRA ROAD SAN ANTONIO, TEXAS 78238		
TWO PLACES (X.XX) = ± 0.01	CWD P LANG				
THREE PLACES (X.XXX) = ± 0.005	DSD LANG/CASTANO				
FOUR PLACES (X.XXXX) = ± 0.0005	PRL LANG/CASTANO				
ANGLES = ± 0.5 DEGREE	DATE COMPLETION DATE:				
SURFACE FINISHES <= 125 MICROINCH RA	FILE MODEL: ANALYZER_CRADLE_BRAKE		EXCEPT AS MAY OTHERWISE BE PROVIDED BY CONTRACT, THESE DRAWINGS AND SPECIFICATIONS ARE THE PROPERTY OF SOUTHWEST RESEARCH INSTITUTE, ARE ISSUED IN STRICT CONFIDENCE, AND SHALL NOT BE REPRODUCED, OR COPIED, OR USED AS THE BASIS FOR MANUFACTURE OR SALE OF ANY APPARATUS SHOWN HEREON WITHOUT PERMISSION.		
THIRD ANGLE PROJECTION					
D 26401		01910-431-300-003		A	
SCALE 5/1		UNIT WEIGHT = LBS		SHEET 1 OF 1	



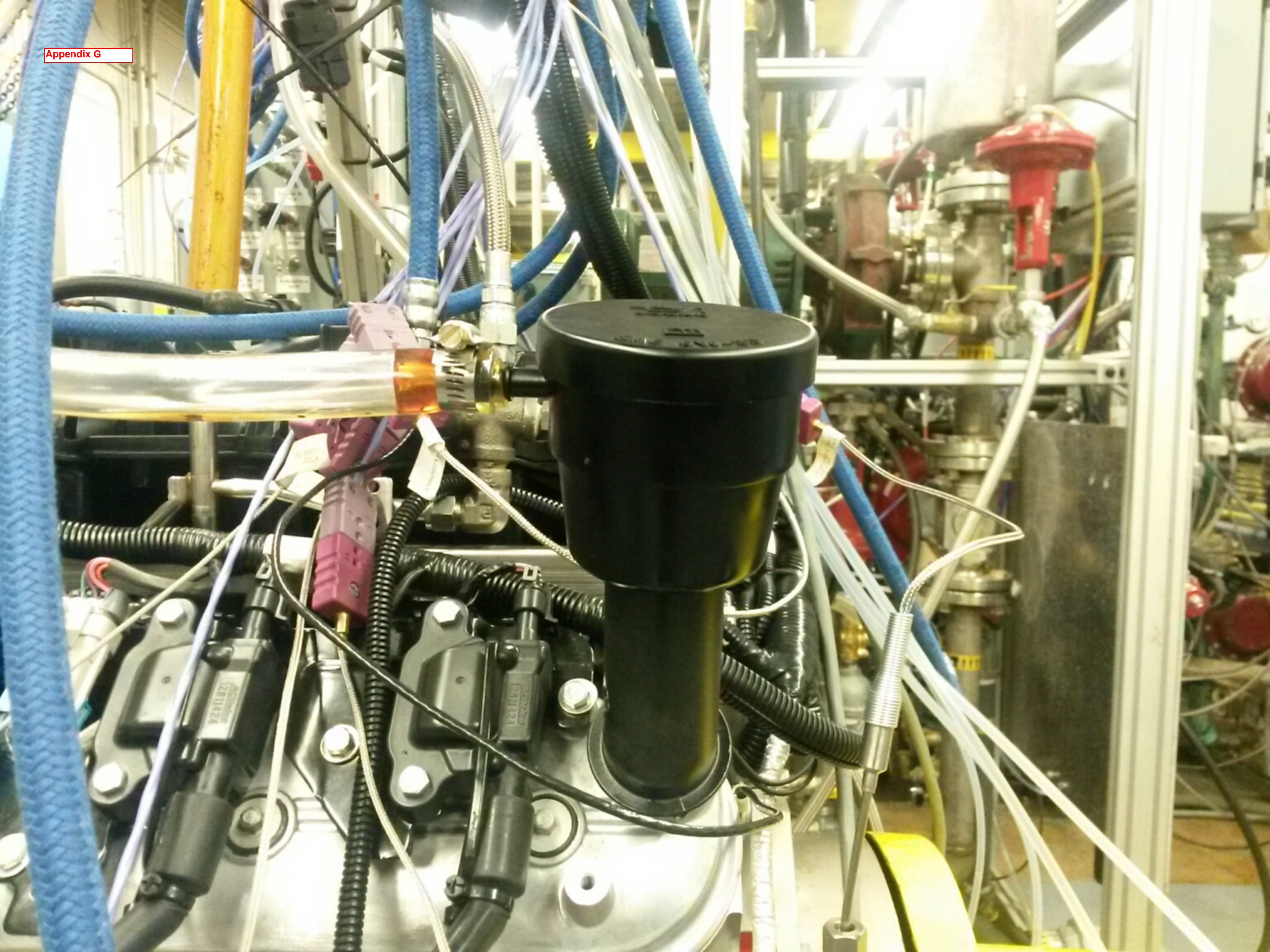

Appendix G

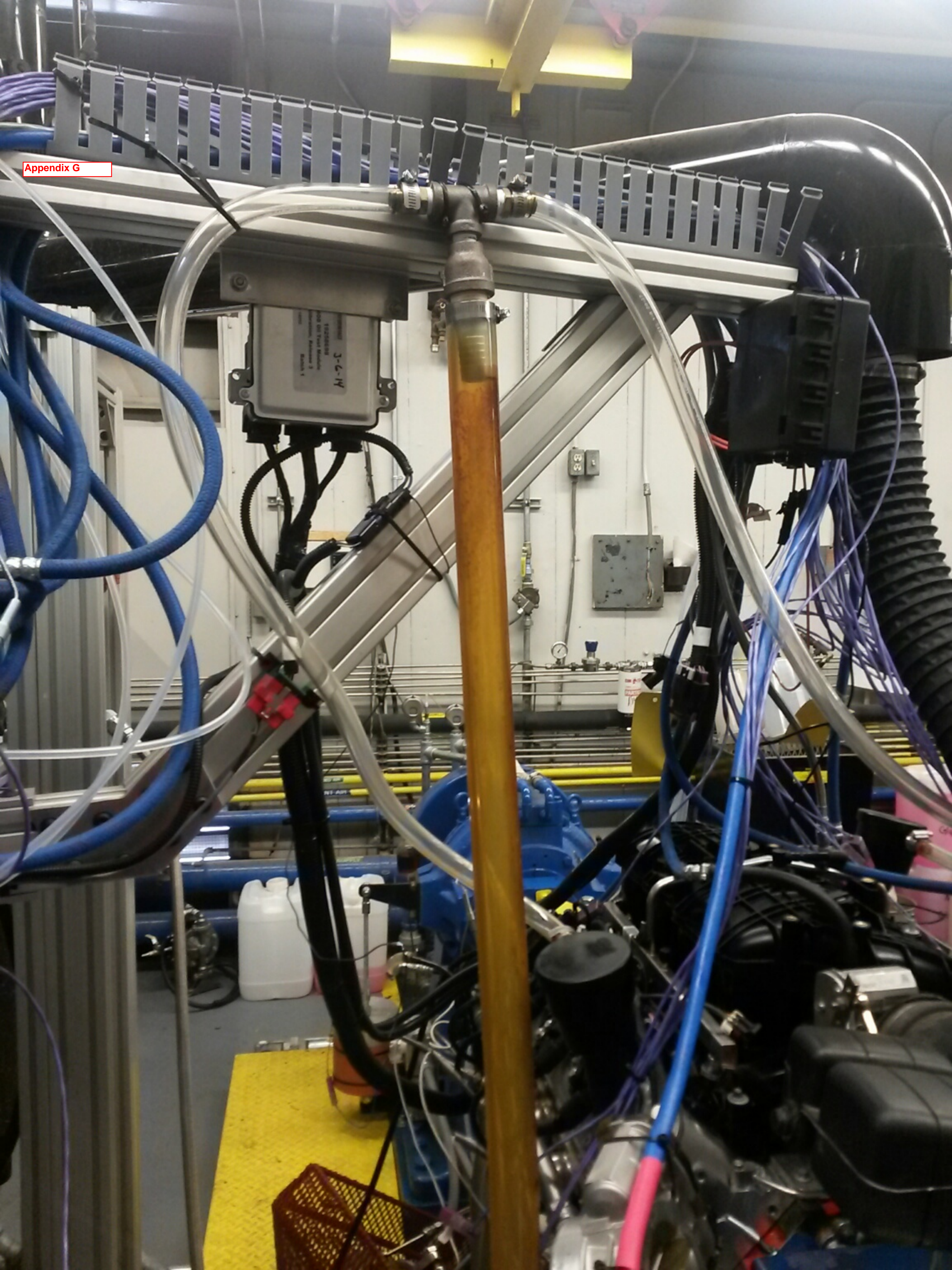

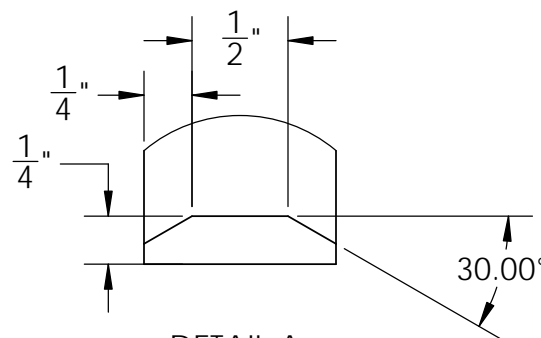
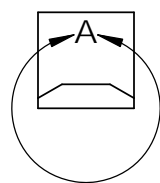
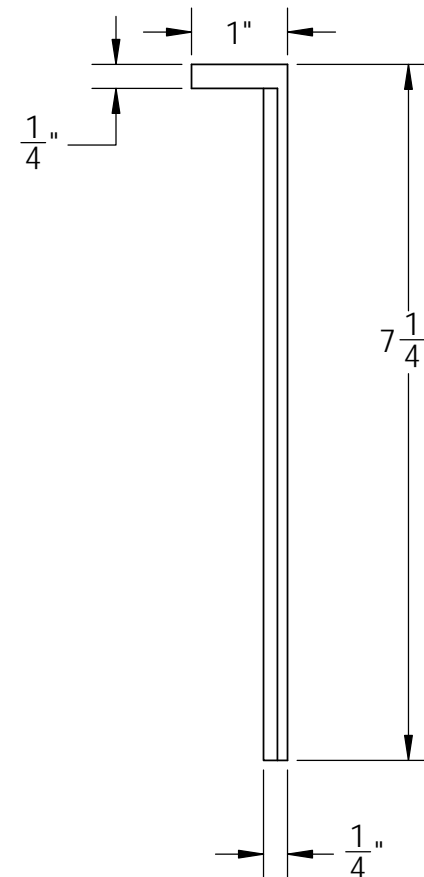
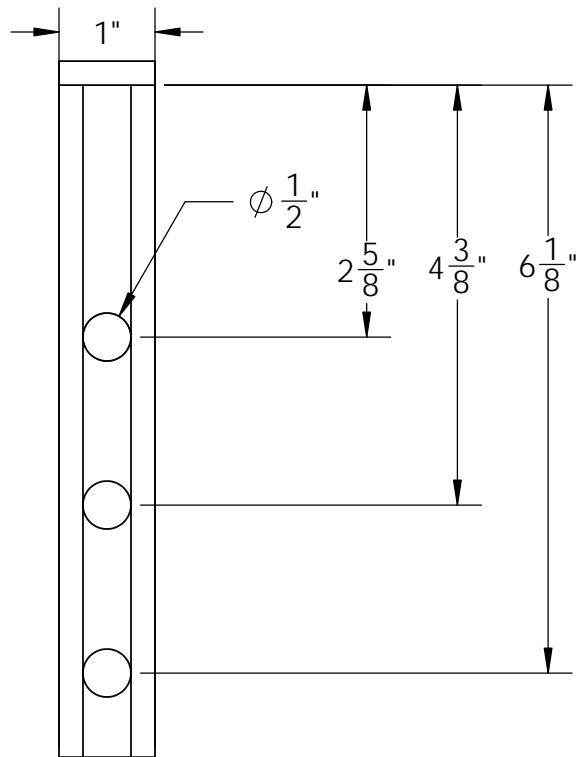
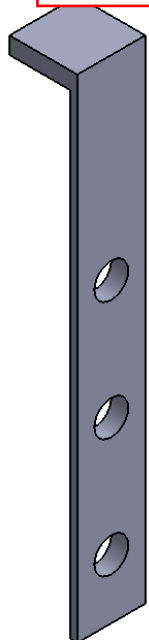

DETAIL A  
SCALE 1 : 1

SOLIDWORKS Drawing Provided by  
Intertek Automotive Research

		UNLESS OTHERWISE SPECIFIED:		NAME	DATE	TITLE: <b>GMOD Bore Measurement Ladder</b>		
		DIMENSIONS ARE IN INCHES						
		TOLERANCES:		DRAWN				
		FRACTIONAL ±		CHECKED				
		ANGULAR: MACH ± BEND ±		ENG APPR.				
		TWO PLACE DECIMAL ±		MFG APPR.		SIZE	DWG. NO.	REV
		THREE PLACE DECIMAL ±		Q.A.		<b>A</b>		
		INTERPRET GEOMETRIC TOLERANCING PER:		COMMENTS:		SCALE: 1:2	WEIGHT:	SHEET 1 OF 1
		MATERIAL						
		1/4" Aluminum Plate						
		FINISH						
	NEXT ASSY	USED ON						
	APPLICATION		DO NOT SCALE DRAWING					