



GMOD TEST STAND MANUAL (TSM)

12-21-2015

Bruce S Matthews
Bruce.matthews@gm.com

Table of Contents

1.	Mounting the Engine on the Test Stand	p. 2
2.	Dynamometer	p. 2
3.	Engine to Dyno Driveline	p. 2
4.	External Engine Oil Circuit	p. 2
5.	Induction System	P. 3
6.	Exhaust System	P. 4
7.	Fuel System	p. 5
8.	Engine Cooling System	p. 5
9.	Crankcase Ventilation System	p. 5
10.	Additional Requirements	
	10.01 Cylinder Surface Finish Analyzer Fixture	p.9
	10.02 Test Cell Ambient Thermocouple	p. 9
11	Appendix	
	11.01 Appendix A, Flywheel Adapter Plate	p.10
	11.02 Appendix B,	
	11.02.1 External Oil System setup and Flow Direction,	P. 12
	11.02.2 Camaro Oil Cooler Plate Sheets 1, 2 and 3	p. 13-15
	11.03 Appendix C, Airbox thermocouple/pressure transducer	P. 16-24
	11.04 Appendix D, Throttle Body Lever Arm,	p. 25
	11.05 Appendix E, GMOD Exhaust Down-Pipe Taps,	p. 26
	11.06 Appendix F Surface Finish Analyzer Support Drawings,	p.26-39
	11.07 Appendix G Crankcase Ventilation System,	p. 40-41
	11.08 Appendix H, Bore Measurement Ladder	p.42

1. **Mounting the Engine on the Test Stand**---Mount the engine on the test stand according to the following:
 - 1.01 Use OHTGMOD-006-1 front and OHTGMOD-007-1 rear engine mounts.
 - 1.02 Use Mercury Quicksilver 66284A engine mounts.
 - 1.03 Level the engine so it is at 0.0 degrees side-to-side and 90 degrees on the flywheel face. Connect the driveline between the engine and dyno.

- 2.0 **Dynamometer**--- A Midwest 1014 dynamometer is to be used.
 - 2.01 The engine shall start using an air starter mounted on the rear of the dynamometer capable of cranking the engine at 300 +/- 50 rpm with spark plugs removed.
 - 2.02 **Dynamometer Load Cell Temperature Control.** Control the load cell temperature. Enclose the dynamometer load cell to protect it from the variability of laboratory ambient temperatures. Maintain air in the enclosure within the operating temperature range specified by the load cell manufacturer within a variability of no more than 6 °C. Control temperature by a means that does not cause uneven temperatures on the body of the load cell.

- 3.0 **Engine to Dyno Driveline**---Connect the engine to the dyno in the following manner:
 - 3.01 The driveline must meet the MSI-41RE-xx specification.

MSI = Machine Service, Inc

41RE = 1410 series Dana shaft w/rubber isolation

“xx” =driveshaft length
 - 3.02 To connect the driveline to the engine flywheel use adapter plate in Appendix A.

- 4.0 **External Engine Oil Circuit**---This oil circuit includes a filter and a heat exchanger.
 - 4.01 Use the Canton Remote Filter Adapter part # CTR-22-598 and O-ring Kit CTR-98-004.
 - 4.02 Use OHT6A-012-4 Oberg oil filter housing with OHT6A-013-3, 60 micron filter.
 - 4.03 Use the Camaro oil cooler, 12607900 as supplied by Chevrolet Performance Warehouse (CPW). This cooler is to be mounted vertically to

aid in bleeding air from the system as shown in Figure 1.



Figure 1

- 4.04** Refer to the drawing “Camaro Oil Cooler plate” sheet 1, 2, and 3 in Appendix B2 to mount the cooler. McMaster Carr 4464K473 Type 304 Stainless Steel Half Coupling is used with this plate to connect the oil/coolant hoses.
- 4.05** External oil circuit configuration. See Appendix B1. The oil will exit the engine through the Canton remote oil filter adapter to the Camaro oil cooler to the Oberg filter then back to the Canton adapter and into the engine block.
- 4.06** External oil circuit hose and fitting specifications. Number 10 A/N fittings and braided lines are to be used. No 90 degree fittings are to be used, only straight or 45 degree to reduce the pressure drop. The total line length is to be 50 in. +/- 2 in. The capacity of this oil circuit must be kept to a minimum so as much oil remains in the engine at all times.

5.0 Induction System.

- 5.01** Use these air intake GM part numbers. Air box 92230374, air filter 92196275, and air duct 92196314.
 - 5.01.1** The air filter is to be replaced a minimum of once per reference period (15 candidate tests or 120 days).
 - 5.01.2** There must be no bends in the bellows of the air duct where it attaches to the air filter housing. The intake air needs to remain straight as it exits the MAF sensor and travels through the bellows. Any bends will cause inaccurate readings by the MAF sensor.
- 5.02** Airbox thermocouple and pressure transducer location are in Appendix C.
- 5.03** Use two throttle bodies both are part number 12629992 available from GM Dealerships. One with the modified throttle linkage is mounted on the engines intake manifold. A second throttle body is connected to the wiring harness and mounted at the stand.



Figure 2



Figure 3

5.04 Intake Manifold Vacuum. Use a transducer having a range of 0 to 100 kPa. Connect the transducer to port indicated in figures 2 and 3.

5.05 Engine throttle body lever arm. See Appendix D.

5.06 The production MAP sensor is not connected to the wiring harness. This sensor can be removed and the hole permanently plugged to prevent vacuum leaks. Refer Figure 2 for MAP sensor location.

6.0 Exhaust System.

6.01 Use exhaust manifolds and take down tubes, OHTGMOD-017-1.

6.02 The process water enters the exhaust manifold through the bottom and exits the top in a counter-flow orientation.

6.03 Exhaust back pressure valves are required to maintain 3 kPa. See Appendix E.

6.04 O₂/NO_x sensors are located on the take down tubes. See Appendix E.

6.05 ECM NOx 5210t sensor is to be used in the down tube of each bank. See Appendix E. Information can be obtained from ECM, sales@ecm-co.com

7.0 Fuel System

- 7.01** The fuel pressure at the fuel rail is to be controlled to 410 kPa and 35 C +/- 2 C.
- 7.02** Install the fuel thermocouple and the fuel pressure sensor on the inlet side of the fuel rail as shown in the picture below section 5.03 of this document.
- 7.03** Flow test the fuel injectors before each test according to the procedure in the GMOD Engine Build Manual, Section 5 sheet 12.
- 7.04** Fuel rail inlet tube caution note. On the inlet tube to the fuel rail is a crimp which is used in production vehicles to securely attach the fuel feed hose to

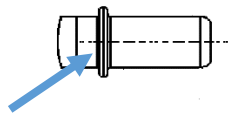

the fuel rail. A crack has been known to form around this crimp causing fuel to leak in engine dynamometer applications. The best practice for attachment of the fuel line to the fuel rail therefore is behind the crimp after the inlet tube on the fuel rail is shortened. See picture in 5.03.

8.0 Engine Cooling System

- 8.01** Use the coolant manifold OHTGMOD-008-1
- 8.02** The coolant flow rate is to be controlled by a variable-frequency drive (VFD) pump with no control valves downstream of the engine.
- 8.03** Use 100% ShellZone® Extended Life DEX-COOL®.
- 8.04** The coolant reservoir tank is to be controlled to a pressure of 123 kPa.
- 8.05** A resistance value of 115.2 ohms is used for the coolant temperature sensor electrical circuit when the test is at operating conditions. This circuit is bypassed for engine starts when the coolant sensor is referenced by the ECM. With the 115.2 ohm circuit the ECM will display a 115C coolant temperature on the OBDII data stream when recorded at the test stand.

9.0 Crankcase Ventilation System

- 9.01** Camaro oil separators, part number 12653073, are to be installed on the oil fill tubes, part number 12584043, in both rocker covers, part number 12582224. When installed correctly the top surface of the separator is horizontal.
- 9.02** Use 0.625" inside diameter tygon hose from the Camaro oil separators to 5/8" barbed adapters and 1/2" pipe Tee fitting above engine. See pictures in Appendix G. page 39 – 40.
- 9.03** The 1/2" pipe Tee fitting and barbed adapters are to be positioned 6" +/- 3" above the engine.
- 9.04** Either the sharp edged orifice or the J-TEC can be used to measure blowby. When the J-TEC is used blow-by gases only flow through the

meter when the measurement is taken. At other times these gases are vented to atmosphere prior to the J-TEC meter.

9.05 GMOD Engine J-TEC Model VF563AA Setup and Maintenance Procedure

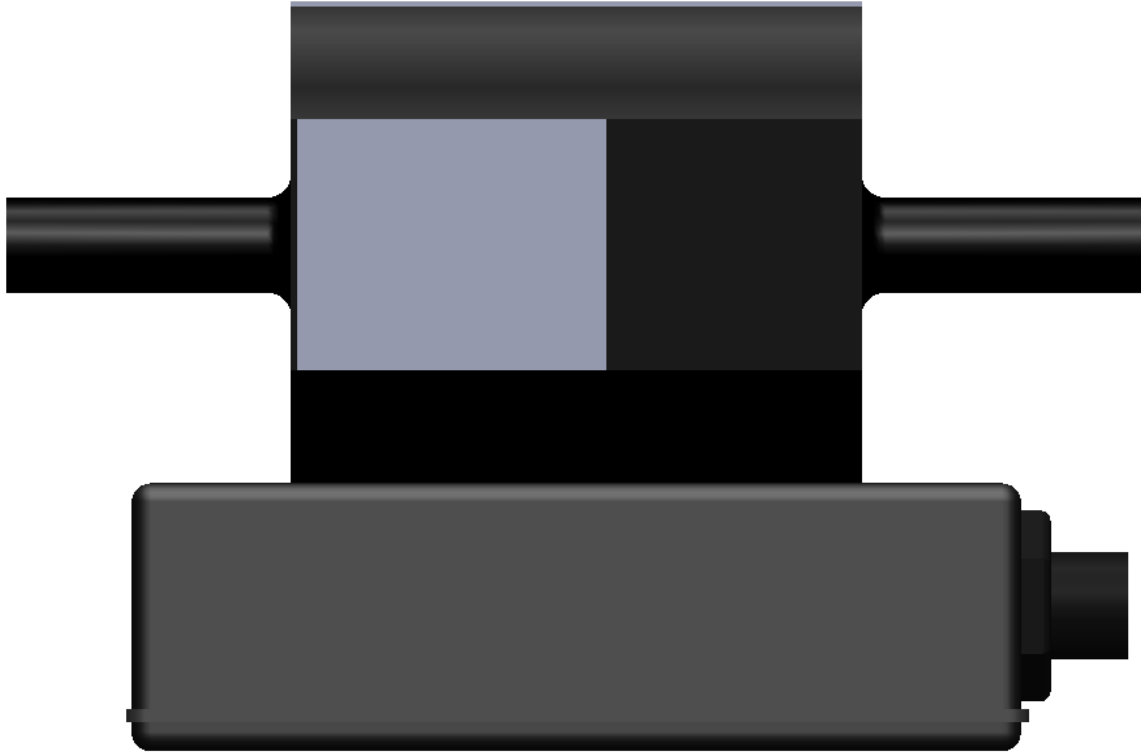

INSTALLATION INSTRUCTIONS

- 1) The flow meter must be installed with a minimum of 20 pipe diameters of straight pipe upstream and 10 pipe diameters downstream from the flow meter. For example, a one-inch tube or hose must have 20 inches of straight length immediately before the flow meter inlet tube. This condition provides a more symmetrical flow profile, which is necessary to obtain accurate and repeatable results.
- 2) A typical connection to the flow meter is made by placing flexible hose onto the outside of the inlet tube and outlet tube.
- 3) Install the flow meter vertical with flow into the top and out the bottom to encourage liquids to drain out of the flow meter.
- 4) Installing a VF563 CCV6000 filter canister (or buffer chamber) in the pipe between the crankcase and the flow meter minimizes the effect of pulsating flows, and collect oil and water droplets to keep the flow meter cleaner.

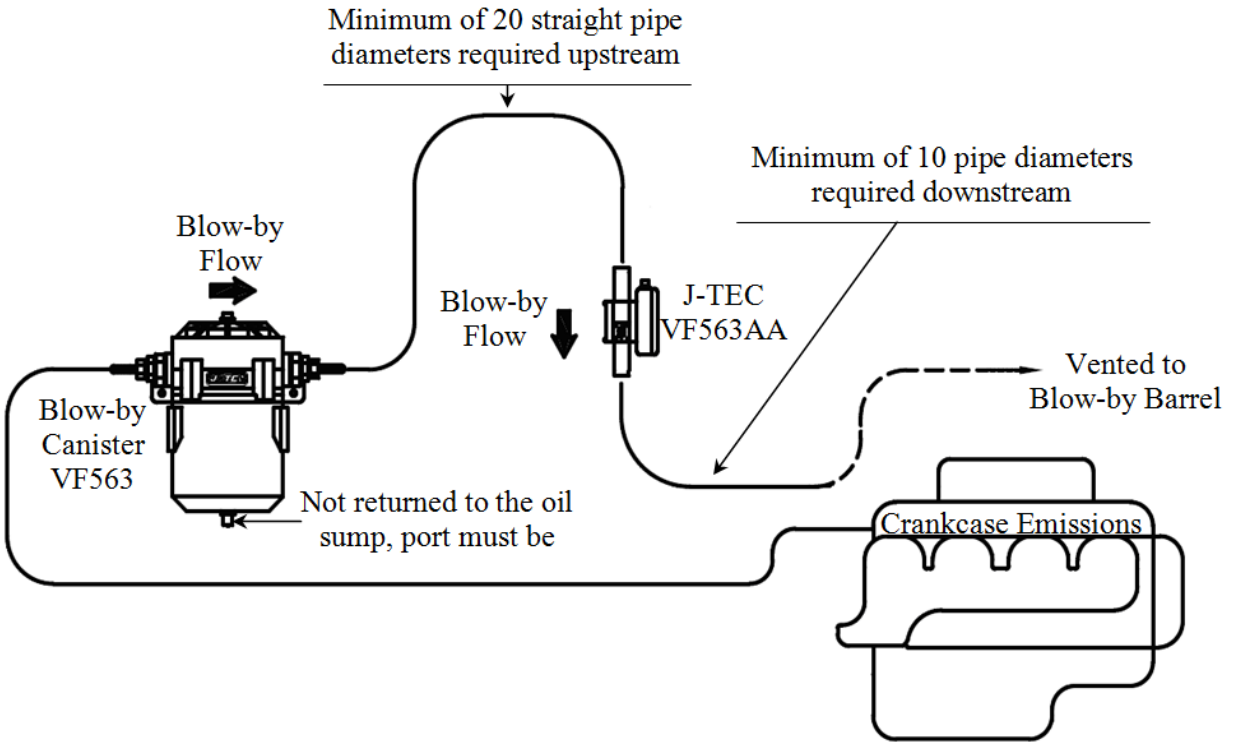

FIGURE B
Engine Blow-By Measurement System

CLEANING AND MAINTENANCE

The inside of the flow tube and strut must be kept clean. This cleaning procedure is to be completed prior to every test start.

- 1) To clean the flow tube and strut, gently brush the inside of the tube with a soft brush or cotton swab. A solvent cleaner, such as a brake parts cleaner that degreases and leaves no residue, may be used to loosen deposits. Ensure the solvent is compatible with aluminum, viton, and Teflon.
- 2) DO NOT use wire brushes or use high-pressure liquids. These may cause damage to the transducers.

ELECTRICAL INSTALLATION

- 1) A filtered power supply must provide at least 35 mA at +12 to +24 Volts Direct Current (VDC).
- 2) Analog output signal is 0 to 5 volts DC, proportional to the flow range. (Output impedance is 100 ohms).
- 3) Four-conductor cable made of 26-22 AWG wire is required to make connections to the flow meter.

- 4) The contact pins, of the flow meter connector, are identified in Figure A. The mating connector, that connects to the flow meter head, is CONXALL part number 6282-5SG-3XX (J-TEC part number DRJ0720).

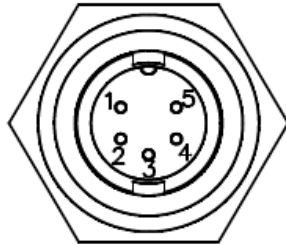

NOTE: Connector viewed from outside of flowmeter

Pin	Color	Description
5		Not Used
4	RED	Power Input (+12 to +24 VDC)
3	WHT	Output (0-5 VDC or Frequency)
2	BLK	Signal Ground
1	BLK	Power Ground

FIGURE A
Flowmeter Connector Pin-Outs

Recommended Electrical Connections
(separate grounds for lowest measurement error)

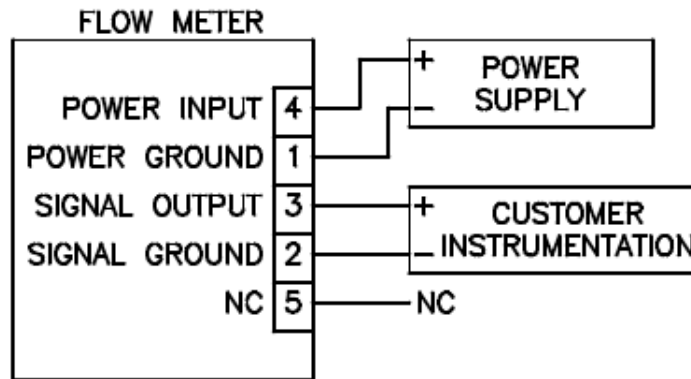

CIRCUIT BOARD OUTPUT JUMPERS

DAA0XXX-0003	ANALOG (0-5V)	P3-2 to P3-3
DAA0XXX-0002	FREQUENCY	P3-2 to P3-1

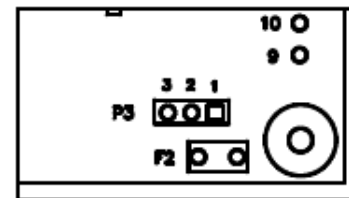

Citation

J-TEC Associates, Inc. MAN0062 Revision D (S/N 10000 & up). *Operator's Manual for the VF563 Series Flowmeter Installation*. (2013). PDF File.

10.0 Additional Requirements

10.01 Cylinder Surface Finish Analyzer Fixture. This fixture must be designed to the GMOD drawings in Appendix F.

10.02 Test Cell Ambient Thermocouple. A thermocouple is to be positioned 12" +/- 3" directly above the engine intake manifold to measure test cell temperature.

10.03 Thermocouple Locations. Install the sensing tip of all thermocouples in the center of the stream of the medium involved unless otherwise specified.

10.04 Engine Knock Sensors. The knock sensors are not to be bolted to the engine block. The wiring connector is to be plugged in to the sensor and tied back to the wiring harness away from the engine.

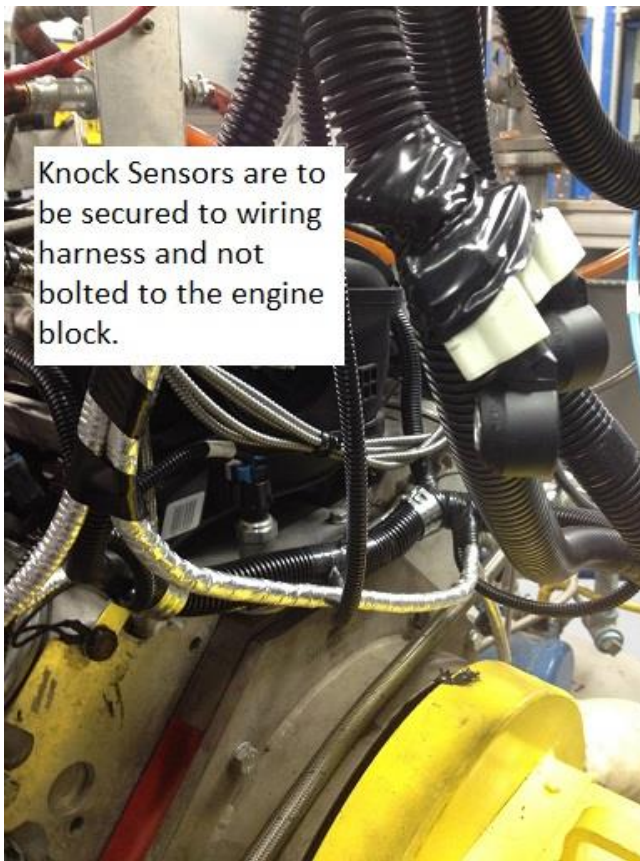

Appendix

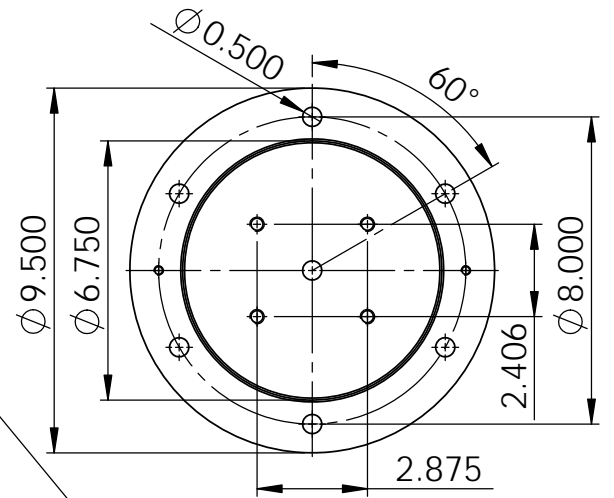
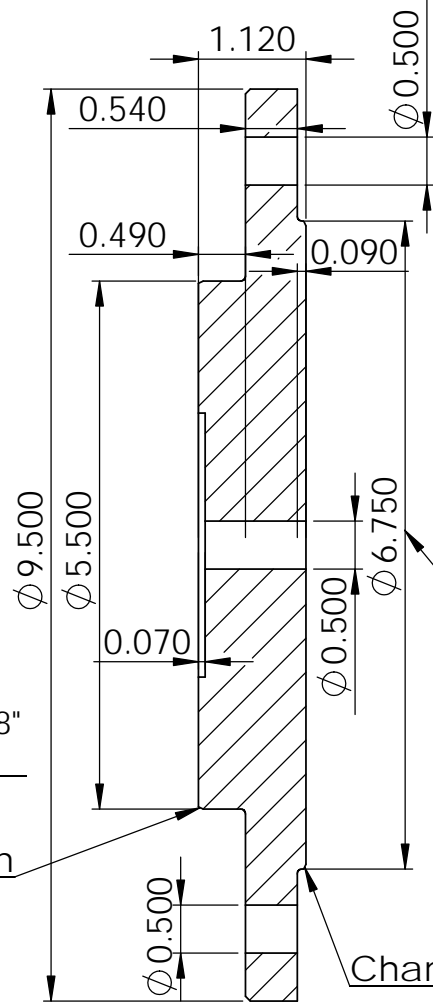
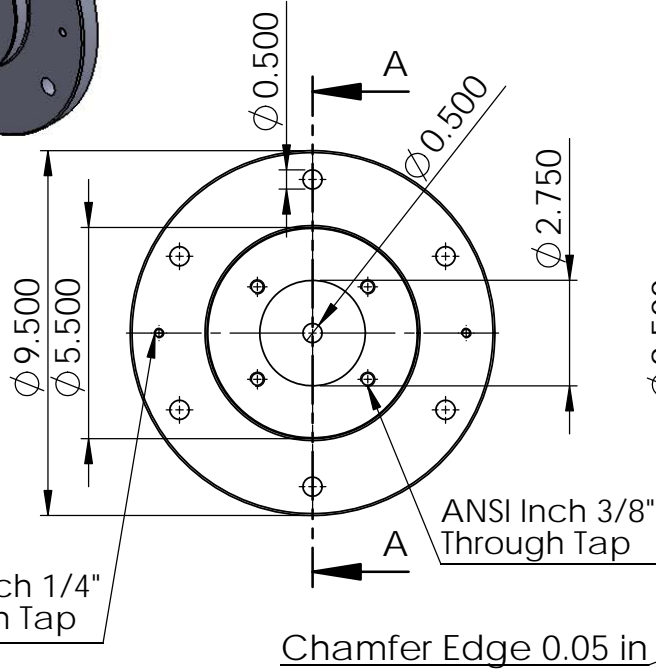
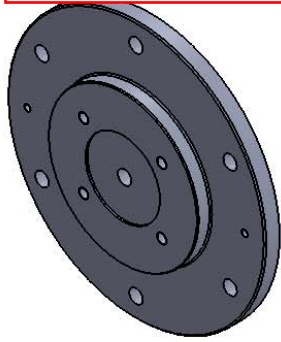

Balance Instructions:
Balance GMOD Flywheel Adapter and Flywheel Assembly with Grade 8 bolts statically or dynamically within 18 g*cm.

SECTION A-A
SCALE 1 : 2

Note: The 6 Through Holes on the GMOD Flywheel Adapter will need to be marked and modified to match the flywheel provided. The flywheel will need 6 ANSI Inch 1/2" Through Taps corresponding to the flywheel adapter dimensions provided in this Drawing.

SOLIDWORKS Drawing Provided by Intertek Automotive Research

		UNLESS OTHERWISE SPECIFIED:	NAME	DATE
		DIMENSIONS ARE IN INCHES	DRAWN	
		TOLERANCES:	CHECKED	
		THREE PLACE DECIMAL ± 0.005 in	ENG APPR.	
			MFG APPR.	
		INTERPRET GEOMETRIC TOLERANCING PER:	Q.A.	
		MATERIAL	COMMENTS:	
		A-36 Steel Plate		
NEXT ASSY	USED ON	FINISH		
APPLICATION		DO NOT SCALE DRAWING		

TITLE: GMOD Flywheel Adapter		
SIZE: A	DWG. NO.	REV
SCALE: 1:5	WEIGHT:	SHEET 1 OF 1

GMOD External Oil System Setup and Flow Direction Camaro Oil Cooler Heat Exchanger

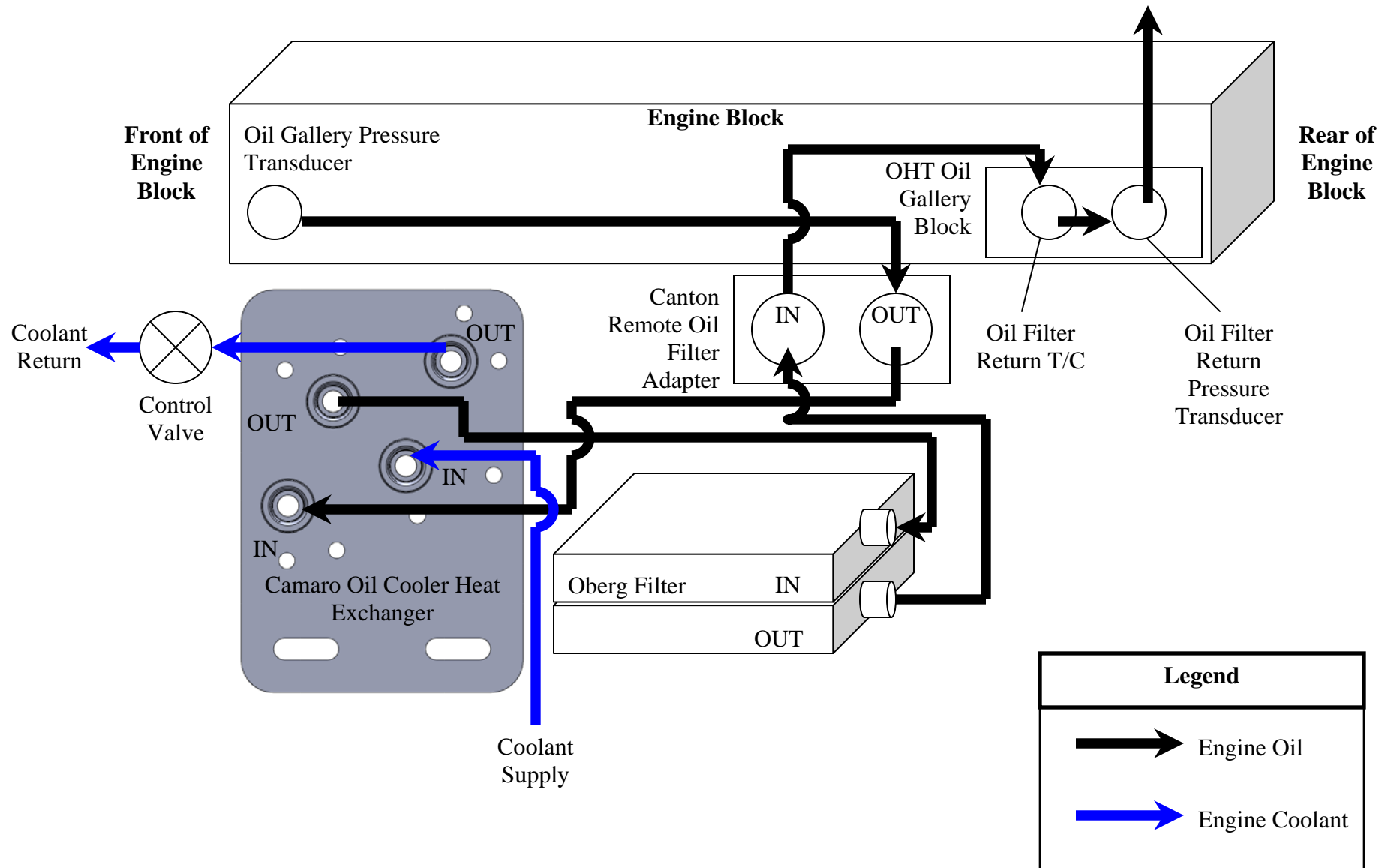

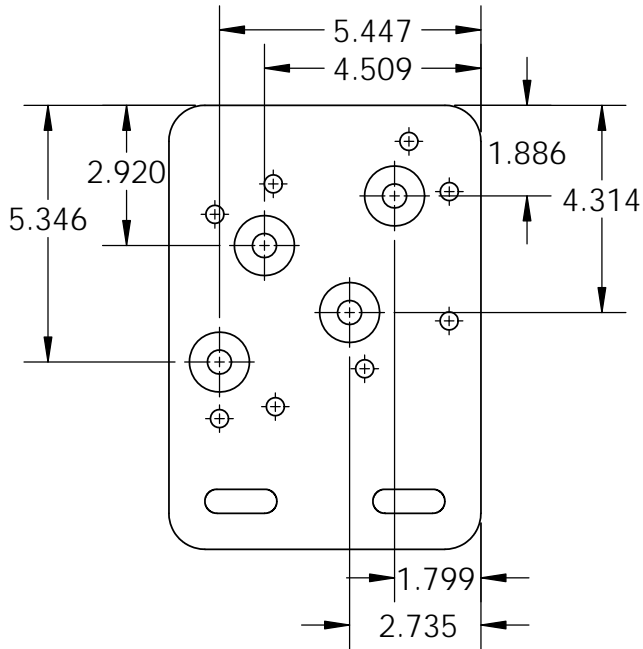
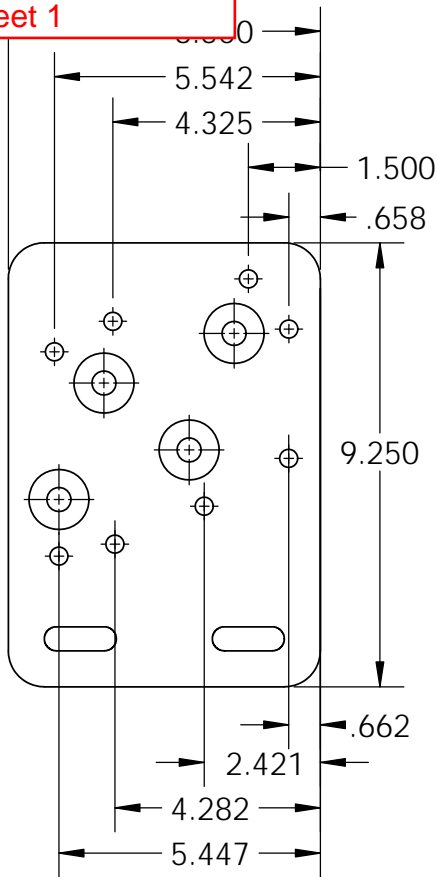

Type 304 Stainless Steel
Half Coupling (x4): 1/2
NPT Pipe Size, 14 Threads
Per Inch, 0.53" Thread
Engagement. A
McMASTER-CARR, Part
Number 4464K473, have
been found suitable.

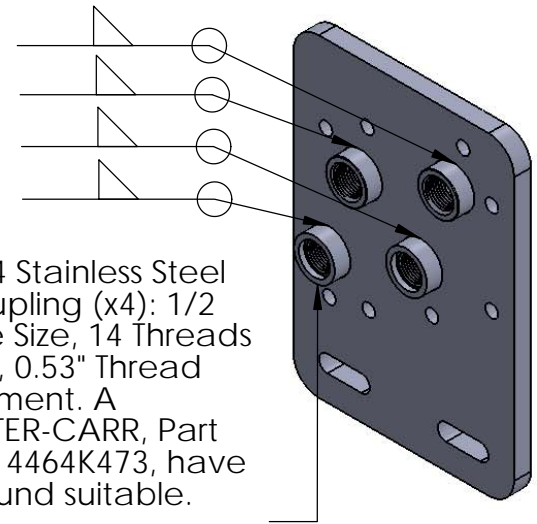

1.250 inch Diameter
Mill 0.250 inches
into Plate (x4)

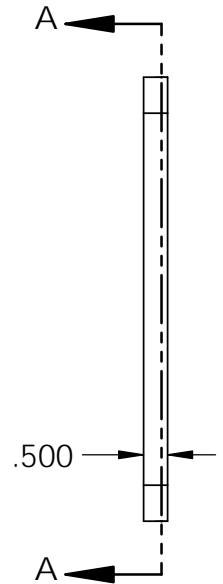
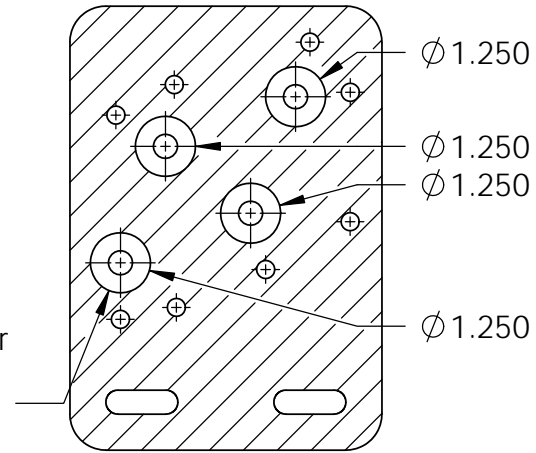

SOLIDWORKS Drawing Provided by
Intertek Automotive Research

UNLESS OTHERWISE SPECIFIED:

DIMENSIONS ARE IN INCHES
TOLERANCES:
THREE PLACE DECIMAL ± 0.002 in

MATERIAL **TYPE 304 SS**

DO NOT SCALE DRAWING

COMMENTS:

TITLE: **Camaro Oil
Cooler Plate -
Sheet 1**

SIZE A	DWG. NO.	REV
------------------	----------	-----

SCALE: 1:4	WEIGHT:	SHEET 1 OF 2
------------	---------	--------------

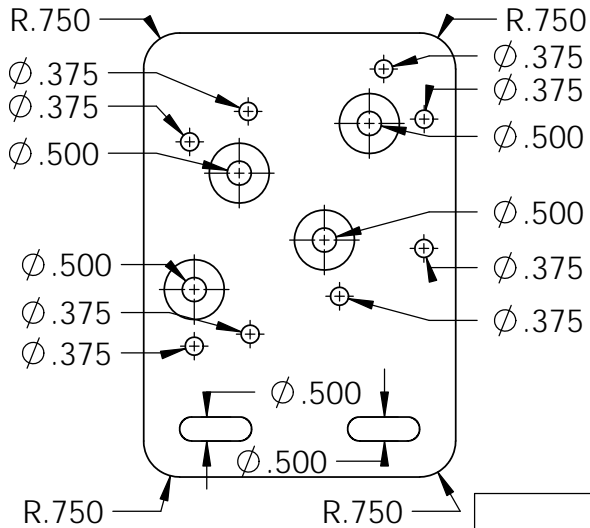
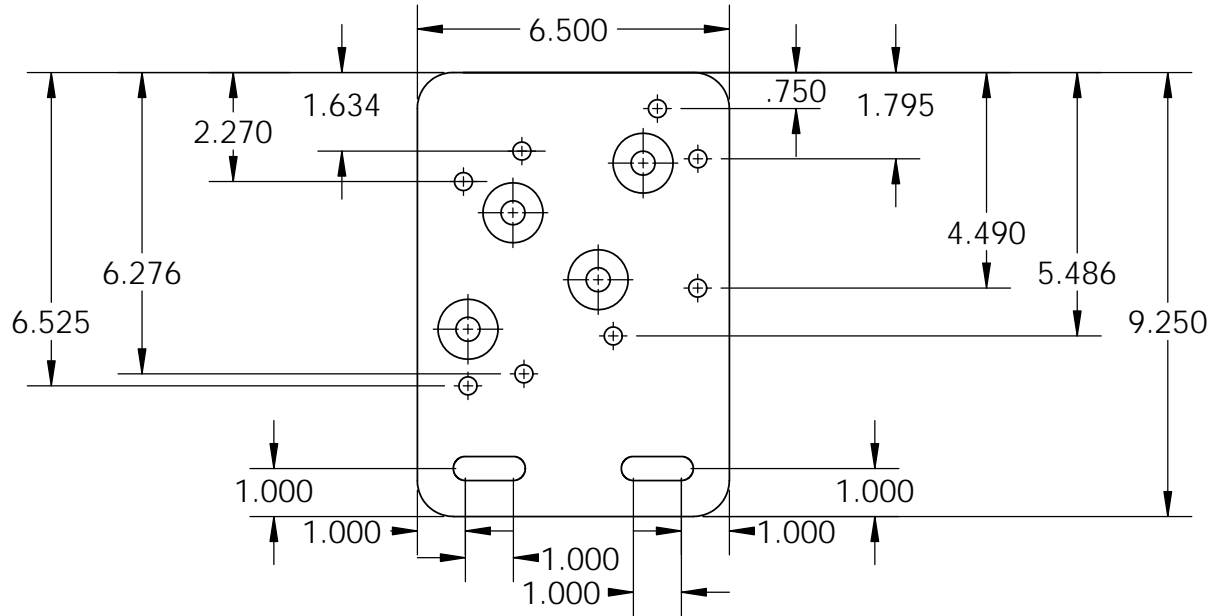

Note: Upon Completion of Welding the Half Couplings in Place, the Contact Surface between the Camaro Oil Cooler Plate and the Heat Exchanger will need to be End Milled Utilizing a Fly Cutter in Order to Ensure a Proper Sealing Contact Surface for the O-rings once Torqued to the Plate.

Milling

SOLIDWORKS Drawing Provided by
Intertek Automotive Research

		UNLESS OTHERWISE SPECIFIED:		
		DIMENSIONS ARE IN INCHES TOLERANCES: THREE PLACE DECIMAL 0.002 in		
		INTERPRET GEOMETRIC TOLERANCING PER:		
		MATERIAL TYPE 304 SS	COMMENTS:	
		DO NOT SCALE DRAWING		
		TITLE: Camaro Oil Cooler Plate - Sheet 2		
SIZE A	DWG. NO.	REV		
SCALE: 1:4	WEIGHT:	SHEET 2 OF 2		

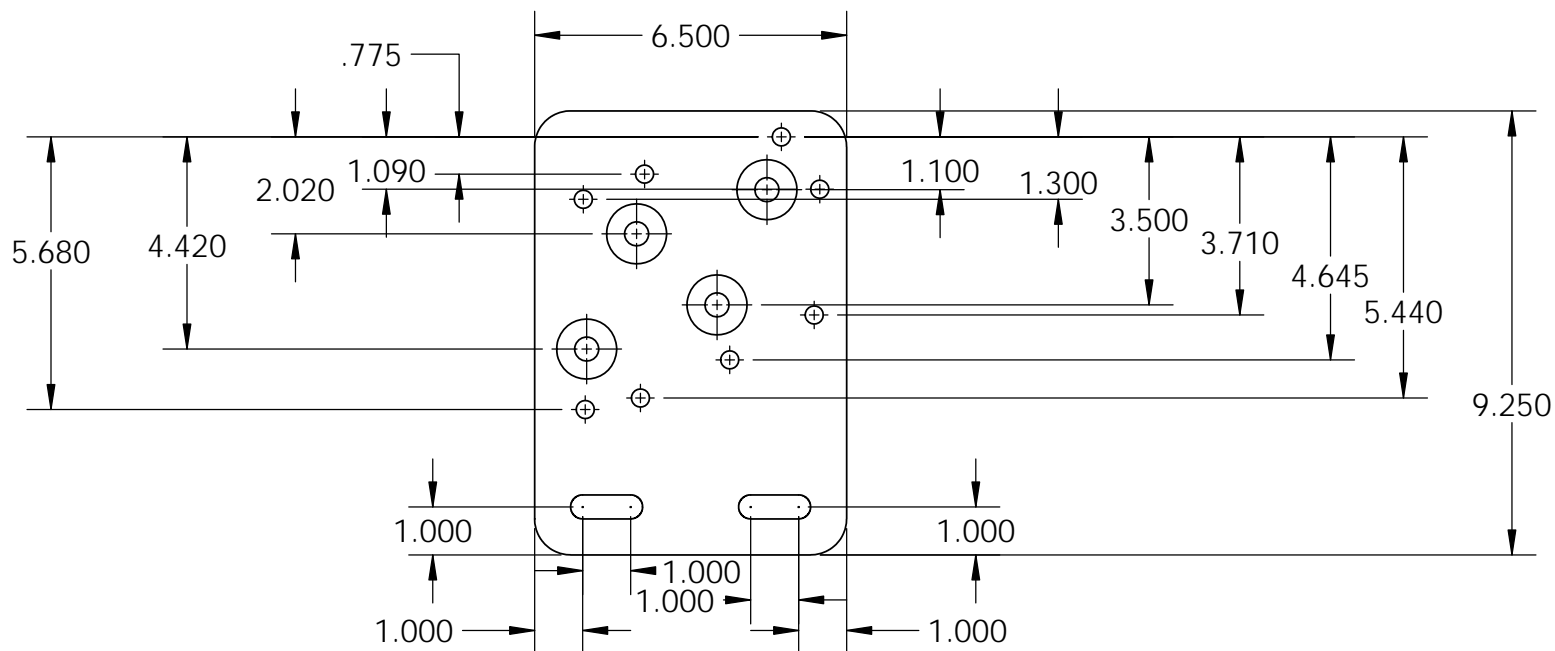

PROPRIETARY AND CONFIDENTIAL
 THE INFORMATION CONTAINED IN THIS DRAWING IS THE SOLE PROPERTY OF <INSERT COMPANY NAME HERE>. ANY REPRODUCTION IN PART OR AS A WHOLE WITHOUT THE WRITTEN PERMISSION OF <INSERT COMPANY NAME HERE> IS PROHIBITED.

		UNLESS OTHERWISE SPECIFIED:		NAME	DATE	TITLE: Camaro Oil Cooler Plate - Sheet 2					
		DIMENSIONS ARE IN INCHES TOLERANCES: FRACTIONAL ±	DRAWN						SIZE	DWG. NO.	REV
		ANGULAR: MACH ± BEND ±	CHECKED						A		
		TWO PLACE DECIMAL ±	ENG APPR.								
		THREE PLACE DECIMAL ±	MFG APPR.						SCALE: 1:4	WEIGHT:	SHEET 1 OF 1
		INTERPRET GEOMETRIC TOLERANCING PER:	Q.A.			COMMENTS:					
NEXT ASSY	USED ON	MATERIAL TYPE 304 SS									
APPLICATION		FINISH									
		DO NOT SCALE DRAWING									

Top blue circle is the pressure location, the lower blue circle is the temperature location

DIAMETER	UNIT	SURFACE	TOLERANCE
7	B	PIN	
7	H	PIN	

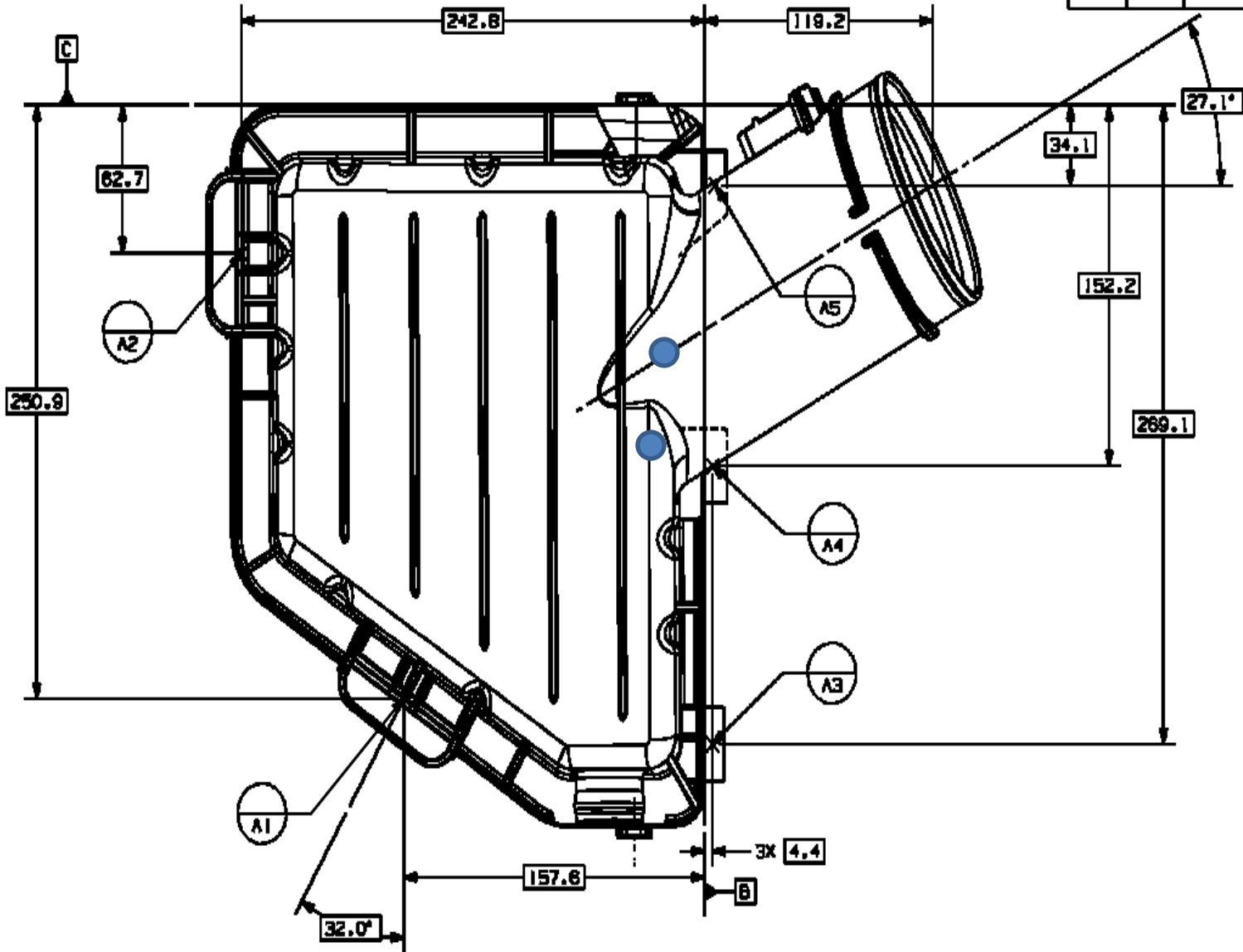

Since the datum points on this airbox are hole centers and the corners are rounded, I have chosen a groove molded into the cover as the reference point. The tip of the molded groove is one reference, and the other is the side of the groove closest to the holes.

The pressure probe and thermocouple are each installed to a depth of 50 ± 3 mm.

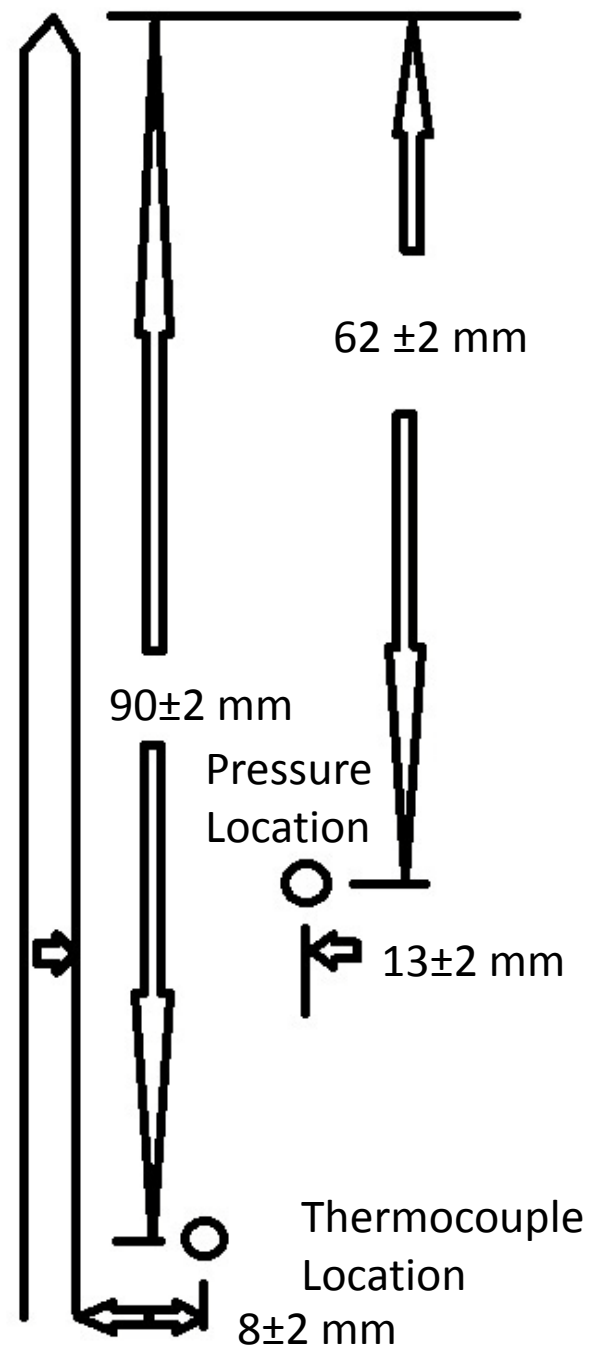

This probe design is commonly used in PCMO testing

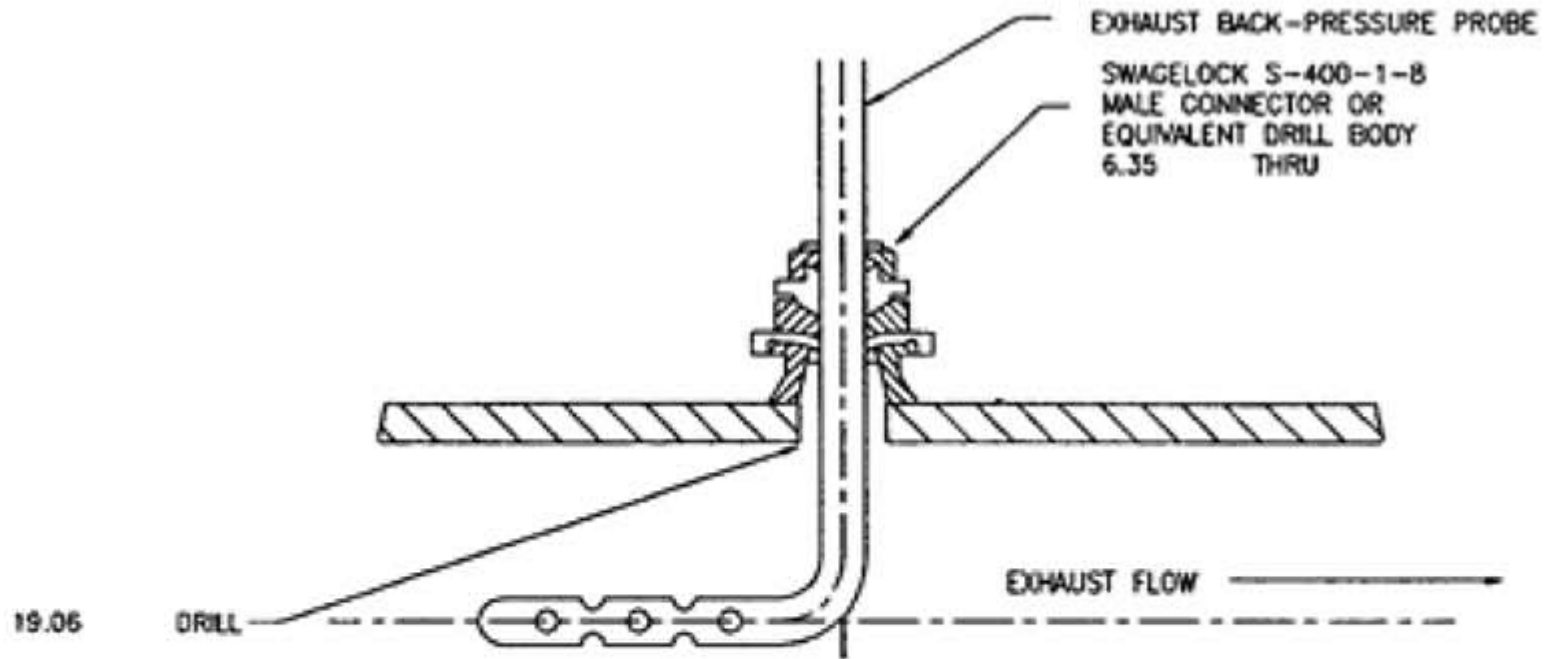

NOTE: BEND EXTERNAL TUBING
SEGMENT AFTER ASS'Y PARALLEL
WITH PROBE AXIS AS SHOWN.
THIS PERMITS VISUAL ALIGNMENT
CHECK DURING OPERATION.

ASSEMBLY DETAIL

Measurements are in millimeters

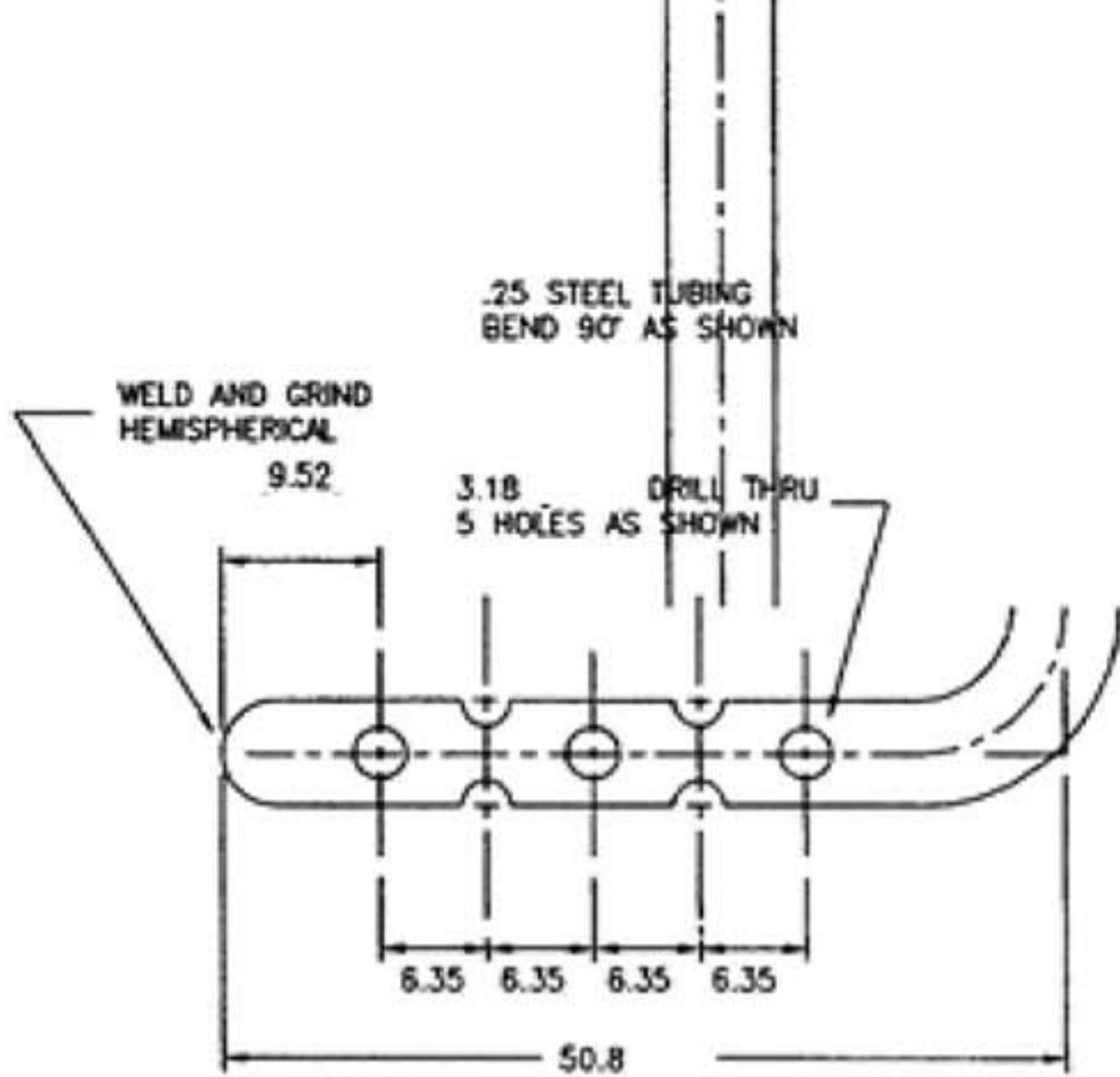

PROBE DETAIL

Top of airbox



Measurement for pressure tap





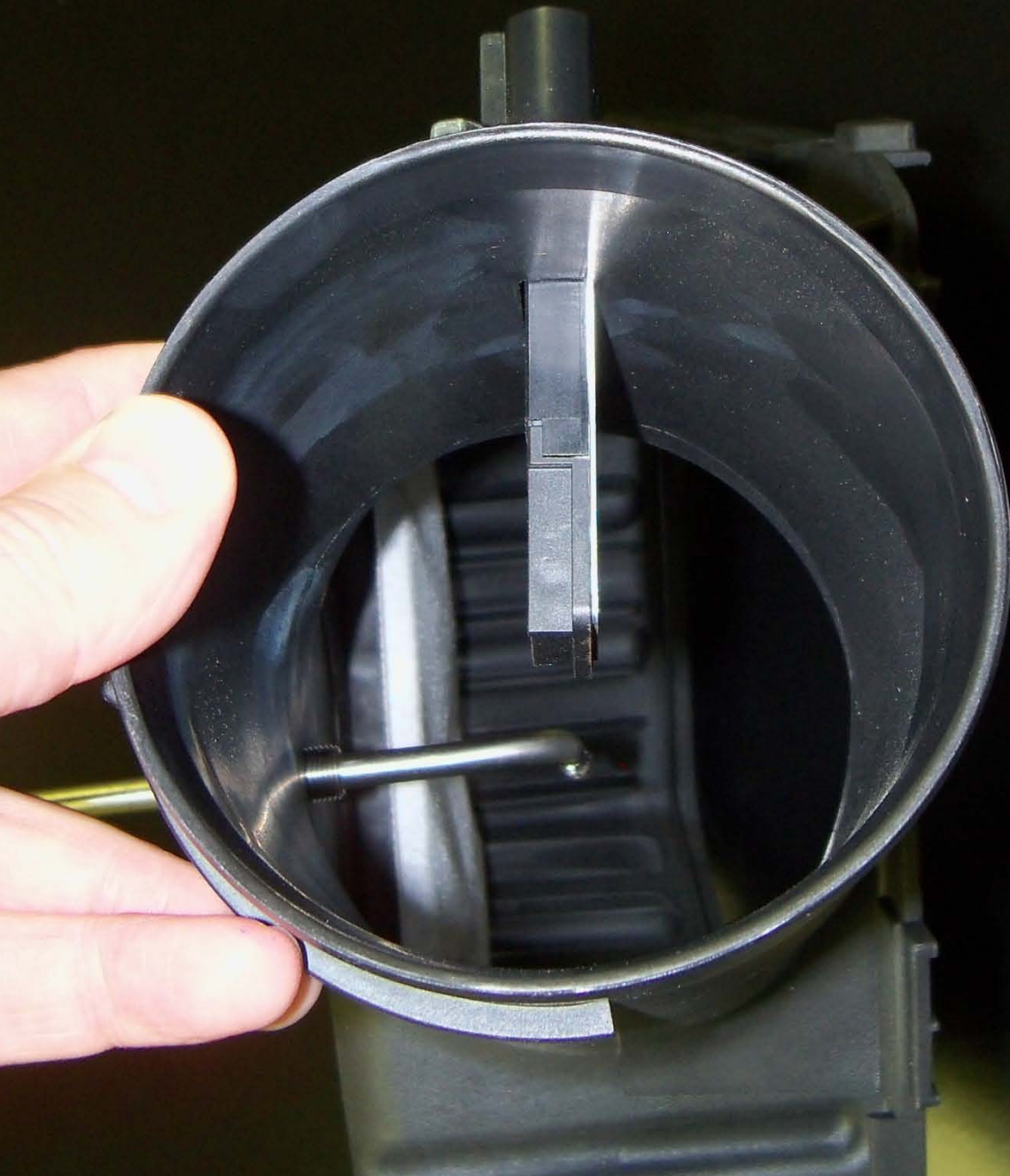

Thermocouple
will be below
the pressure
sensor



REVISIONS				
REV	SHT	ZONE	DESCRIPTION	DATE

GENERAL NOTES

- 1) DO NOT SCALE THIS DRAWING
- 2) UNLESS OTHERWISE STATED:
 - a. ALL DIMENSIONING AND TOLERANCING IS IN INCHES PER ASME Y14.5-2009
 - b. BREAK ALL SHARP CORNERS AND SHARP EDGES R .010 MAXIMUM
 - c. MACHINED SURFACE FINISHES SHALL BE 125 MICROINCH OR BETTER
 - d. TAP DRILL DEPTHS SHOWN ARE MAXIMUM
 - e. FULL THREAD DEPTHS SHOWN ARE MINIMUM
 - f. CHAMFER ALL TAPED HOLES TO (NOMINAL DIA + 1/16) x 90°
- 3) FINISH:

Appendix D

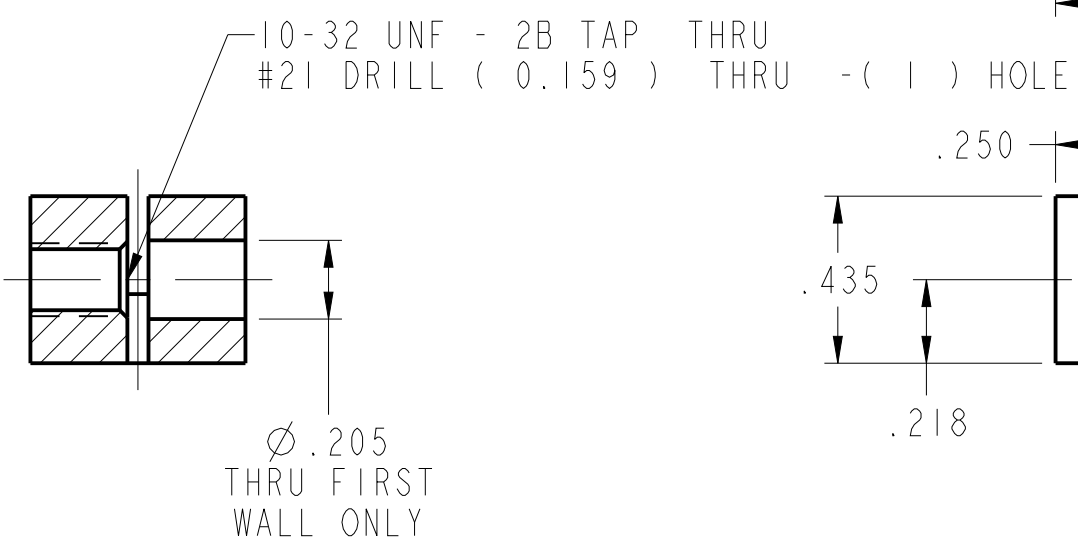
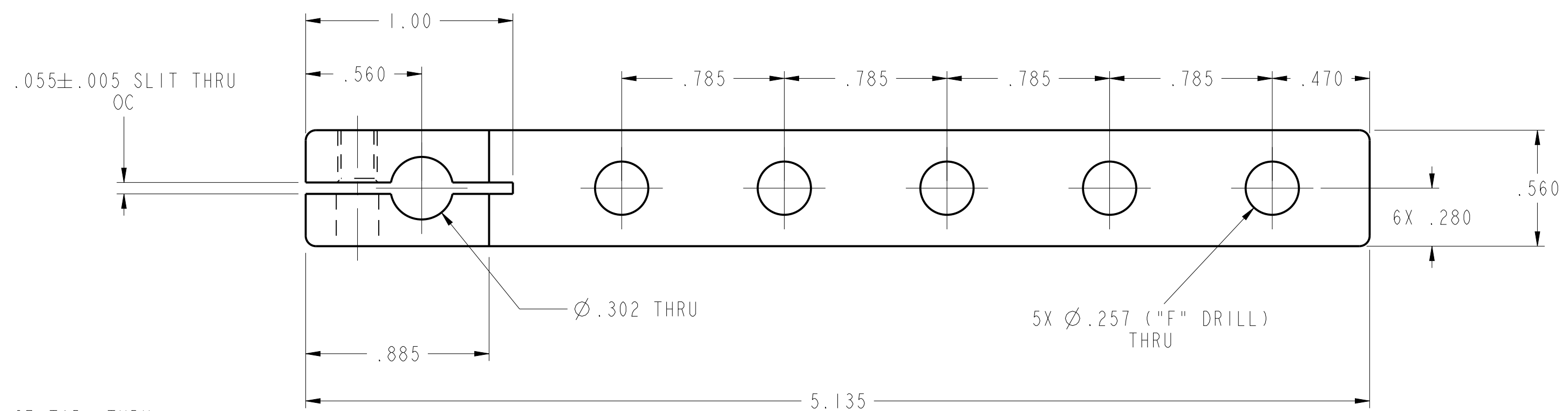
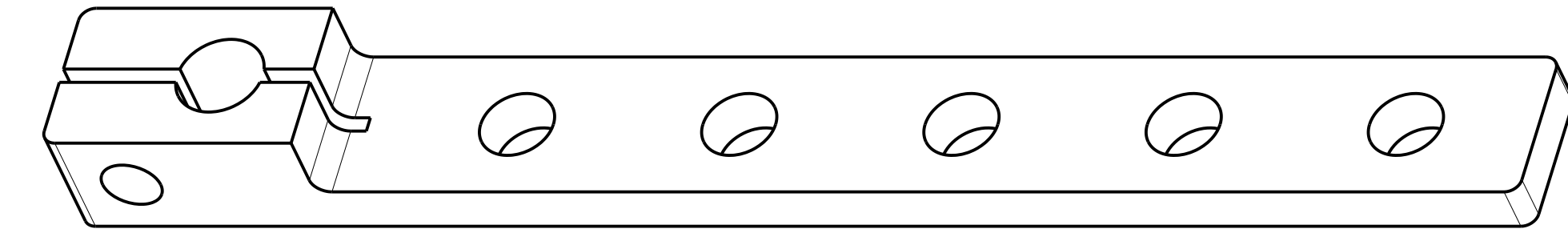

SECTION A-A

	-1	LEVER ARM	MILD STEEL	1
-1	CAGE	PART NUMBER	DESCRIPTION	MATERIAL/SPECIFICATION/NOTES
BILL OF MATERIAL/PARTS LIST				
DEFAULT TOLERANCES		APPROVAL SIGNATURES		
ONE PLACE (X.X) = ± 0.1	DESIGNER	T HABY		
TWO PLACES (X.XX) = ± 0.01	CHKD	C MARTINEZ		
THREE PLACES (X.XXX) = ± 0.005	PRD	C MARTINEZ		
FOUR PLACES (X.XXXX) = ± 0.0005	FILE	P LANG		
ANGLES = ± 0.5 DEGREE	DATE	COMPLETION DATE: 06 JAN 2014		
SURFACE FINISHES <= 125 MICROINCH RA	FILE	MODEL: THROTTLE_LEVER		
THIRD ANGLE PROJECTION		EXCEPT AS MAY OTHERWISE BE PROVIDED BY CONTRACT, THESE DIMENSIONS AND SPECIFICATIONS ARE THE PROPERTY OF SOUTHWEST RESEARCH INSTITUTE, ARE ISSUED IN STRICT CONFIDENCE, AND SHALL NOT BE REPRODUCED, OR COPIED, OR USED AS THE BASIS FOR MANUFACTURE OR SALE OF ANY APPARATUS SHOWN THEREON WITHOUT PERMISSION.		
D 26401		01910-431-400-001		
SCALE 2/1		UNIT WEIGHT = LBS		SHEET 1 OF 1

SwRI GMOD Exhaust pipe taps

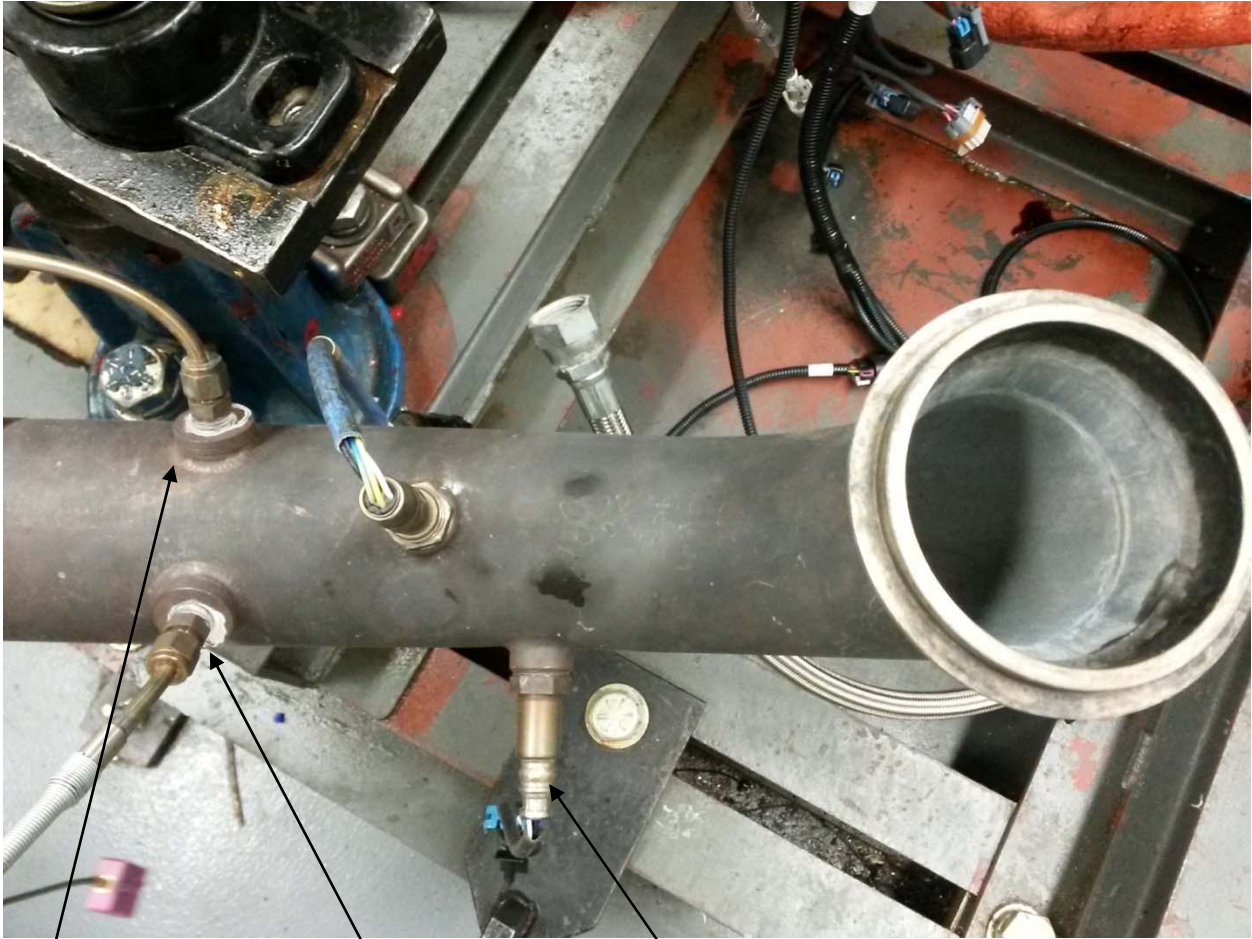

Exhaust Backpressure

Exhaust Temp

Stock Oxygen sensor

GENERAL NOTES

- 1) DO NOT SCALE THIS DRAWING
- 2) UNLESS OTHERWISE STATED:
 - a. ALL DIMENSIONING AND TOLERANCING IS IN INCHES PER ASME Y14.5-2009
 - b. BREAK ALL SHARP CORNERS AND SHARP EDGES R .010 MAXIMUM
 - c. MACHINED SURFACE FINISHES SHALL BE 125 MICROINCH OR BETTER
 - d. TAP DRILL DEPTHS SHOWN ARE MAXIMUM
 - e. FULL THREAD DEPTHS SHOWN ARE MINIMUM
 - f. CHAMFER ALL TAPED HOLES TO (NOMINAL DIA + 1/16) x 90°
- 3) FINISH:

REVISIONS				
REV	SHT	ZONE	DESCRIPTION	DATE

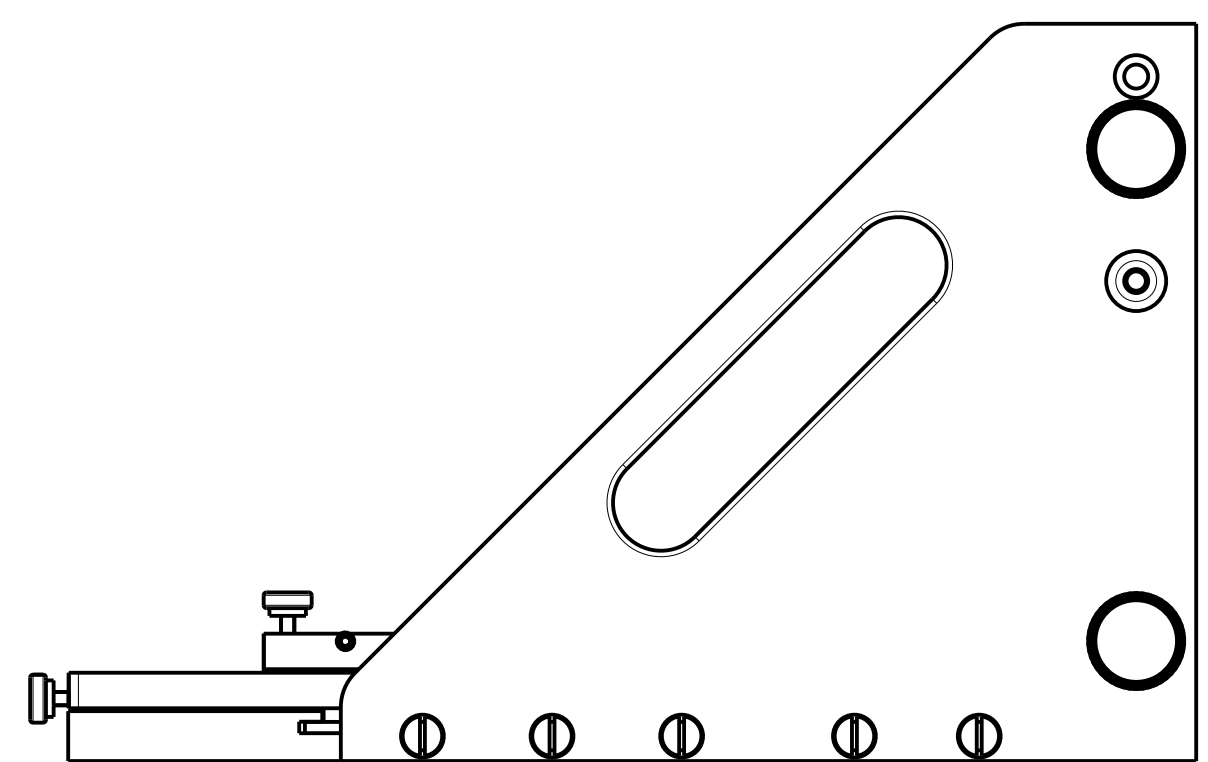
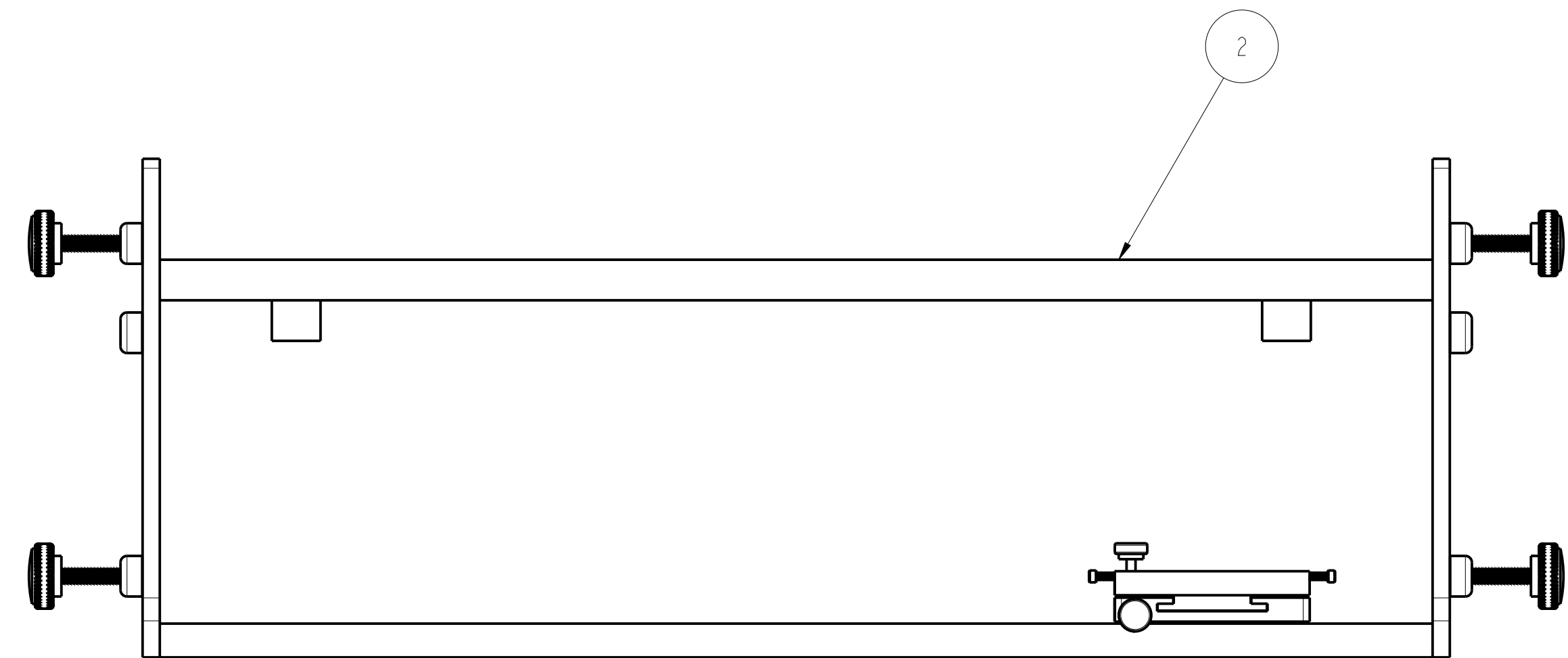
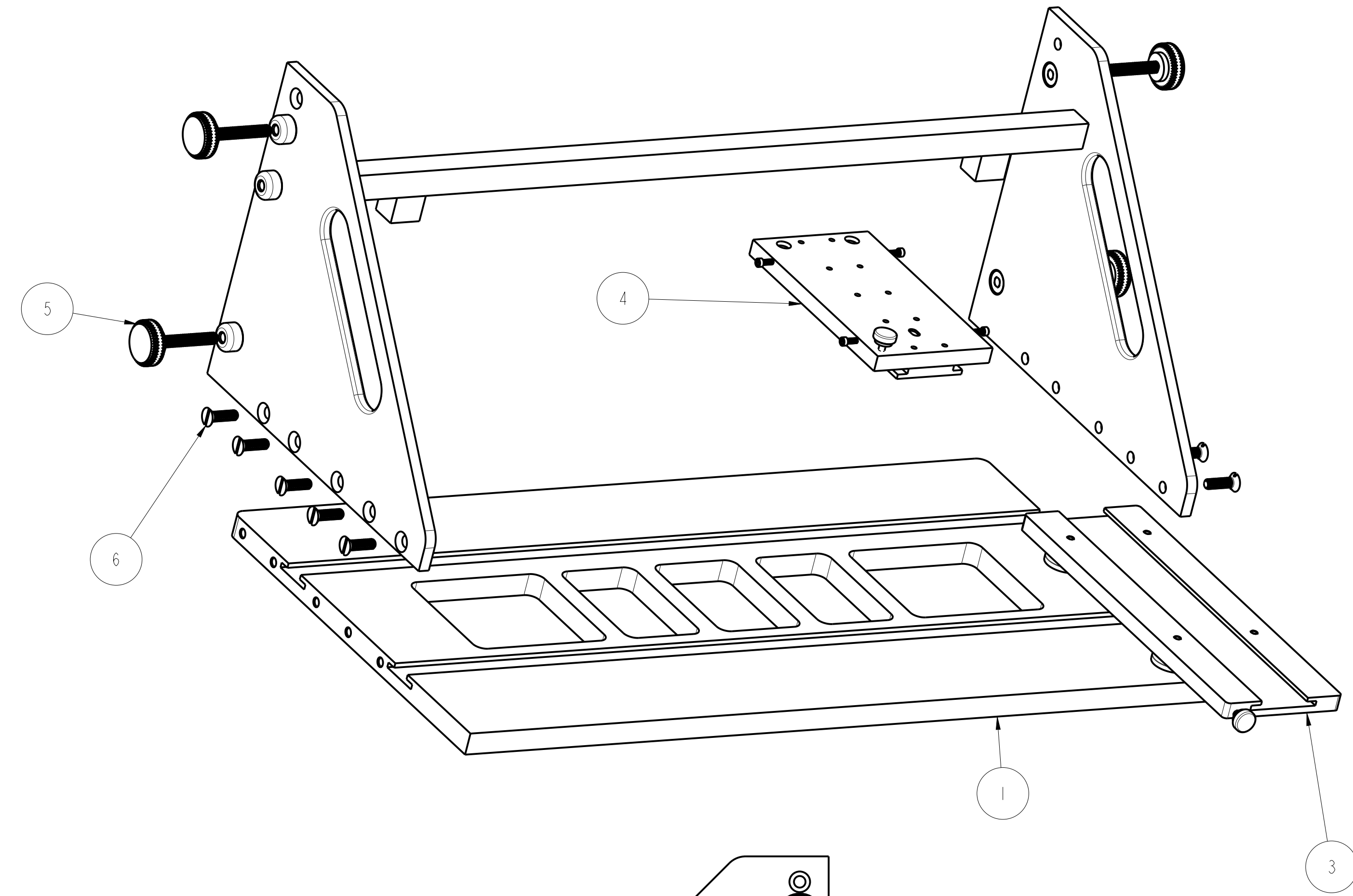
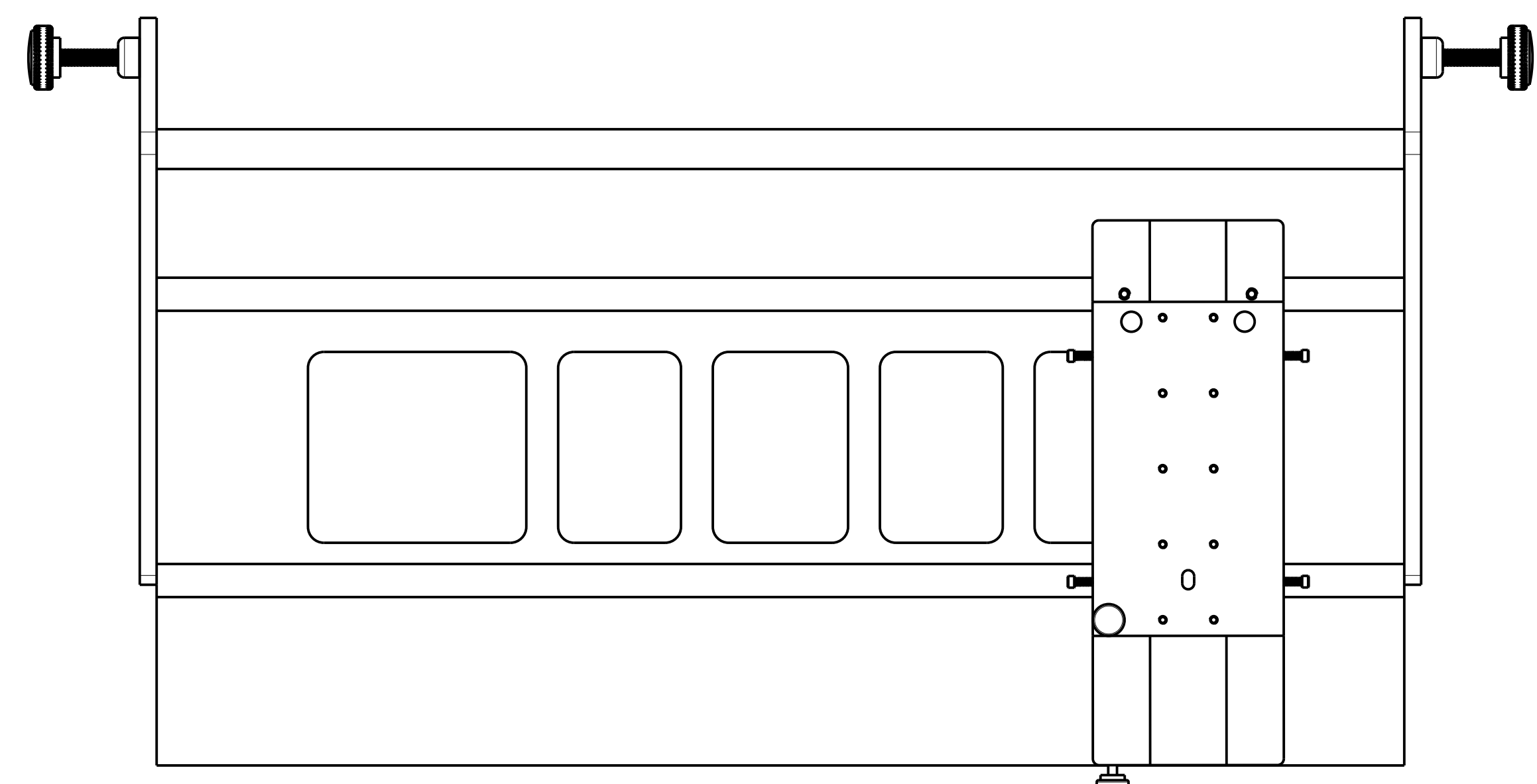

QTY	CAGE	PART NUMBER	DESCRIPTION	MATERIAL/SPECIFICATION/NOTES	ITEM
10			Ø12-24 UNC FLAT HEAD SCREW		6
4			LOCK KNOB		5
1		01910-431-300-000	ANALYZER MOUNT		4
1		01910-431-200-000	ANALYZER SLIDE CRADLE		3
1		01910-431-100-000	SLIDE PLATE WELDMENT		2
1		01910-431-000-001	SLIDE PLATE MOUNT	ANALYZER FIXTURE SIDE PLATE	1

DEFAULT TOLERANCES ONE PLACE (X.X) = ± 0.1 TWO PLACES (X.XX) = ± 0.01 THREE PLACES (X.XXX) = ± 0.005 FOUR PLACES (X.XXXX) = ± 0.0005 ANGLES = ± 0.5 DEGREE SURFACE FINISHES <= 125 MICROINCH RA		APPROVAL SIGNATURES DESIGNED BY: T. HUBY CHECKED BY: P. LANG DRAWN BY: LANG/CASTANO DATE: LANG/CASTANO DATE COMPLETION: DATE: FILE MODEL: ANALYZER_FIXTURE_MAIN		SOUTHWEST RESEARCH INSTITUTE OFFICE of AUTOMOTIVE ENGINEERING 6220 CULEBRA ROAD SAN ANTONIO, TEXAS 78238 ANALYZER FIXTURE MAIN ASSEMBLY	
THIRD ANGLE PROJECTION 		EXCEPT AS MAY OTHERWISE BE PROVIDED BY CONTRACT, THESE DIMENSIONS AND SPECIFICATIONS ARE THE PROPERTY OF SOUTHWEST RESEARCH INSTITUTE, ARE ISSUED IN STRICT CONFIDENCE, AND SHALL NOT BE REPRODUCED, OR COPIED, OR USED AS THE BASIS FOR MANUFACTURE OR SALE OF ANY APPARATUS SHOWN HEREON WITHOUT PERMISSION.		SCALE 1/2 UNIT WEIGHT = LBS SHEET 1 OF 1	

D
C
B
A

D
C
B
A

REVISIONS				
REV	SHT	ZONE	DESCRIPTION	DATE
A			INITIAL RELEASE	01 NOV 2013

GENERAL NOTES

- 1) DO NOT SCALE THIS DRAWING
- 2) UNLESS OTHERWISE STATED:
 - a. ALL DIMENSIONING AND TOLERANCING IS IN INCHES PER ASME Y14.5-2009
 - b. BREAK ALL SHARP CORNERS AND SHARP EDGES R .010 MAXIMUM
 - c. MACHINED SURFACE FINISHES SHALL BE 125 MICROINCH OR BETTER
 - d. TAP DRILL DEPTHS SHOWN ARE MAXIMUM
 - e. FULL THREAD DEPTHS SHOWN ARE MINIMUM
 - f. CHAMFER ALL TAPED HOLES TO (NOMINAL DIA + 1/16) x 90°
- 3) FINISH:

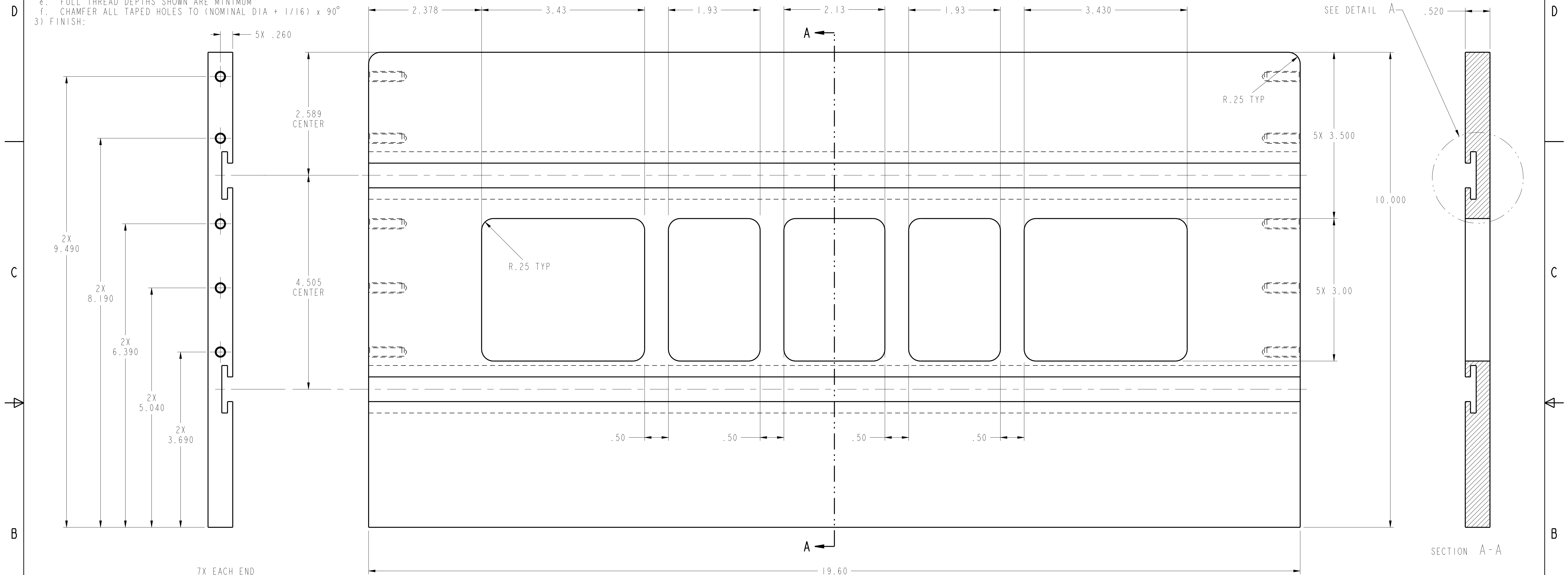

7X EACH END
 Ø12-24 UNC-2B TAP 0.85
 DRILL ⚭ 1.00

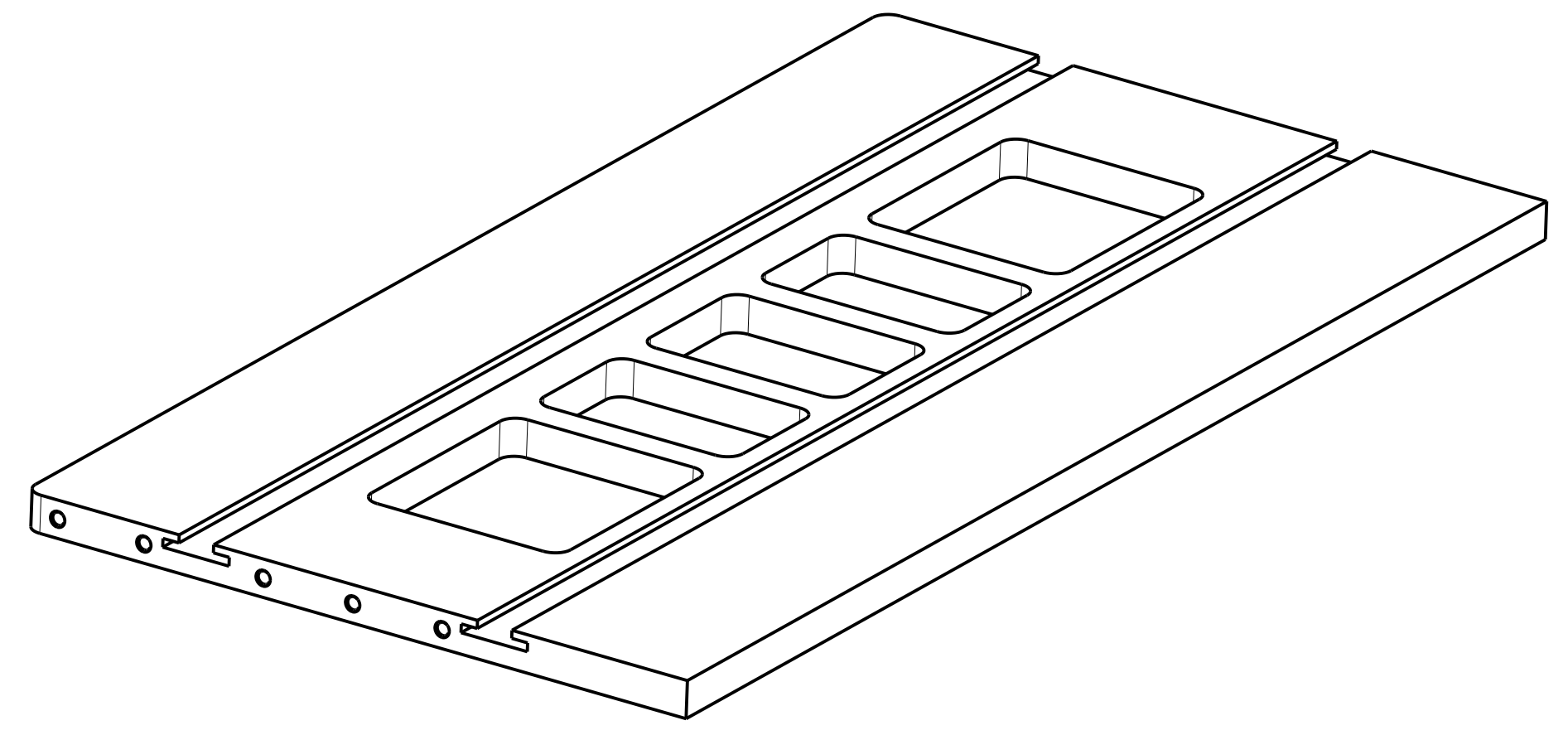
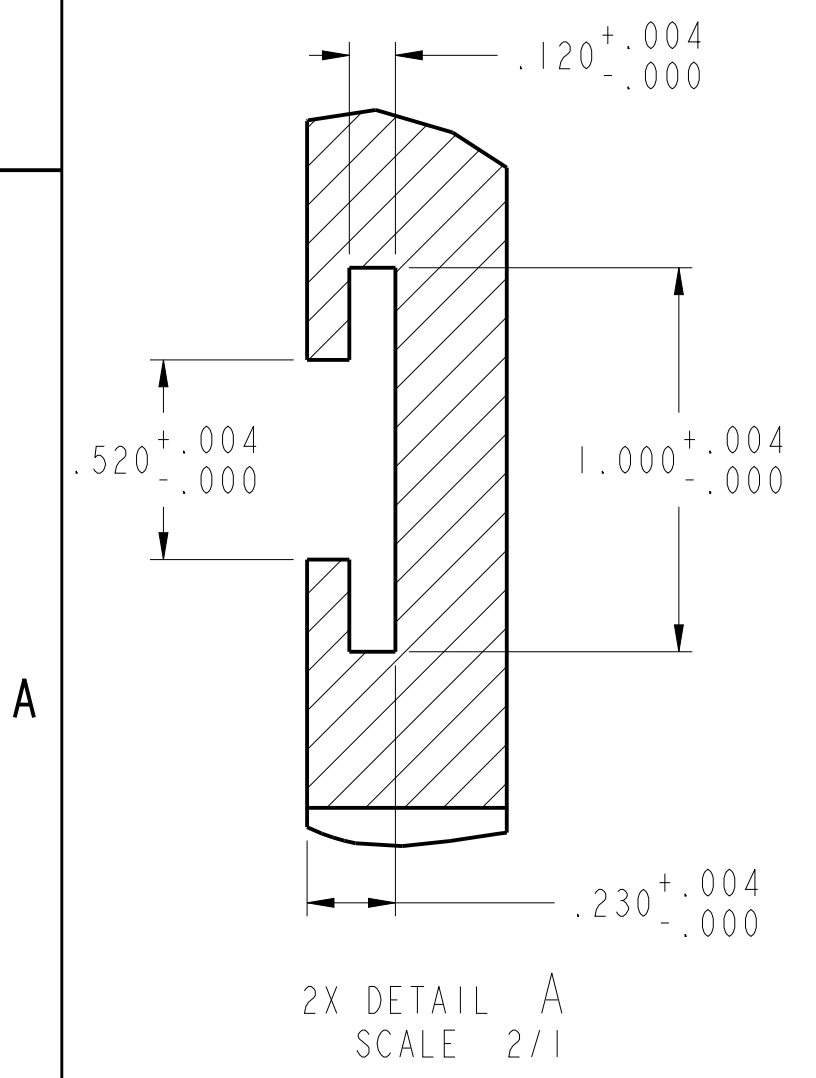

SCALE 1/2

		-1		6061-T6 ALUMINUM	I
-1	CAGE	PART NUMBER	DESCRIPTION	MATERIAL/SPECIFICATION/NOTES	ITEM
BILL OF MATERIAL/PARTS LIST					
DEFAULT TOLERANCES			APPROVAL SIGNATURES		
ONE PLACE (X.X) = ± 0.1			DESIGNER: T. HABY		
TWO PLACES (X.XX) = ± 0.01			CHECKER: LANG/CASTANO		
THREE PLACES (X.XXX) = ± 0.005			DRAWN: J. CASTANO		
FOUR PLACES (X.XXXX) = ± 0.0005			PROJ: P. LANG		
ANGLES = ± 0.5 DEGREE			DATE COMPLETION DATE:		
SURFACE FINISHES <= 125 MICROINCH RA			FILE MODEL: FIXTURE_SLIDE_PLATE		
THIRD ANGLE PROJECTION			EXCEPT AS MAY OTHERWISE BE PROVIDED BY CONTRACT, THESE DIMENSIONS AND SPECIFICATIONS ARE THE PROPERTY OF SOUTHWEST RESEARCH INSTITUTE, ARE ISSUED IN STRICT CONFIDENCE, AND SHALL NOT BE REPRODUCED, OR COPIED, OR USED AS THE BASIS FOR MANUFACTURE OR SALE OF ANY APPARATUS SHOWN THEREON WITHOUT PERMISSION.		
SHEET: D		CAGE: 26401		PART NUMBER: 01910-431-000-001	
SCALE: 1/1		UNIT WEIGHT: LBS		SHEET 1 OF 1	

SOUTHWEST RESEARCH INSTITUTE
 OFFICE of AUTOMOTIVE ENGINEERING
 6220 CULEBRA ROAD SAN ANTONIO, TEXAS 78238

FIXTURE SLIDE PLATE

REVISIONS				
REV	SHT	ZONE	DESCRIPTION	DATE
A			INITIAL RELEASE	01 NOV 2013

GENERAL NOTES

- 1) DO NOT SCALE THIS DRAWING
- 2) UNLESS OTHERWISE STATED:
 - a. ALL DIMENSIONING AND TOLERANCING IS IN INCHES PER ASME Y14.5-2009
 - b. BREAK ALL SHARP CORNERS AND SHARP EDGES R .010 MAXIMUM
 - c. MACHINED SURFACE FINISHES SHALL BE 125 MICROINCH OR BETTER
 - d. TAP DRILL DEPTHS SHOWN ARE MAXIMUM
 - e. FULL THREAD DEPTHS SHOWN ARE MINIMUM
 - f. CHAMFER ALL TAPED HOLES TO (NOMINAL DIA + 1/16) x 90°
- 3) FINISH:

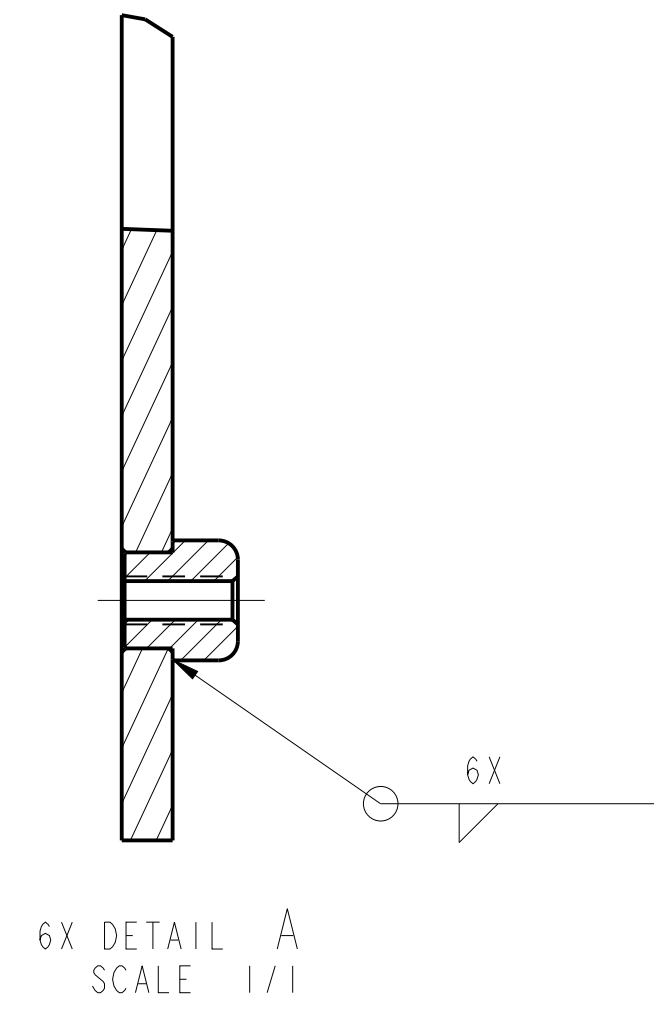
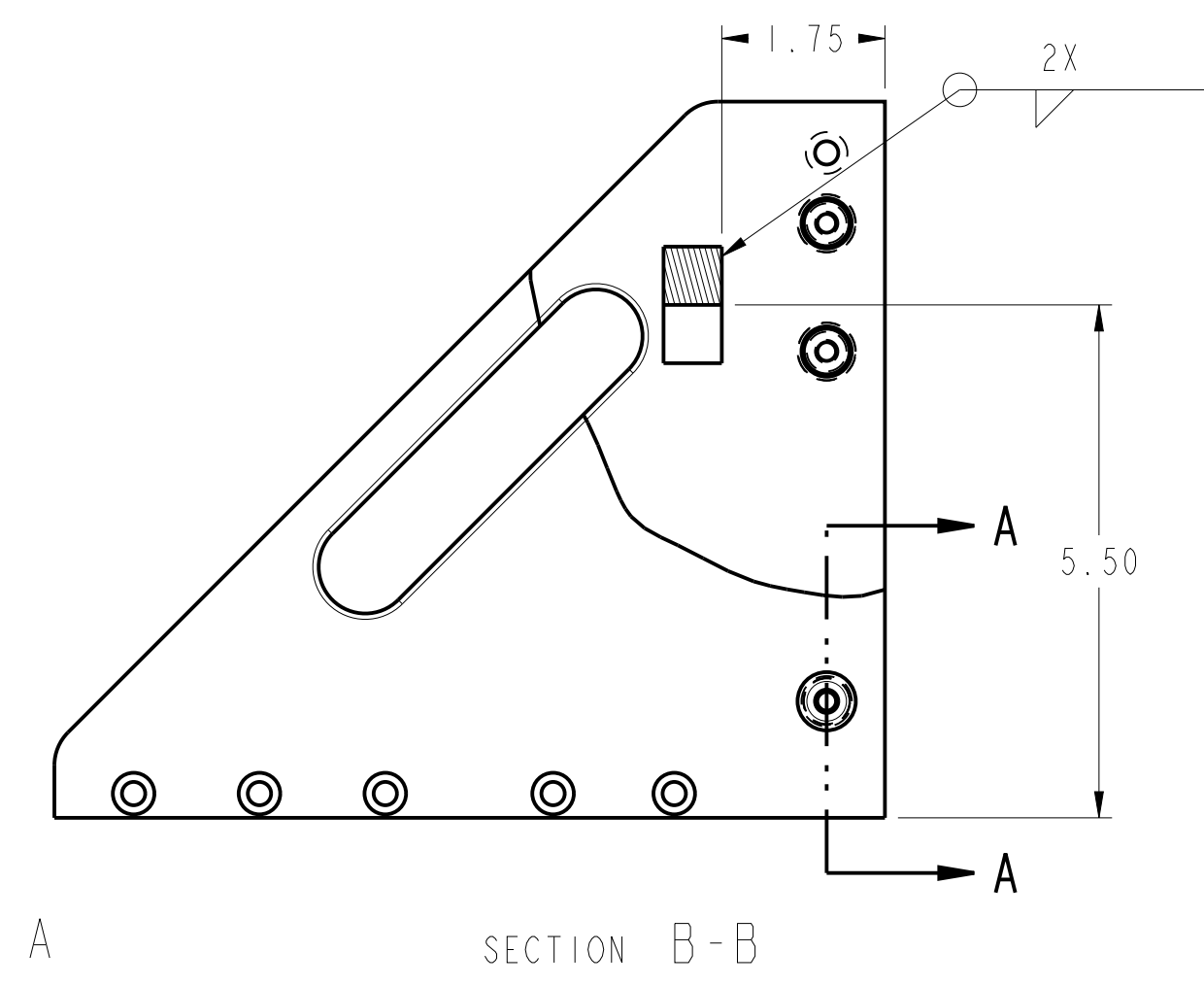
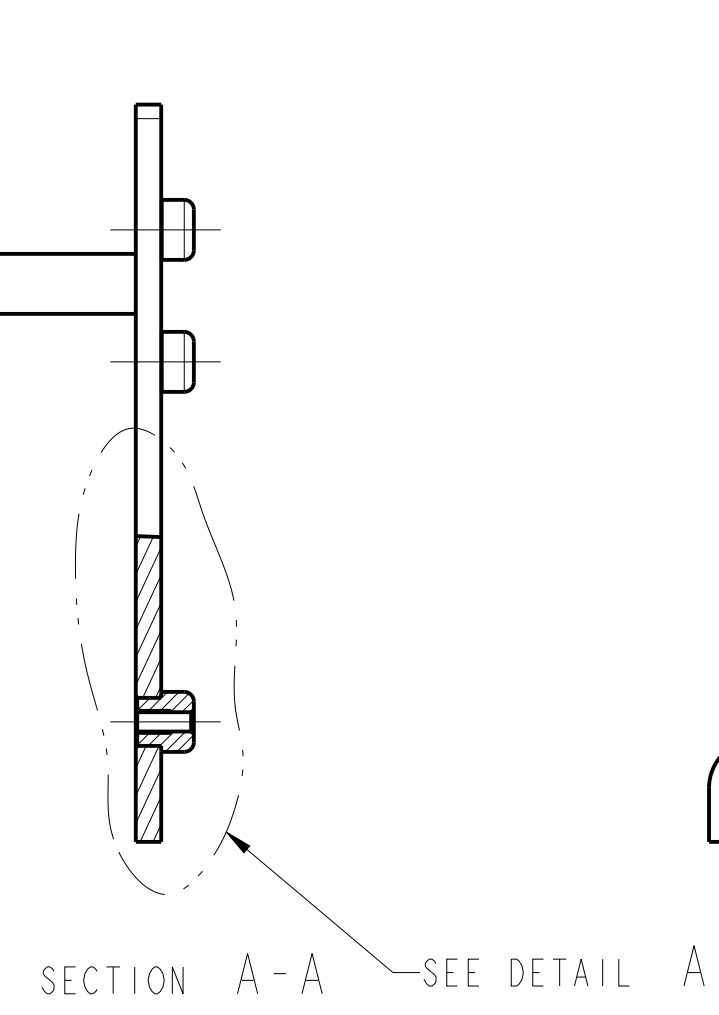
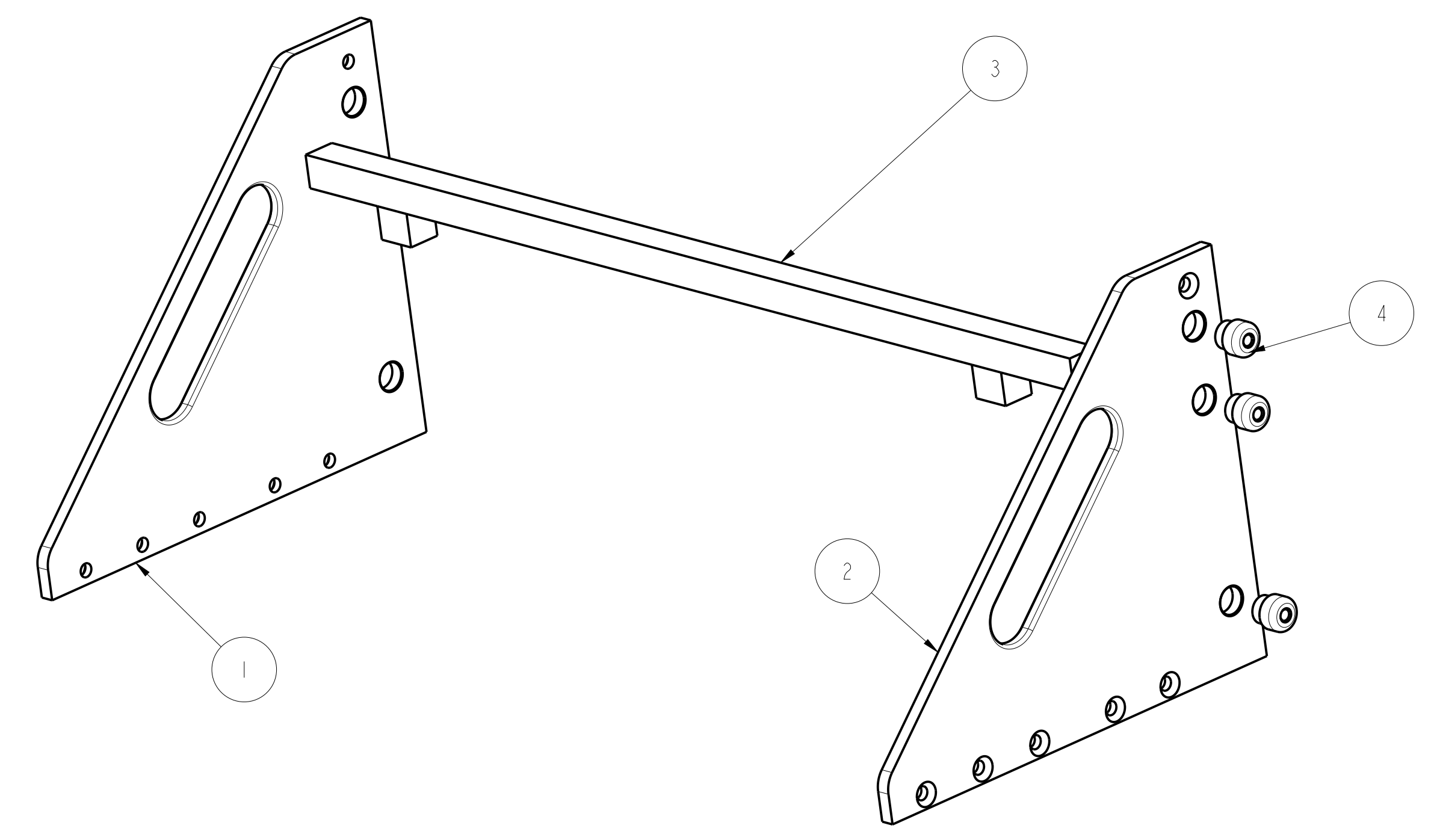
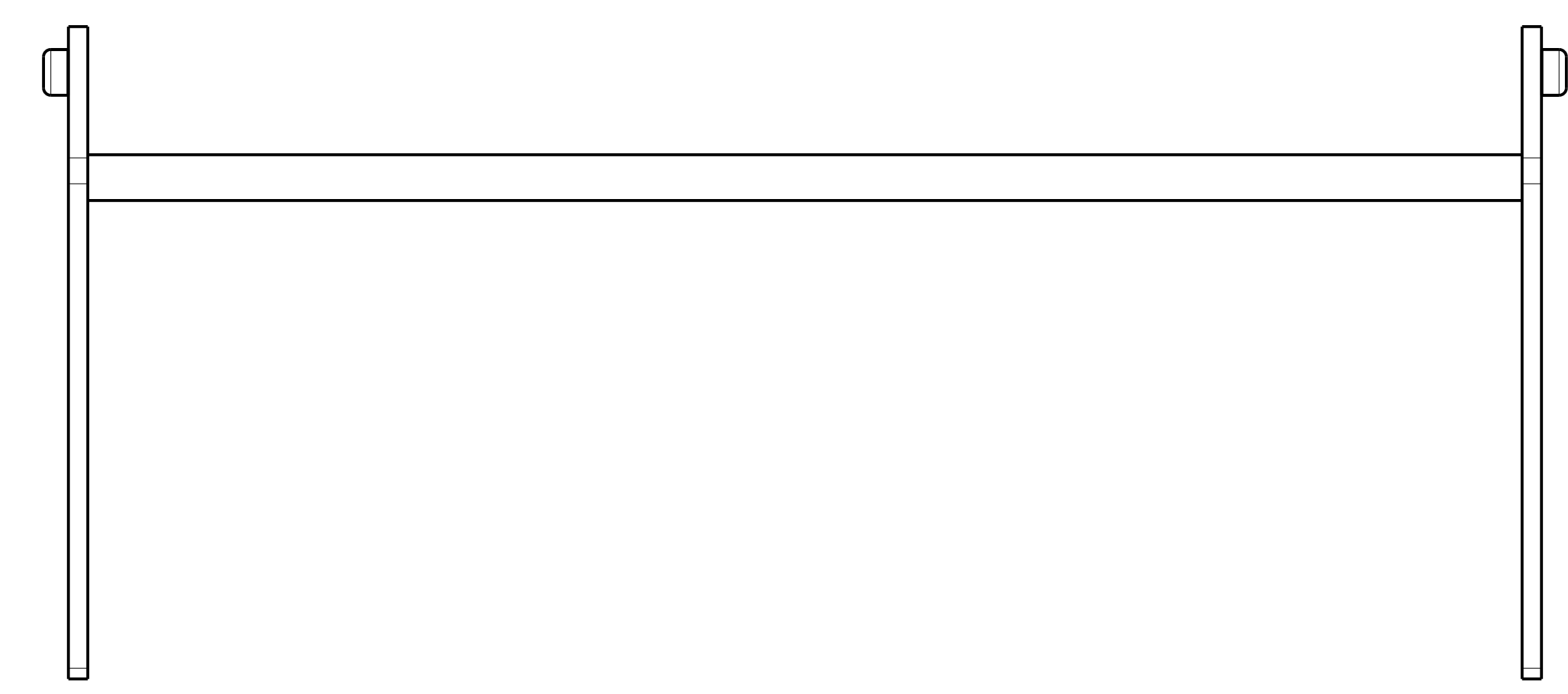

QTY	CAGE	PART NUMBER	DESCRIPTION	MATERIAL/SPECIFICATION/NOTES	ITEM
6		01910-431-100-004	SIDE PLATE BOSS		4
1		01910-431-100-003	SIDE PLATE SPACER BAR		3
1		01910-431-100-002	SIDE PLATE RIGHT		2
1		01910-431-100-001	SIDE PLATE LEFT		1

BILL OF MATERIAL/PARTS LIST			
DEFAULT TOLERANCES		APPROVAL SIGNATURES	
ONE PLACE (X.X) = ± 0.1	DESIGNER: T. HABY	APPROVED: _____	
TWO PLACES (X.XX) = ± 0.01	CHK: P. LANG	DATE: _____	
THREE PLACES (X.XXX) = ± 0.005	DRG: LANG/CASTNO	COMPLETION DATE: _____	
FOUR PLACES (X.XXXX) = ± 0.0005	PROJ: LANG/CASTNO	FILE: _____	
ANGLES = ± 0.5 DEGREE	DATE: _____	MODEL: SIDE_PLATE_WELDMNT	
SURFACE FINISHES <= 125 MICROINCH RA	THIRD ANGLE PROJECTION	EXCEPT AS MAY OTHERWISE BE PROVIDED BY CONTRACT, THESE DRAWINGS AND SPECIFICATIONS ARE THE PROPERTY OF SOUTHWEST RESEARCH INSTITUTE, ARE ISSUED IN STRICT CONFIDENCE, AND SHALL NOT BE REPRODUCED, OR COPIED, OR USED AS THE BASIS FOR MANUFACTURE OR SALE OF ANY APPARATUS SHOWN THEREON WITHOUT PERMISSION.	
SOUTHWEST RESEARCH INSTITUTE OFFICE of AUTOMOTIVE ENGINEERING 6220 CULEBRA ROAD SAN ANTONIO, TEXAS 78238		ANALYZER SIDE PLATE WELDMNT	
SCALE 1/2	UNIT WEIGHT = LBS	SHEET 1 OF 1	

REVISIONS				
REV	SHT	ZONE	DESCRIPTION	DATE
A			INITIAL RELEASE	01 NOV 2013

GENERAL NOTES

- 1) DO NOT SCALE THIS DRAWING
- 2) UNLESS OTHERWISE STATED:
 - a. ALL DIMENSIONING AND TOLERANCING IS IN INCHES PER ASME Y14.5-2009
 - b. BREAK ALL SHARP CORNERS AND SHARP EDGES R .010 MAXIMUM
 - c. MACHINED SURFACE FINISHES SHALL BE 125 MICROINCH OR BETTER
 - d. TAP DRILL DEPTHS SHOWN ARE MAXIMUM
 - e. FULL THREAD DEPTHS SHOWN ARE MINIMUM
 - f. CHAMFER ALL TAPED HOLES TO (NOMINAL DIA + 1/16) x 90°
- 3) FINISH:

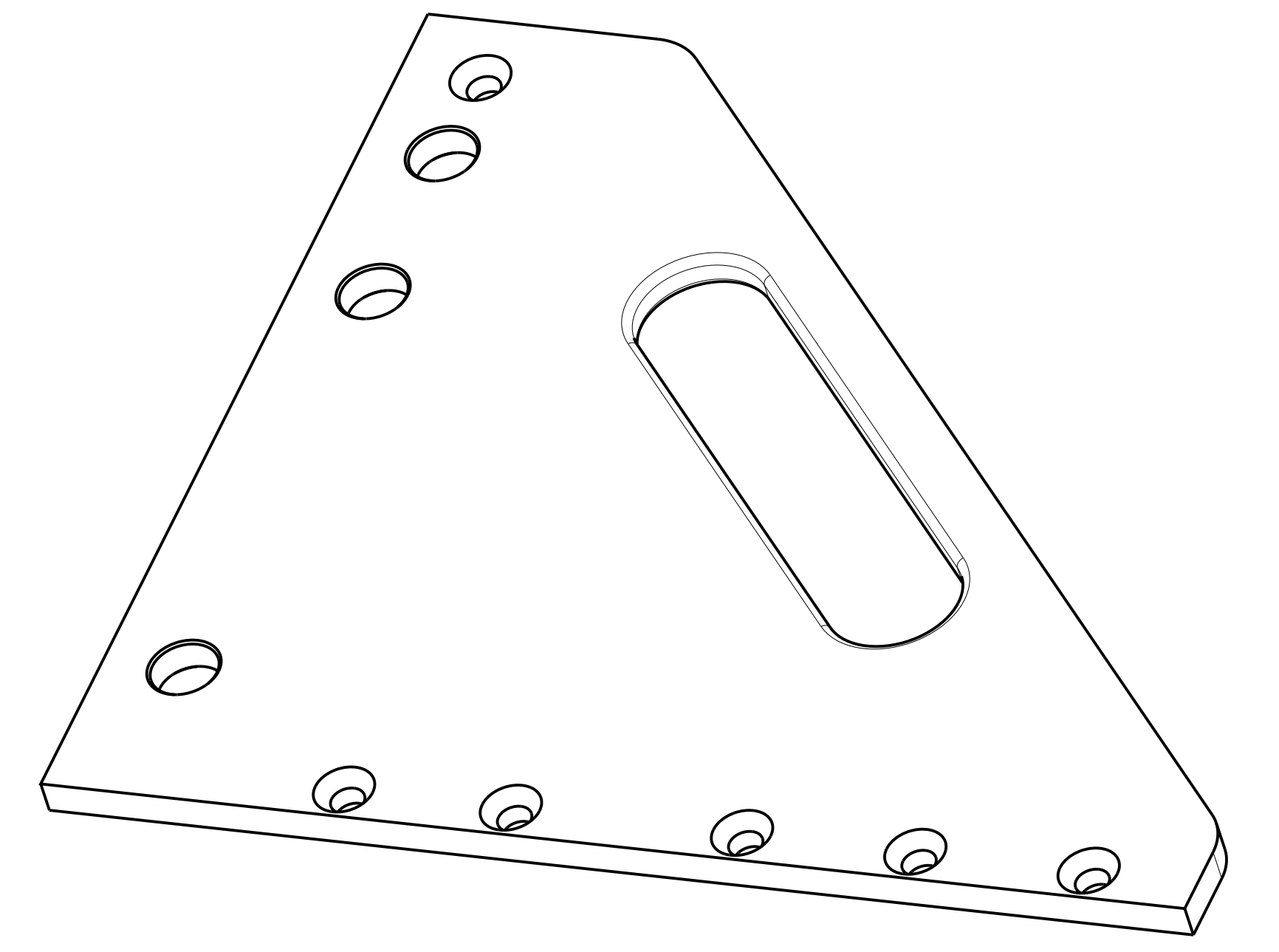
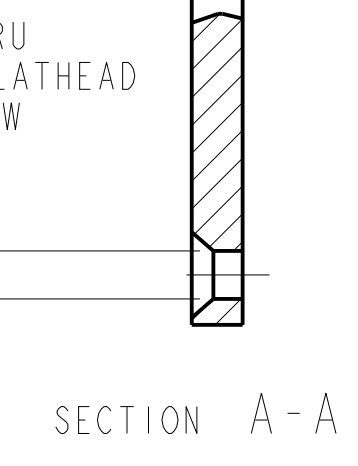
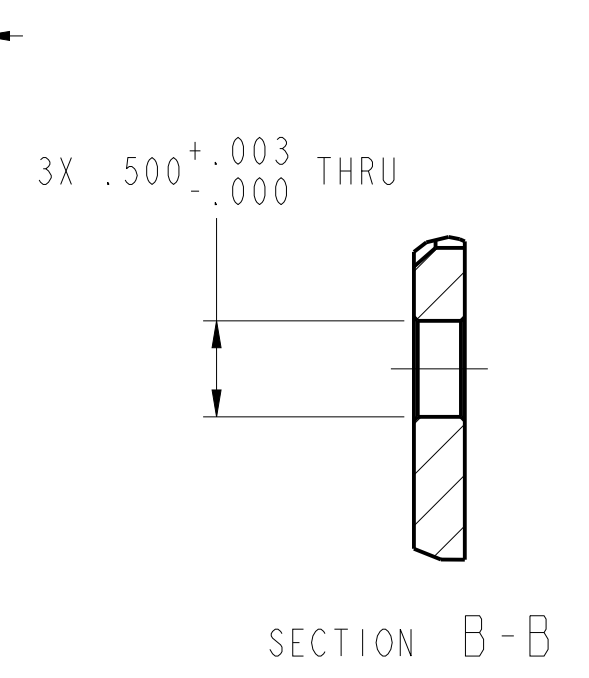
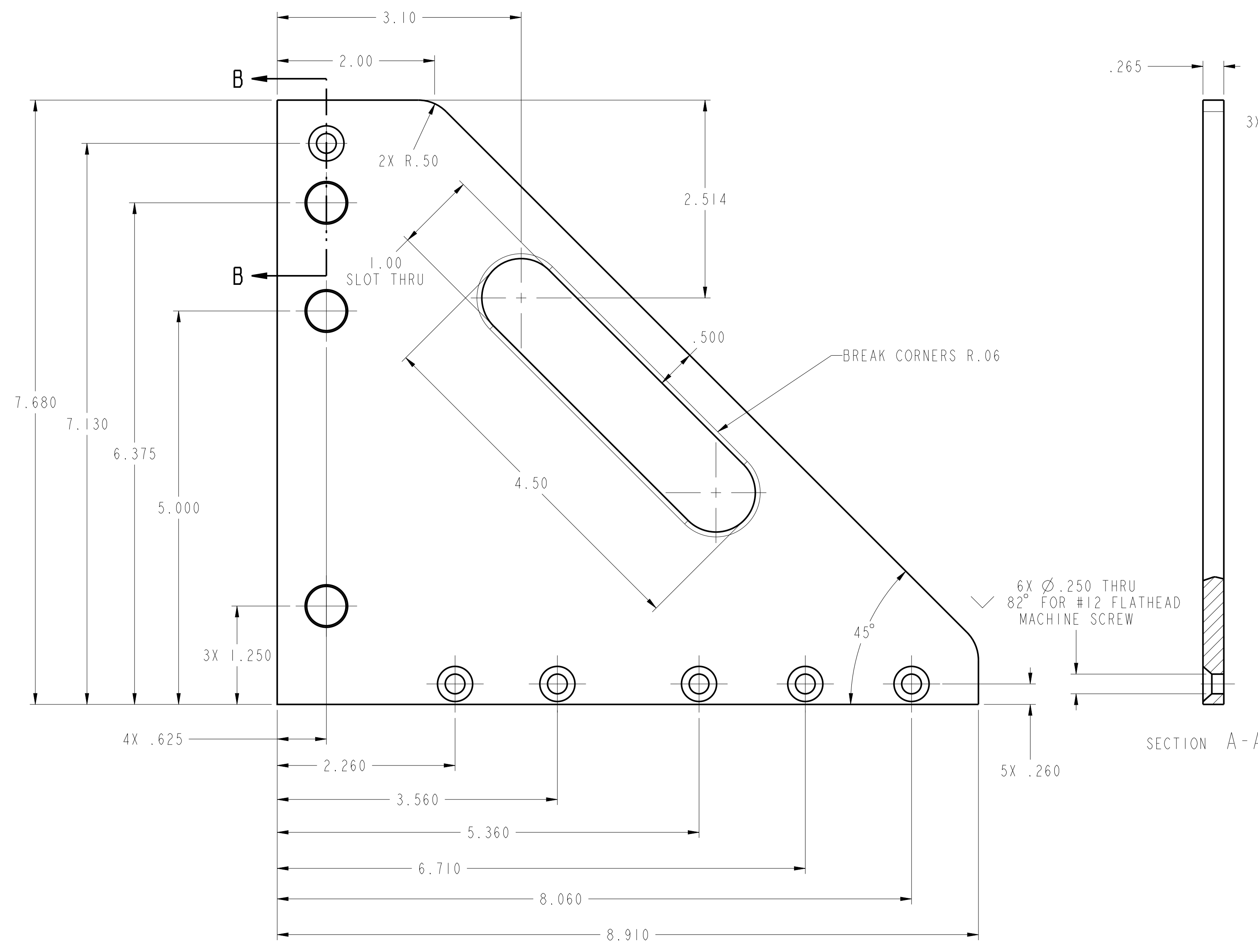

-1	-1	SIDE PLATE	6061-T6 ALUMINUM	I
-1	CAGE	PART NUMBER	DESCRIPTION	MATERIAL/SPECIFICATION/NOTES
BILL OF MATERIAL/PARTS LIST				
DEFAULT TOLERANCES		APPROVAL SIGNATURES		
ONE PLACE (X.X) = ± 0.1	DESIGNER: T. HABY			
TWO PLACES (X.XX) = ± 0.01	CHK: P. LANG			
THREE PLACES (X.XXX) = ± 0.005	APP: LANG/CASTANO			
FOUR PLACES (X.XXXX) = ± 0.0005	PROJ: LANG/CASTANO			
ANGLES = ± 0.5 DEGREE	DATE COMPLETION DATE:			
SURFACE FINISHES <= 125 MICROINCH RA	FILE MODEL: SIDE.BRACE.LEFT			
THIRD ANGLE PROJECTION		EXCEPT AS MAY OTHERWISE BE PROVIDED BY CONTRACT, THESE DIMENSIONS AND SPECIFICATIONS ARE THE PROPERTY OF SOUTHWEST RESEARCH INSTITUTE, ARE ISSUED IN STRICT CONFIDENCE, AND SHALL NOT BE REPRODUCED, OR COPIED, OR USED AS THE BASIS FOR MANUFACTURE OR SALE OF ANY APPARATUS SHOWN THEREON WITHOUT PERMISSION.		
		SOUTHWEST RESEARCH INSTITUTE OFFICE of AUTOMOTIVE ENGINEERING 6220 CULEBRA ROAD SAN ANTONIO, TEXAS 78238		
		SIDE PLATE, LEFT		
D	26401	01910-431-100-001	A	
SCALE 1/1		UNIT WEIGHT = LBS	SHEET 1 OF 1	

REVISIONS				
REV	SHT	ZONE	DESCRIPTION	DATE
A			INITIAL RELEASE	01 NOV 2013

GENERAL NOTES

- 1) DO NOT SCALE THIS DRAWING
- 2) UNLESS OTHERWISE STATED:
 - a. ALL DIMENSIONING AND TOLERANCING IS IN INCHES PER ASME Y14.5-2009
 - b. BREAK ALL SHARP CORNERS AND SHARP EDGES R .010 MAXIMUM
 - c. MACHINED SURFACE FINISHES SHALL BE 125 MICROINCH OR BETTER
 - d. TAP DRILL DEPTHS SHOWN ARE MAXIMUM
 - e. FULL THREAD DEPTHS SHOWN ARE MINIMUM
 - f. CHAMFER ALL TAPED HOLES TO (NOMINAL DIA + 1/16) x 90°
- 3) FINISH:

D
C
B
A

D
C
B
A

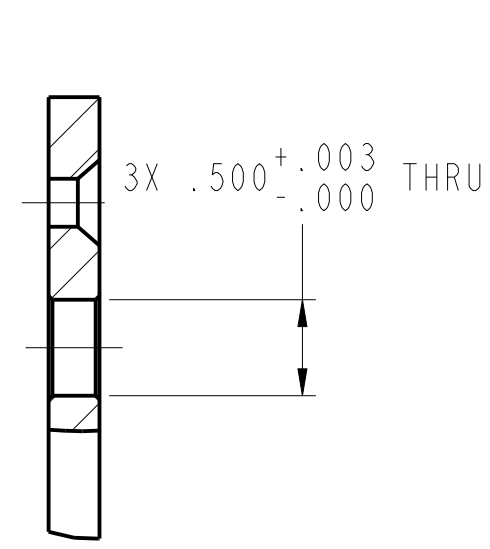

SECTION B-B

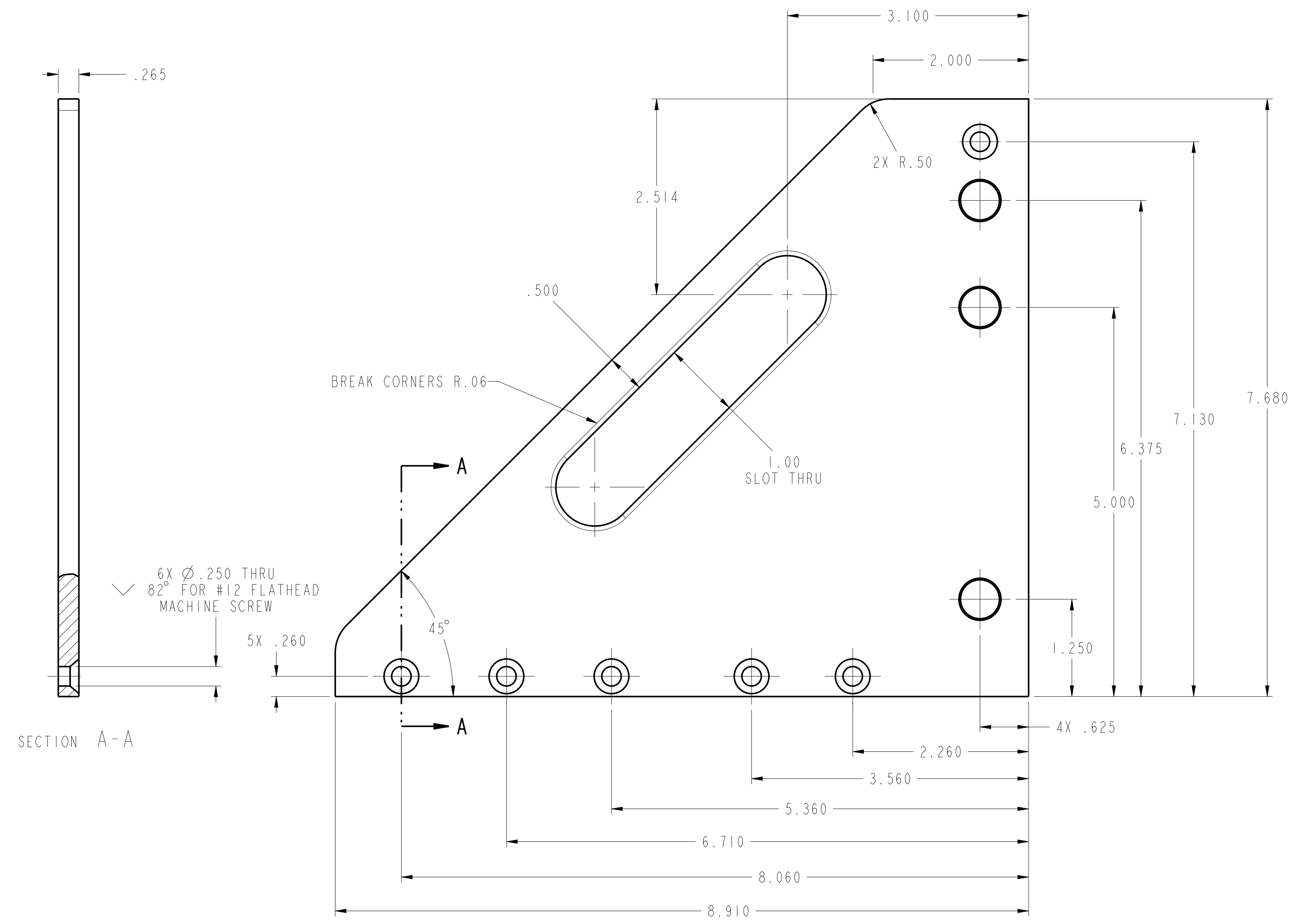

SECTION A-A

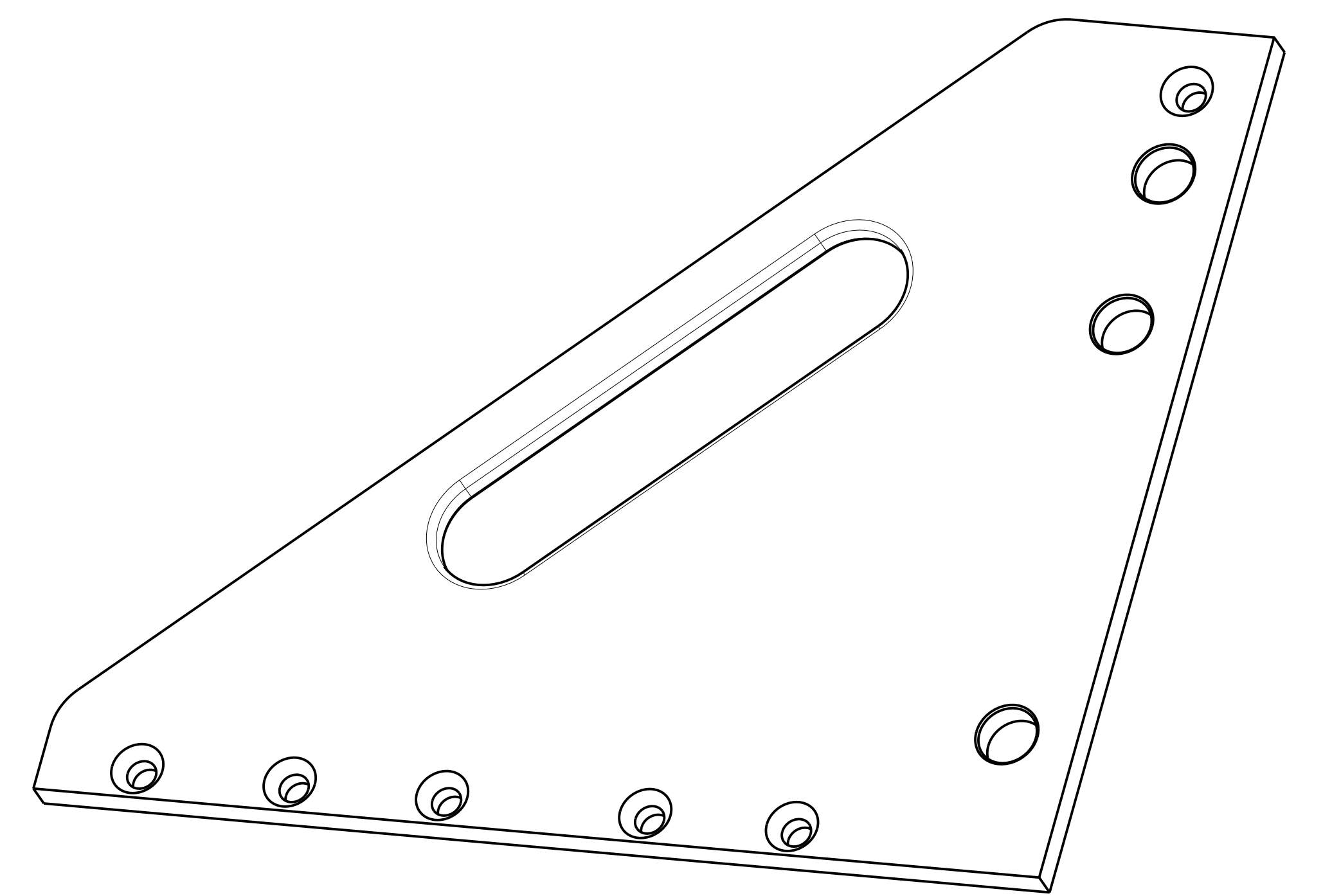

-1	CAGE	-1	SIDE PLATE	6061-T6 ALUMINUM	1
-1	PART NUMBER		DESCRIPTION	MATERIAL/SPECIFICATION/NOTES	ITEM
BILL OF MATERIAL/PARTS LIST					
DEFAULT TOLERANCES			APPROVAL SIGNATURES		
ONE PLACE (X.X) = ± 0.1	PART HADY		<p>SOUTHWEST RESEARCH INSTITUTE OFFICE of AUTOMOTIVE ENGINEERING 6220 CULEBRA ROAD SAN ANTONIO, TEXAS 78238</p> <p style="text-align: center; font-size: 1.2em;">SIDE PLATE RIGHT</p>		
TWO PLACES (X.XX) = ± 0.01	CWP P LANG				
THREE PLACES (X.XXX) = ± 0.005	DGG LANG/CASTANO				
FOUR PLACES (X.XXXX) = ± 0.0005	PRL LANG/CASTANO				
ANGLES = ± 0.5 DEGREE	DATE COMPLETION DATE:				
SURFACE FINISHES <= 125 MICROINCH RA	FILE MODEL: SIDE_PLATE_RIGHT		<p>EXCEPT AS MAY OTHERWISE BE PROVIDED BY CONTRACT, THESE DIMENSIONS AND SPECIFICATIONS ARE THE PROPERTY OF SOUTHWEST RESEARCH INSTITUTE, ARE ISSUED IN STRICT CONFIDENCE, AND SHALL NOT BE REPRODUCED, OR COPIED, OR USED AS THE BASIS FOR MANUFACTURE OR SALE OF ANY APPARATUS SHOWN HEREON WITHOUT PERMISSION.</p>		
THIRD ANGLE PROJECTION					
SCALE 1/1		UNIT WEIGHT = LBS		SHEET 1 OF 1	

REVISIONS				
REV	SHT	ZONE	DESCRIPTION	DATE
A			INITIAL RELEASE	01 NOV 2013

GENERAL NOTES

- 1) DO NOT SCALE THIS DRAWING
- 2) UNLESS OTHERWISE STATED:
 - a. ALL DIMENSIONING AND TOLERANCING IS IN INCHES PER ASME Y14.5-2009
 - b. BREAK ALL SHARP CORNERS AND SHARP EDGES R .010 MAXIMUM
 - c. MACHINED SURFACE FINISHES SHALL BE 125 MICROINCH OR BETTER
 - d. TAP DRILL DEPTHS SHOWN ARE MAXIMUM
 - e. FULL THREAD DEPTHS SHOWN ARE MINIMUM
 - f. CHAMFER ALL TAPED HOLES TO (NOMINAL DIA + 1/16) x 90°
- 3) FINISH:

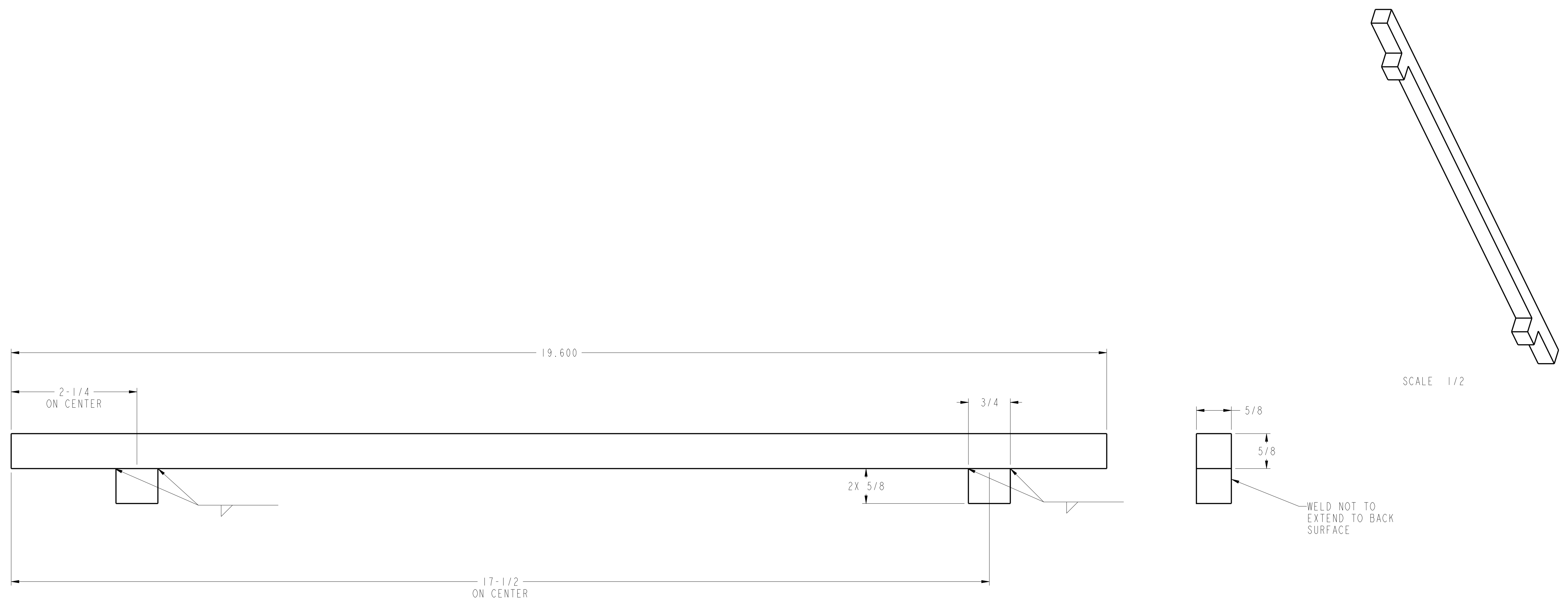

-1	CAGE	-1	SPACER BAR	6061-T6 ALUMINUM	1
-1	PART NUMBER		DESCRIPTION	MATERIAL/SPECIFICATION/NOTES	ITEM
BILL OF MATERIAL/PARTS LIST					
DEFAULT TOLERANCES			APPROVAL SIGNATURES		
ONE PLACE (X.X) = ± 0.1	DESIGNER		APPROVED		
TWO PLACES (X.XX) = ± 0.01	CHECKER		DATE		
THREE PLACES (X.XXX) = ± 0.005	DRAWN		COMPLETION DATE:		
FOUR PLACES (X.XXXX) = ± 0.0005	PROJ		MODEL: SIDE_PLATE_CROSS_BAR		
ANGLES = ± 0.5 DEGREE	DATE		THIRD ANGLE PROJECTION		
SURFACE FINISHES <= 125 MICROINCH RA	FILE		EXCEPT AS MAY OTHERWISE BE PROVIDED BY CONTRACT, THESE DRAWINGS AND SPECIFICATIONS ARE THE PROPERTY OF SOUTHWEST RESEARCH INSTITUTE, ARE ISSUED IN STRICT CONFIDENCE, AND SHALL NOT BE REPRODUCED, OR COPIED, OR USED AS THE BASIS FOR MANUFACTURE OR SALE OF ANY APPARATUS SHOWN THEREON WITHOUT PERMISSION		
SOUTHWEST RESEARCH INSTITUTE		OFFICE of AUTOMOTIVE ENGINEERING			
6220 CULEBRA ROAD		SAN ANTONIO, TEXAS 78238			
SIDE PLATE SPACER BAR					
D	26401	01910-431-100-003	A	SCALE 1/1 UNIT WEIGHT = LBS SHEET 1 OF 1	

REVISIONS				
REV	SHT	ZONE	DESCRIPTION	DATE
A			INITIAL RELEASE	01 NOV 2013

GENERAL NOTES

- 1) DO NOT SCALE THIS DRAWING
- 2) UNLESS OTHERWISE STATED:
 - a. ALL DIMENSIONING AND TOLERANCING IS IN INCHES PER ASME Y14.5-2009
 - b. BREAK ALL SHARP CORNERS AND SHARP EDGES R .010 MAXIMUM
 - c. MACHINED SURFACE FINISHES SHALL BE 125 MICROINCH OR BETTER
 - d. TAP DRILL DEPTHS SHOWN ARE MAXIMUM
 - e. FULL THREAD DEPTHS SHOWN ARE MINIMUM
 - f. CHAMFER ALL TAPED HOLES TO (NOMINAL DIA + 1/16) x 90°
- 3) FINISH:

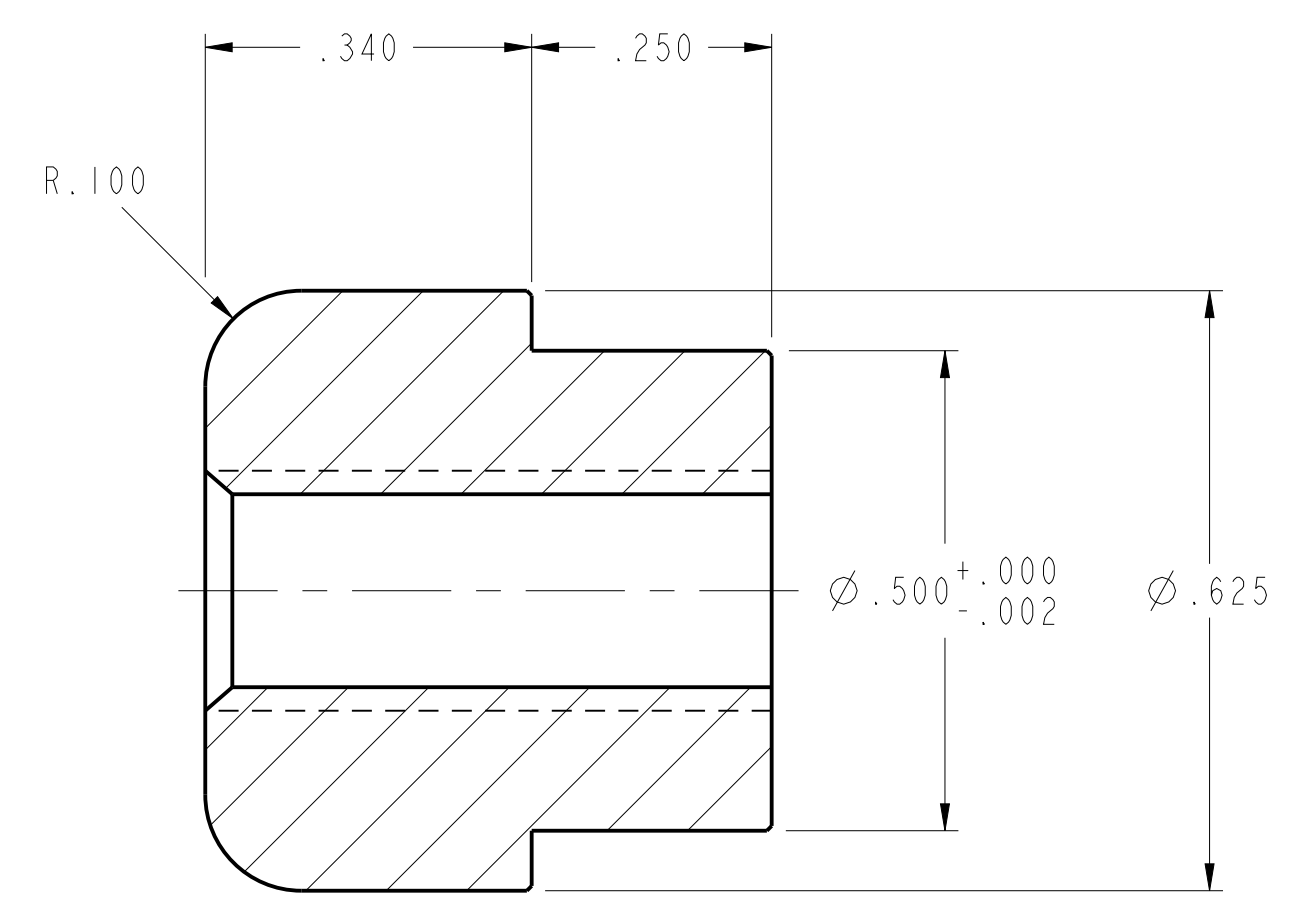
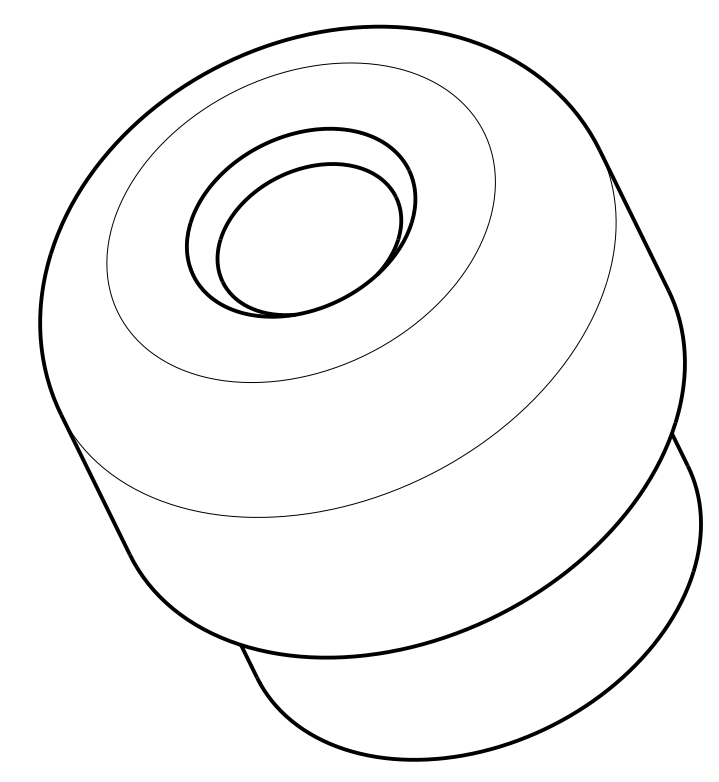

SECTION A-A

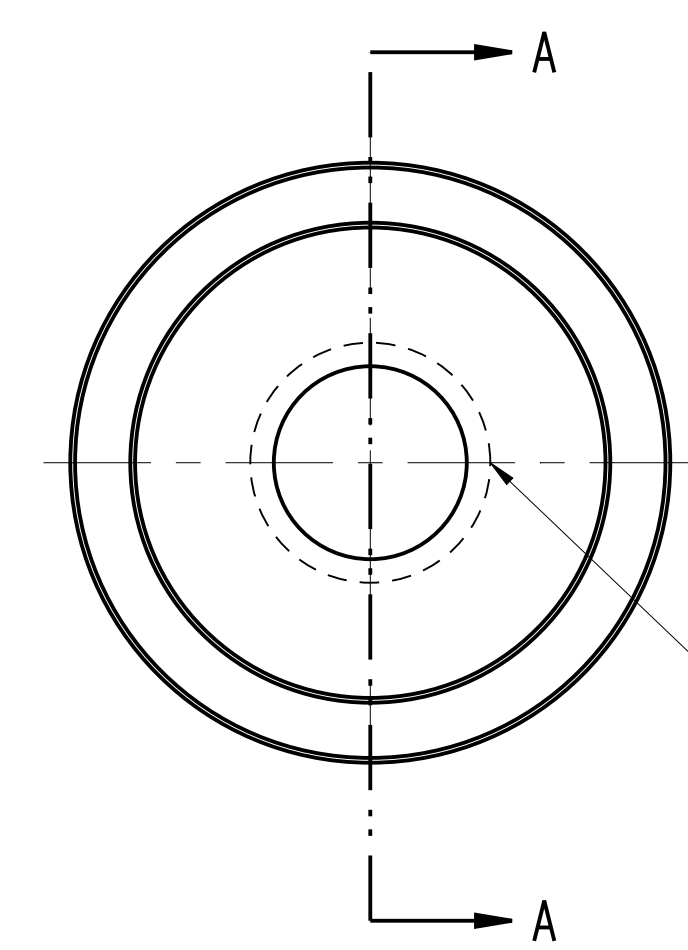

1/4-20 UNC - 2B TAP THRU
#7 DRILL (0.201) THRU - (1) HOLE

-1	CAGE	-1	BOSS	6061 ALUMINUM	1
-1	CAGE	PART NUMBER	DESCRIPTION	MATERIAL/SPECIFICATION/NOTES	ITEM
BILL OF MATERIAL/PARTS LIST					
DEFAULT TOLERANCES			APPROVAL SIGNATURES		
ONE PLACE (X.X) = ± 0.1	DESIGNER: T. HABY		SOUTHWEST RESEARCH INSTITUTE OFFICE of AUTOMOTIVE ENGINEERING 6220 CULEBRA ROAD SAN ANTONIO, TEXAS 78238		
TWO PLACES (X.XX) = ± 0.01	CHECKER: P. LANG				
THREE PLACES (X.XXX) = ± 0.005	DESIGNER: LANG/CASTANO				
FOUR PLACES (X.XXXX) = ± 0.0005	DESIGNER: LANG/CASTANO				
ANGLES = ± 0.5 DEGREE	DATE COMPLETION DATE:		SIDE PLATE WELDMENT BOSS SCALE 5/1 UNIT WEIGHT = LBS SHEET 1 OF 1		
SURFACE FINISHES <= 125 MICROINCH RA	FILE MODEL: SIDE_PLATE_SCREW_BOSS				
THIRD ANGLE PROJECTION			EXCEPT AS MAY OTHERWISE BE PROVIDED BY CONTRACT, THESE DRAWINGS AND SPECIFICATIONS ARE THE PROPERTY OF SOUTHWEST RESEARCH INSTITUTE, ARE ISSUED IN STRICT CONFIDENCE, AND SHALL NOT BE REPRODUCED, OR COPIED, OR USED AS THE BASIS FOR MANUFACTURE OR SALE OF ANY APPARATUS SHOWN HEREON WITHOUT PERMISSION.		
			PART NUMBER: D 26401 DRAWING NUMBER: 01910-431-100-004 REV: A		

REVISIONS				
REV	SHT	ZONE	DESCRIPTION	DATE
A			INITIAL RELEASE	01 NOV 2013

GENERAL NOTES

- 1) DO NOT SCALE THIS DRAWING
- 2) UNLESS OTHERWISE STATED:
 - a. ALL DIMENSIONING AND TOLERANCING IS IN INCHES PER ASME Y14.5-2009
 - b. BREAK ALL SHARP CORNERS AND SHARP EDGES R .010 MAXIMUM
 - c. MACHINED SURFACE FINISHES SHALL BE 125 MICROINCH OR BETTER
 - d. TAP DRILL DEPTHS SHOWN ARE MAXIMUM
 - e. FULL THREAD DEPTHS SHOWN ARE MINIMUM
 - f. CHAMFER ALL TAPED HOLES TO (NOMINAL DIA + 1/16) x 90°
- 3) FINISH:

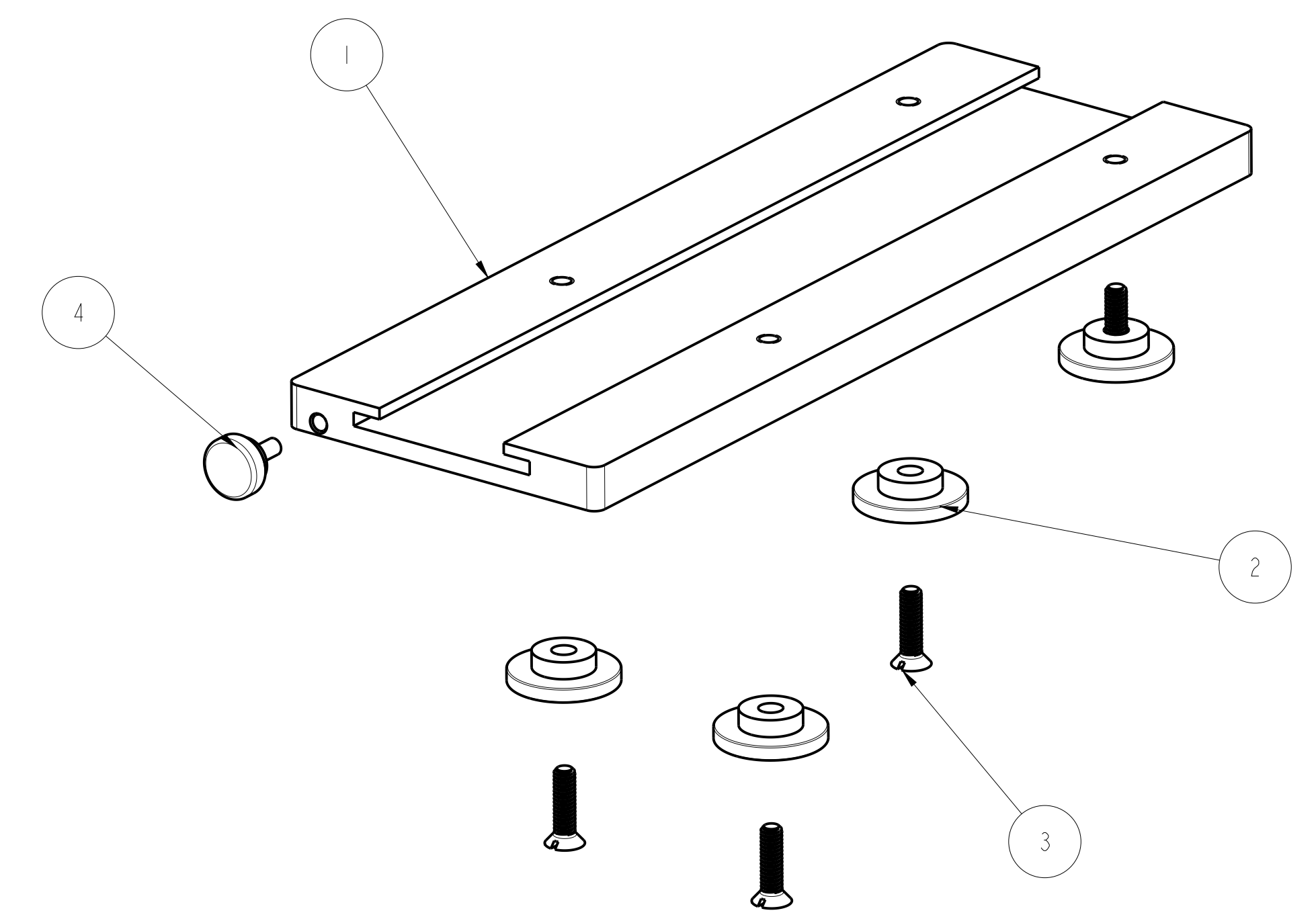
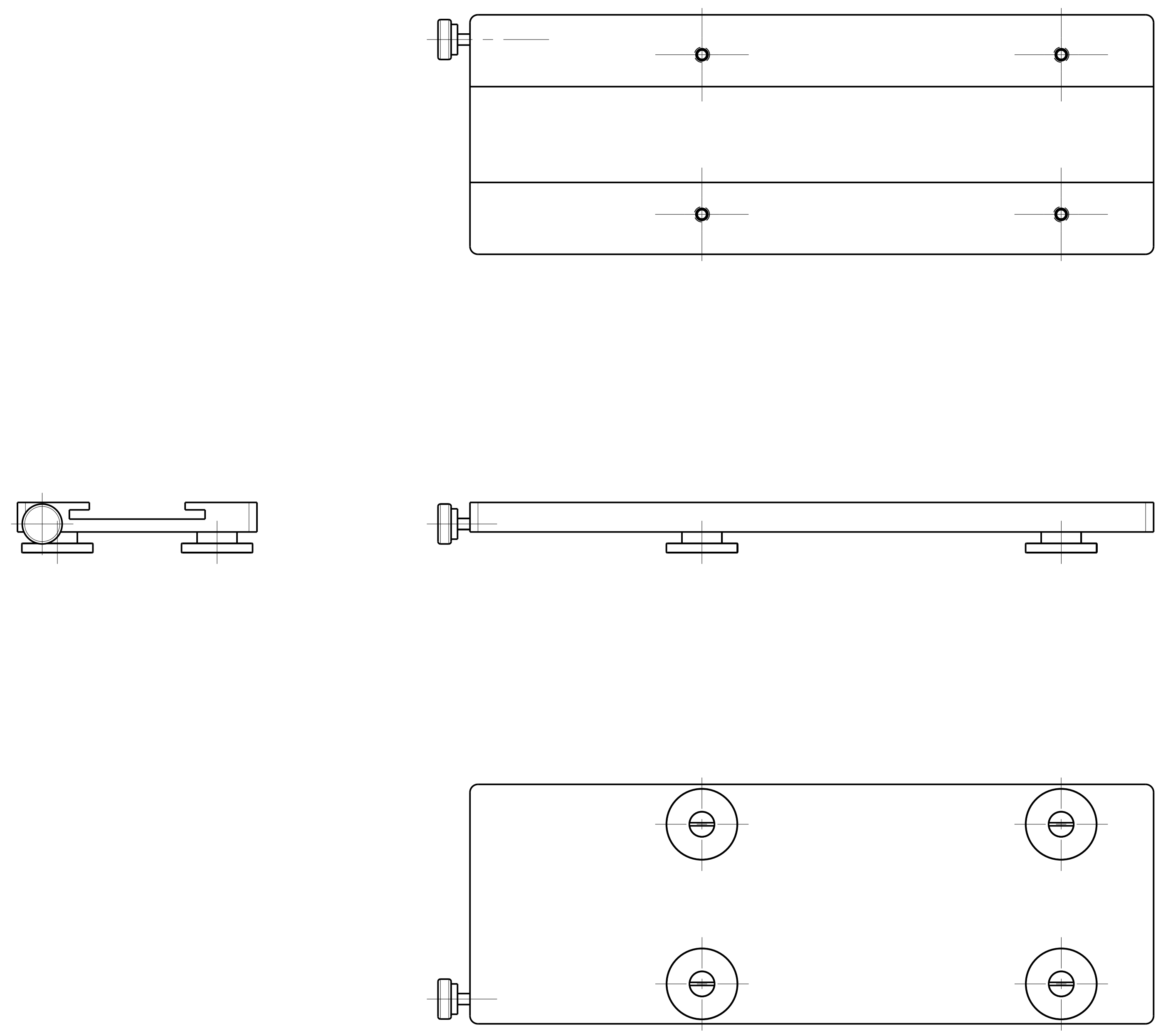

QTY	CAGE	PART NUMBER	DESCRIPTION	MATERIAL/SPECIFICATION/NOTES	ITEM
1			6-32 THREADED KNOB		4
4			8-32 X 5/8 FLAT HEAD SCREW		3
4		01910-431-200-002	SLIDE DISC		2
1		01910-431-200-001	SLIDE CRADLE		1

DEFAULT TOLERANCES ONE PLACE (X.X) = ± 0.1 TWO PLACES (X.XX) = ± 0.01 THREE PLACES (X.XXX) = ± 0.005 FOUR PLACES (X.XXXX) = ± 0.0005 ANGLES = ± 0.5 DEGREE SURFACE FINISHES <= 125 MICROINCH RA		APPROVAL SIGNATURES DESIGNED BY: P. LANG DRAWN BY: P. LANG/CASTANO DATE COMPLETION: [] FILE MODEL: ANALYZER_CRADLE		SOUTHWEST RESEARCH INSTITUTE OFFICE of AUTOMOTIVE ENGINEERING 6220 CULEBRA ROAD SAN ANTONIO, TEXAS 78238 ANALYZER SLIDE CRADLE	
THIRD ANGLE PROJECTION 		EXCEPT AS MAY OTHERWISE BE PROVIDED BY CONTRACT, THESE DRAWINGS AND SPECIFICATIONS ARE THE PROPERTY OF SOUTHWEST RESEARCH INSTITUTE, ARE ISSUED IN STRICT CONFIDENCE, AND SHALL NOT BE REPRODUCED, OR COPIED, OR USED AS THE BASIS FOR MANUFACTURE OR SALE OF ANY APPARATUS SHOWN HEREON WITHOUT PERMISSION.		SCALE 1/1 UNIT WEIGHT = LBS SHEET 1 OF 1	

REVISIONS				
REV	SHT	ZONE	DESCRIPTION	DATE
A			INITIAL RELEASE	01 NOV 2013

GENERAL NOTES

- 1) DO NOT SCALE THIS DRAWING
- 2) UNLESS OTHERWISE STATED:
 - a. ALL DIMENSIONING AND TOLERANCING IS IN INCHES PER ASME Y14.5-2009
 - b. BREAK ALL SHARP CORNERS AND SHARP EDGES R .010 MAXIMUM
 - c. MACHINED SURFACE FINISHES SHALL BE 125 MICROINCH OR BETTER
 - d. TAP DRILL DEPTHS SHOWN ARE MAXIMUM
 - e. FULL THREAD DEPTHS SHOWN ARE MINIMUM
 - f. CHAMFER ALL TAPED HOLES TO (NOMINAL DIA + 1/16) x 90°
- 3) FINISH:

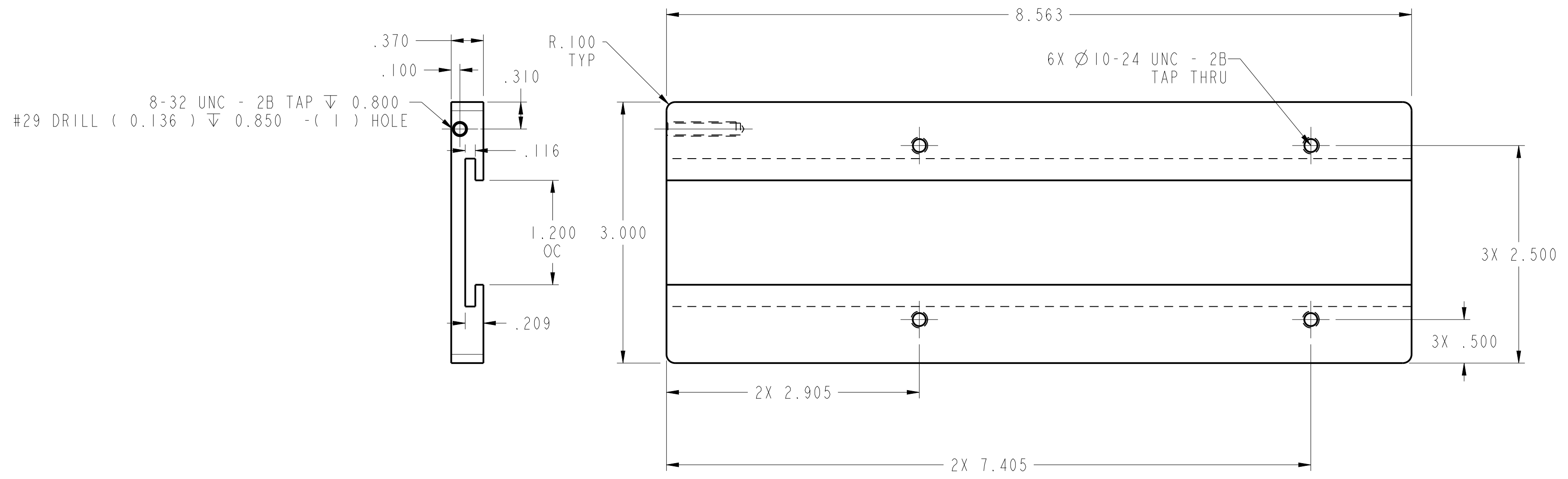
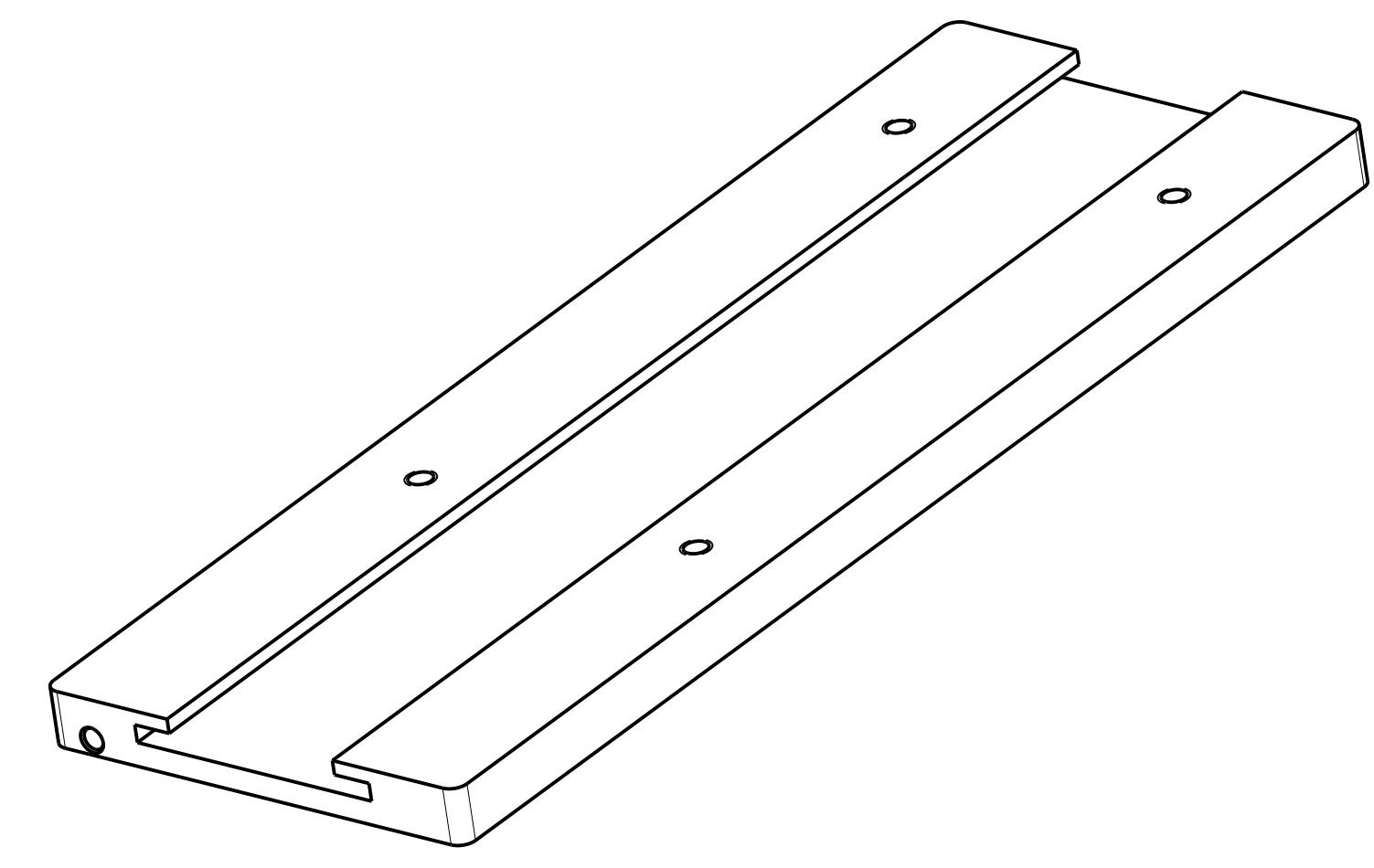

-1	CAGE	-1	CRADLE	6061-T6 ALUMINUM	1
-1	PART NUMBER		DESCRIPTION	MATERIAL/SPECIFICATION/NOTES	ITEM
BILL OF MATERIAL/PARTS LIST					
DEFAULT TOLERANCES			APPROVAL SIGNATURES		
ONE PLACE (X.X) = ± 0.1	DESIGNED BY: T. HABY		<p>SOUTHWEST RESEARCH INSTITUTE OFFICE of AUTOMOTIVE ENGINEERING 6220 CULEBRA ROAD SAN ANTONIO, TEXAS 78238</p> <p>ANALYZER SLIDE CRADLE</p>		
TWO PLACES (X.XX) = ± 0.01	CHECKED BY: P. LANG				
THREE PLACES (X.XXX) = ± 0.005	DESIGNED BY: LANG/CASTANO				
FOUR PLACES (X.XXXX) = ± 0.0005	DESIGNED BY: LANG/CASTANO				
ANGLES = ± 0.5 DEGREE	DATE COMPLETION DATE:				
SURFACE FINISHES <= 125 MICROINCH RA	FILE MODEL: SLIDE-CRADLE		SCALE 1/1 UNIT WEIGHT = LBS SHEET 1 OF 1		
THIRD ANGLE PROJECTION			EXCEPT AS MAY OTHERWISE BE PROVIDED BY CONTRACT, THESE DIMENSIONS AND SPECIFICATIONS ARE THE PROPERTY OF SOUTHWEST RESEARCH INSTITUTE, ARE ISSUED IN STRICT CONFIDENCE, AND SHALL NOT BE REPRODUCED, OR COPIED, OR USED AS THE BASIS FOR MANUFACTURE OR SALE OF ANY APPARATUS SHOWN HEREON WITHOUT PERMISSION.		
		D 26401		01910-431-200-001 A	

REVISIONS				
REV	SHT	ZONE	DESCRIPTION	DATE
A			INITIAL RELEASE	01 NOV 2013

GENERAL NOTES

- 1) DO NOT SCALE THIS DRAWING
- 2) UNLESS OTHERWISE STATED:
 - a. ALL DIMENSIONING AND TOLERANCING IS IN INCHES PER ASME Y14.5-2009
 - b. BREAK ALL SHARP CORNERS AND SHARP EDGES R .010 MAXIMUM
 - c. MACHINED SURFACE FINISHES SHALL BE 125 MICROINCH OR BETTER
 - d. TAP DRILL DEPTHS SHOWN ARE MAXIMUM
 - e. FULL THREAD DEPTHS SHOWN ARE MINIMUM
 - f. CHAMFER ALL TAPED HOLES TO (NOMINAL DIA + 1/16) x 90°
- 3) FINISH:

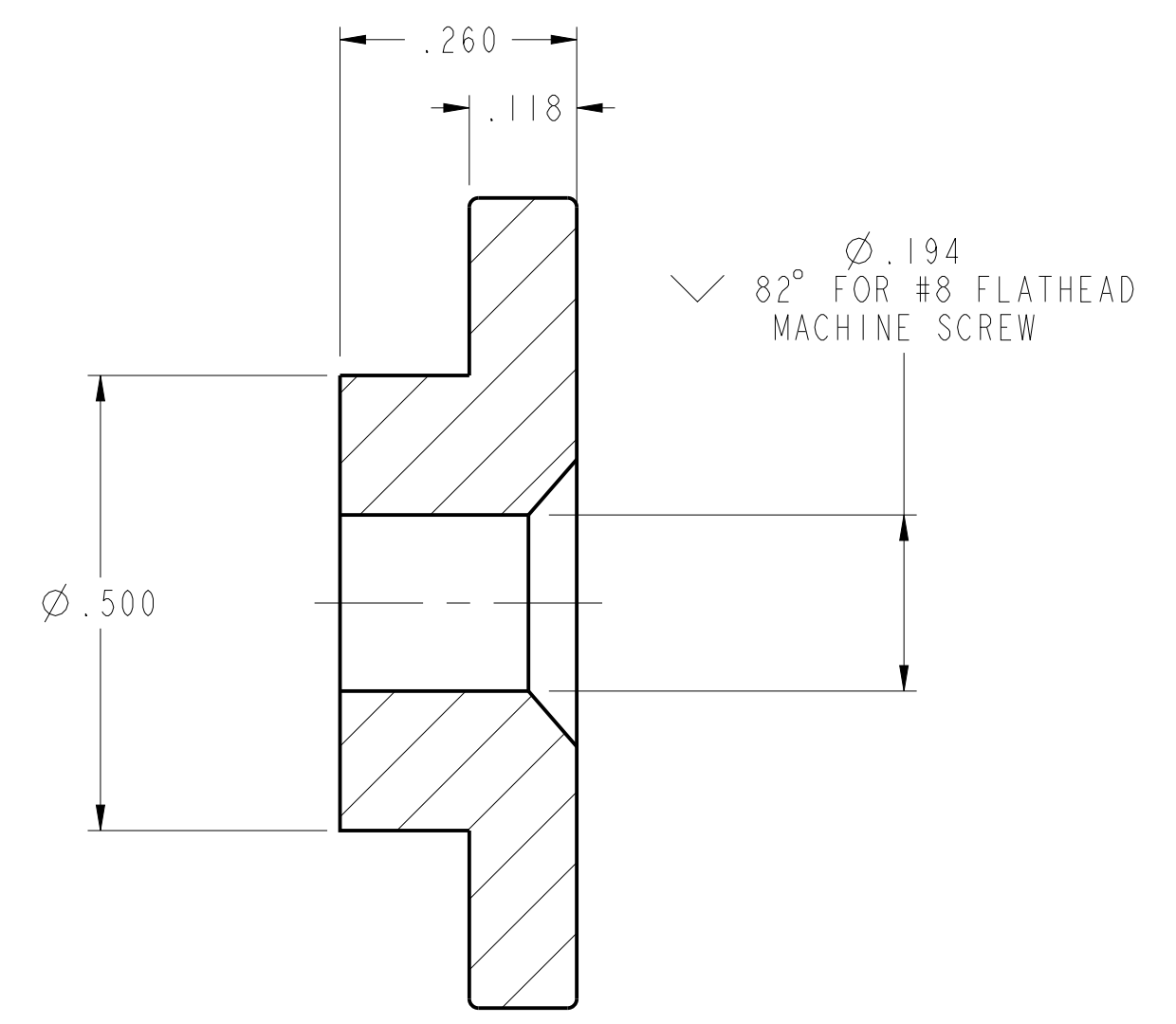
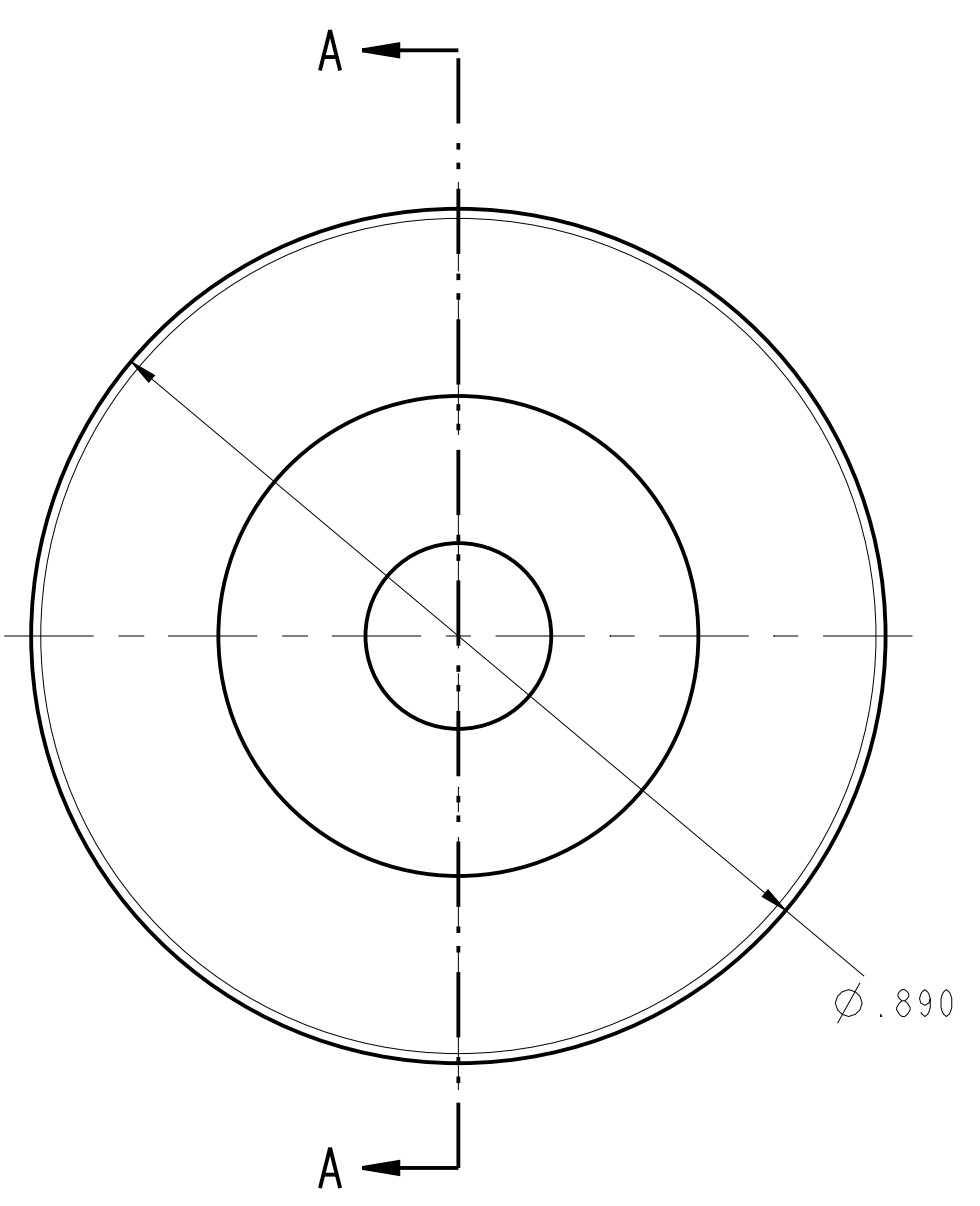

SECTION A-A

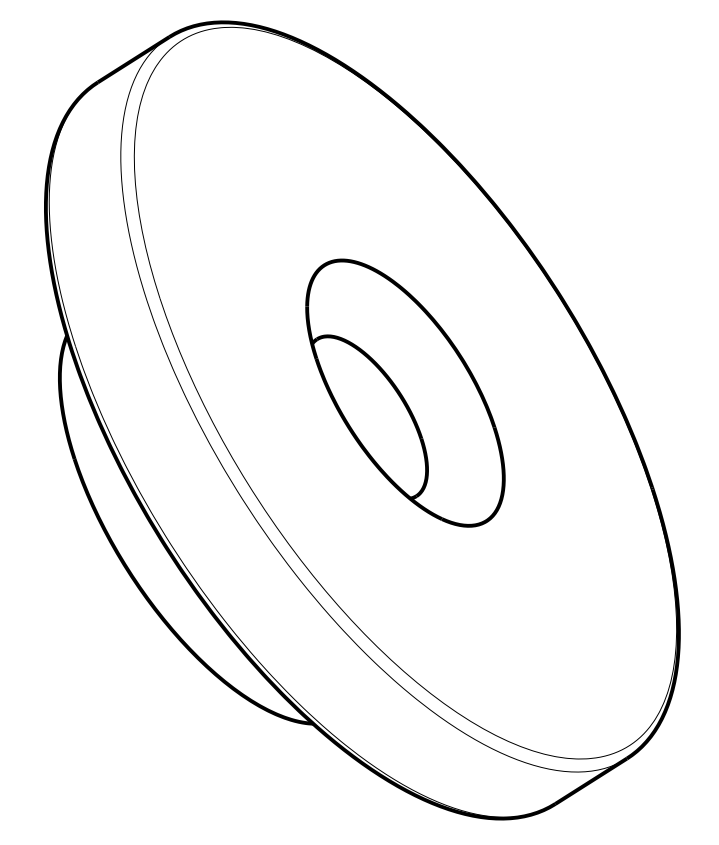

-1	CAGE	-1	SLIDE DISC	NYLON	1
-1	PART NUMBER		DESCRIPTION	MATERIAL/SPECIFICATION/NOTES	ITEM
BILL OF MATERIAL/PARTS LIST					
DEFAULT TOLERANCES			APPROVAL SIGNATURES		
ONE PLACE (X.X) = ± 0.1	DESIGNED BY: T HUBY		SOUTHWEST RESEARCH INSTITUTE OFFICE of AUTOMOTIVE ENGINEERING 6220 CULEBRA ROAD SAN ANTONIO, TEXAS 78238		
TWO PLACES (X.XX) = ± 0.01	CHECKED BY: P LANG				
THREE PLACES (X.XXX) = ± 0.005	DESIGNED BY: LANG/CASTANO				
FOUR PLACES (X.XXXX) = ± 0.0005	DESIGNED BY: LANG/CASTANO				
ANGLES = ± 0.5 DEGREE	DATE COMPLETION DATE:		CRADLE SLIDE TRACK DISC SCALE 5/1 UNIT WEIGHT = LBS SHEET 1 OF 1		
SURFACE FINISHES <= 125 MICROINCH RA	FILE MODEL: CRADLE_TRACK_DISC				
THIRD ANGLE PROJECTION			EXCEPT AS MAY OTHERWISE BE PROVIDED BY CONTRACT, THESE DRAWINGS AND SPECIFICATIONS ARE THE PROPERTY OF SOUTHWEST RESEARCH INSTITUTE, ARE ISSUED IN STRICT CONFIDENCE, AND SHALL NOT BE REPRODUCED, OR COPIED, OR USED AS THE BASIS FOR MANUFACTURE OR SALE OF ANY APPARATUS SHOW THEREON WITHOUT PERMISSION.		
			PART NUMBER: D 26401 DRAWING NUMBER: 01910-431-200-002 REV: A		

REVISIONS				
REV	SHT	ZONE	DESCRIPTION	DATE
A			INITIAL RELEASE	01 NOV 2013

GENERAL NOTES

- 1) DO NOT SCALE THIS DRAWING
- 2) UNLESS OTHERWISE STATED:
 - a. ALL DIMENSIONING AND TOLERANCING IS IN INCHES PER ASME Y14.5-2009
 - b. BREAK ALL SHARP CORNERS AND SHARP EDGES R .010 MAXIMUM
 - c. MACHINED SURFACE FINISHES SHALL BE 125 MICROINCH OR BETTER
 - d. TAP DRILL DEPTHS SHOWN ARE MAXIMUM
 - e. FULL THREAD DEPTHS SHOWN ARE MINIMUM
 - f. CHAMFER ALL TAPED HOLES TO (NOMINAL DIA + 1/16) x 90°
- 3) FINISH:

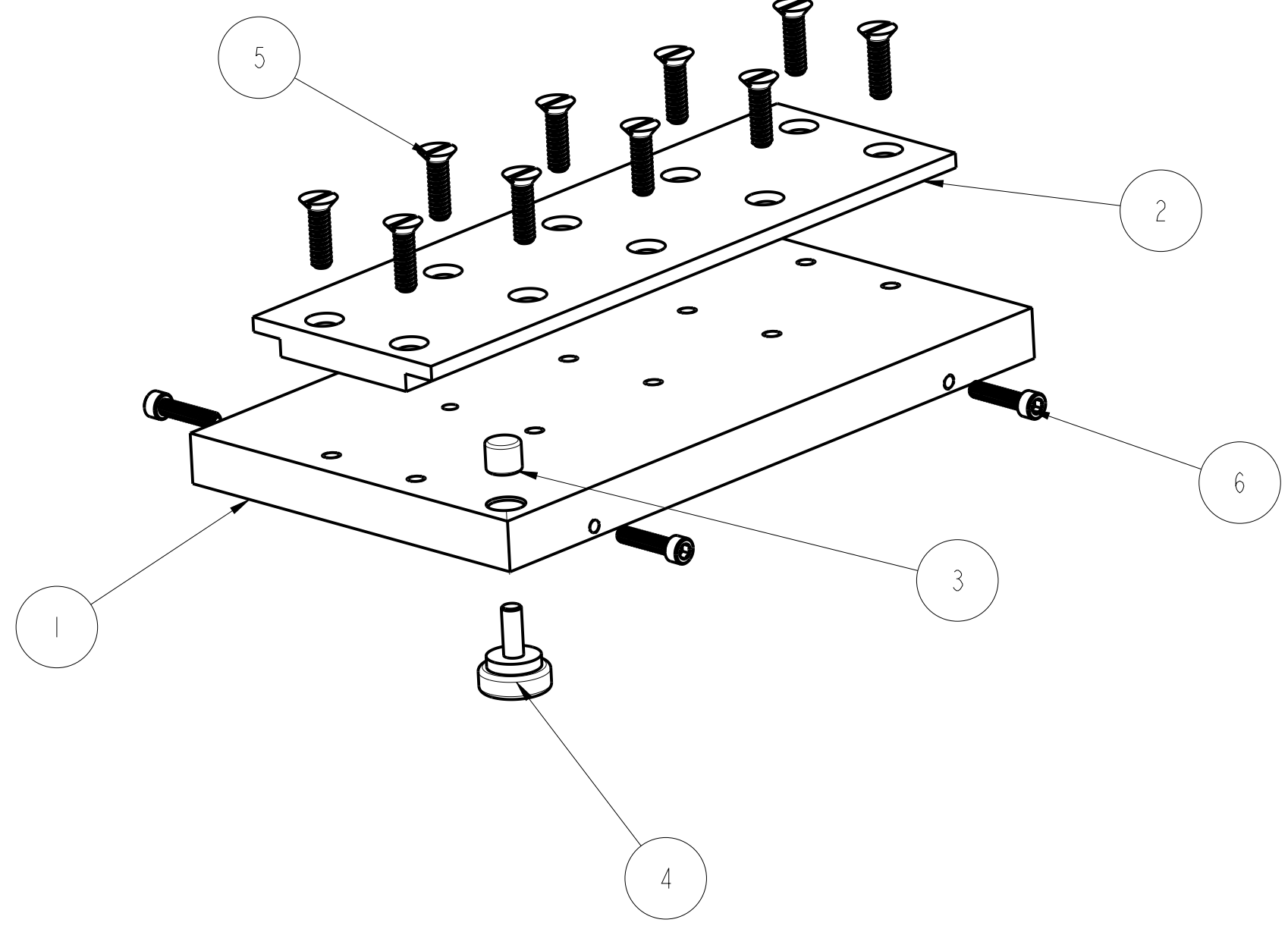
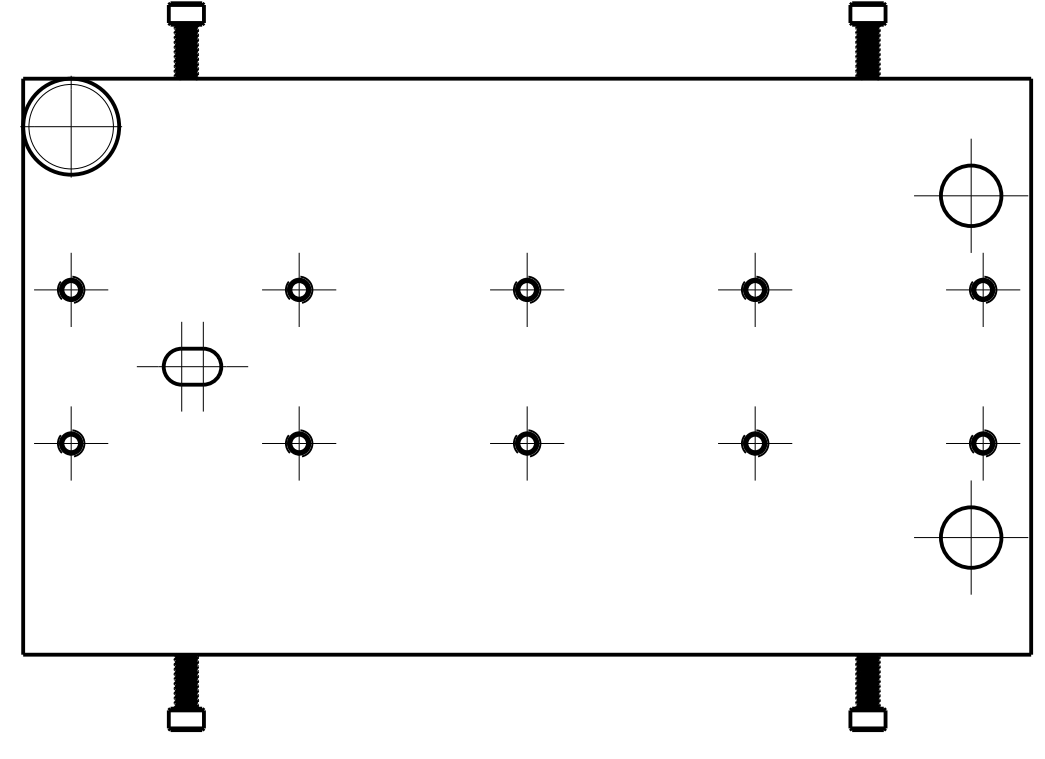
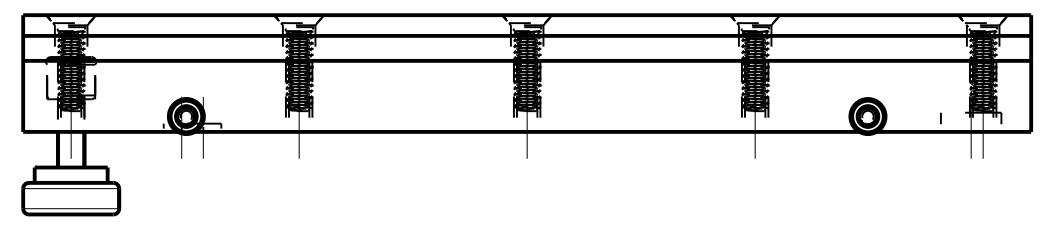
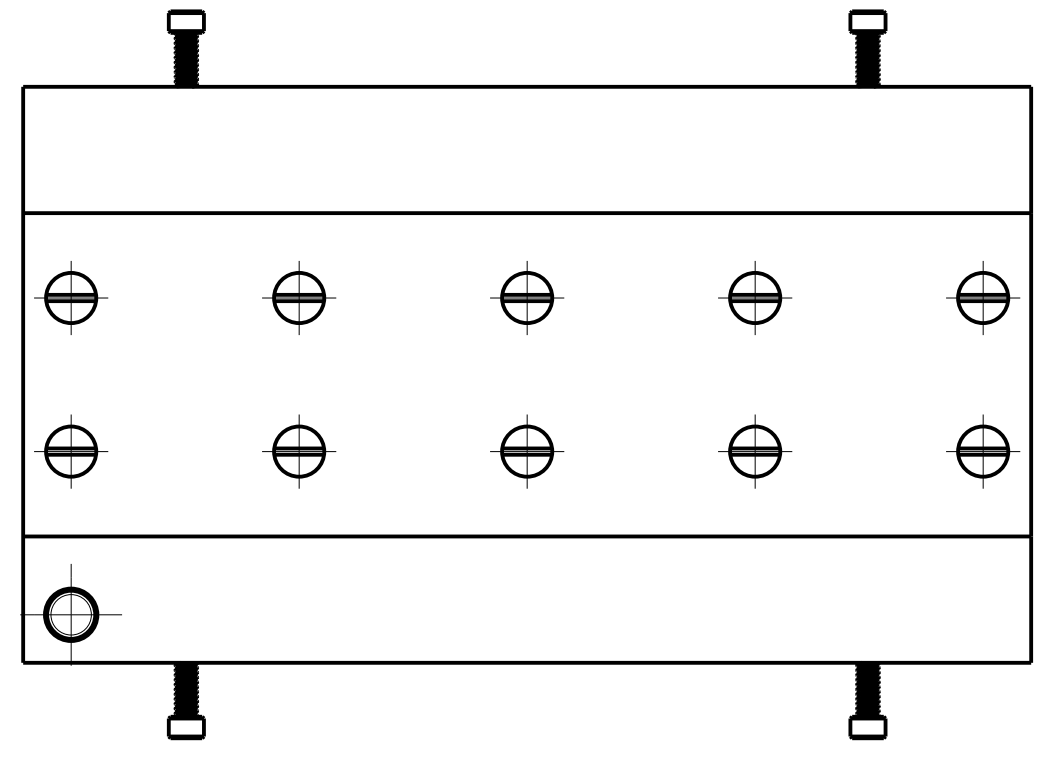

QTY	CAGE	PART NUMBER	DESCRIPTION	MATERIAL/SPECIFICATION/NOTES	ITEM
4			Ø4-40 X 1/2 SHCS		6
10			Ø6-32 X 1/2 FLAT HEAD SCREW		5
1			6-32 THREADED KNOB		4
1		01910-431-300-003	BUSHING		3
1		01910-431-300-002	SLIDE TRACK		2
1		01910-431-300-001	SLIDE MOUNT		1

DEFAULT TOLERANCES ONE PLACE (X.X) = ± 0.1 TWO PLACES (X.XX) = ± 0.01 THREE PLACES (X.XXX) = ± 0.005 FOUR PLACES (X.XXXX) = ± 0.0005 ANGLES = ± 0.5 DEGREE SURFACE FINISHES <= 125 MICROINCH RA		APPROVAL SIGNATURES DESIGNED BY: T. HABY CHECKED BY: P. LANG DRAWN BY: LANG/CASTANO DATE: LANG/CASTANO DATE COMPLETION: DATE: FILE MODEL: ANALYZER_MOUNT		SOUTHWEST RESEARCH INSTITUTE OFFICE of AUTOMOTIVE ENGINEERING 6220 CULEBRA ROAD SAN ANTONIO, TEXAS 78238 ANALYZER MOUNT	
THIRD ANGLE PROJECTION 		EXCEPT AS MAY OTHERWISE BE PROVIDED BY CONTRACT, THESE DIMENSIONS AND SPECIFICATIONS ARE THE PROPERTY OF SOUTHWEST RESEARCH INSTITUTE, ARE ISSUED IN STRICT CONFIDENCE, AND SHALL NOT BE REPRODUCED, OR COPIED, OR USED AS THE BASIS FOR MANUFACTURE OR SALE OF ANY APPARATUS SHOWN HEREON WITHOUT PERMISSION.		SCALE 1/1 UNIT WEIGHT = LBS SHEET 1 OF 1	

GENERAL NOTES

- 1) DO NOT SCALE THIS DRAWING
- 2) UNLESS OTHERWISE STATED:
 - a. ALL DIMENSIONING AND TOLERANCING IS IN INCHES PER ASME Y14.5-2009
 - b. BREAK ALL SHARP CORNERS AND SHARP EDGES R .010 MAXIMUM
 - c. MACHINED SURFACE FINISHES SHALL BE 125 MICROINCH OR BETTER
 - d. TAP DRILL DEPTHS SHOWN ARE MAXIMUM
 - e. FULL THREAD DEPTHS SHOWN ARE MINIMUM
 - f. CHAMFER ALL TAPED HOLES TO (NOMINAL DIA + 1/16) x 90°
- 3) FINISH:

REVISIONS				
REV	SHT	ZONE	DESCRIPTION	DATE
A			INITIAL RELEASE	01 NOV 2013

D

C

B

A

D

C

B

A

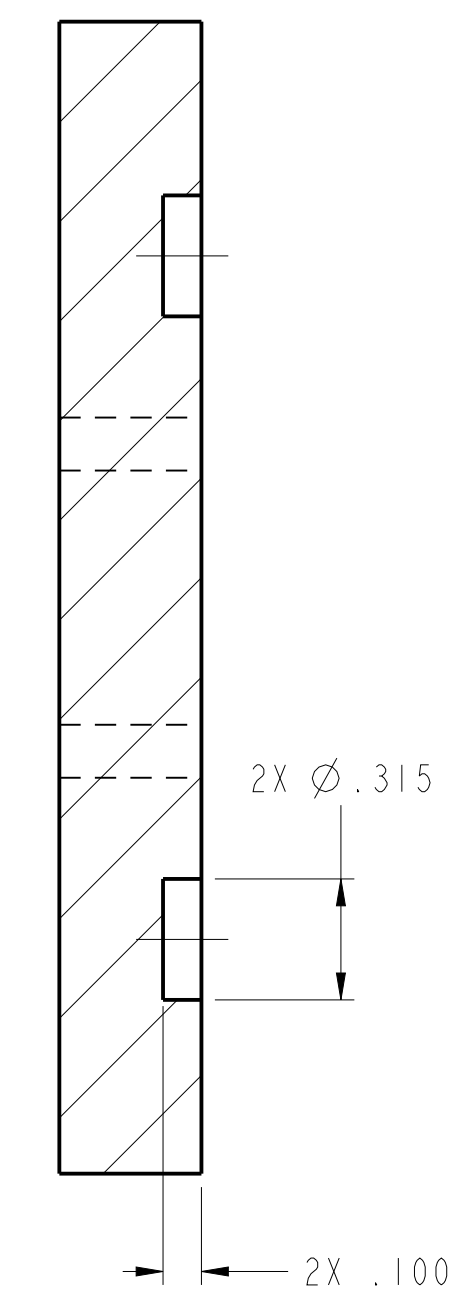

SECTION A-A

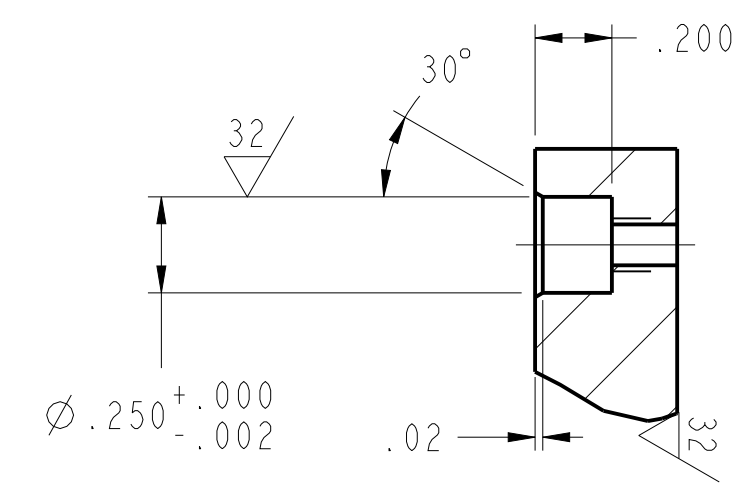

SECTION B-B

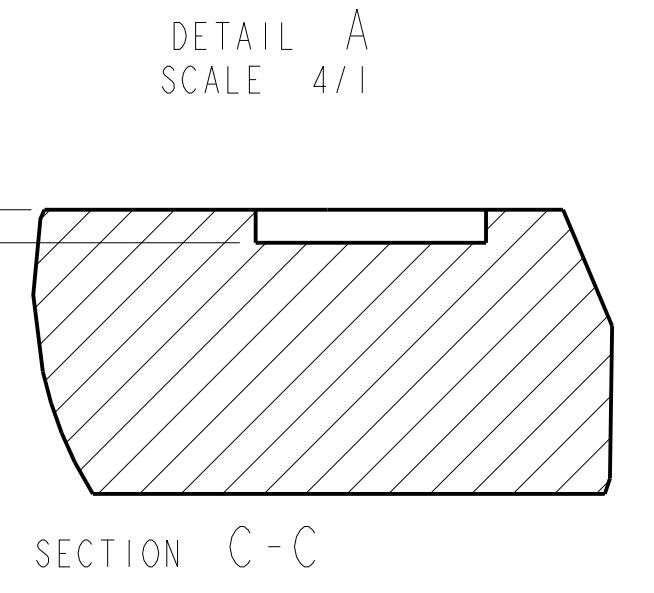
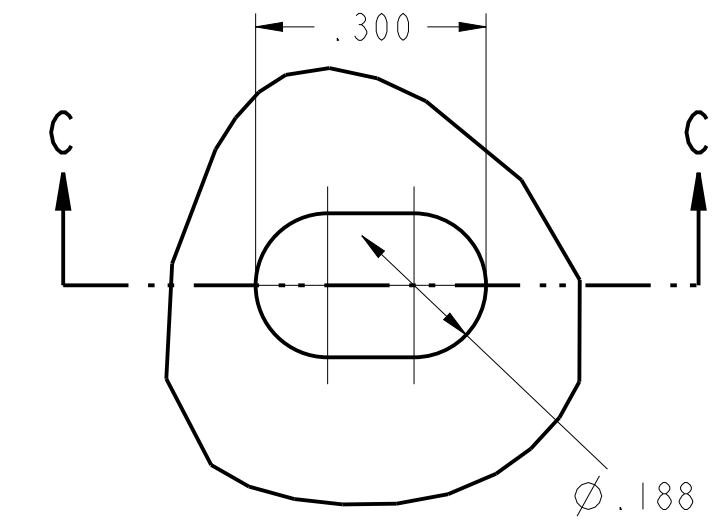
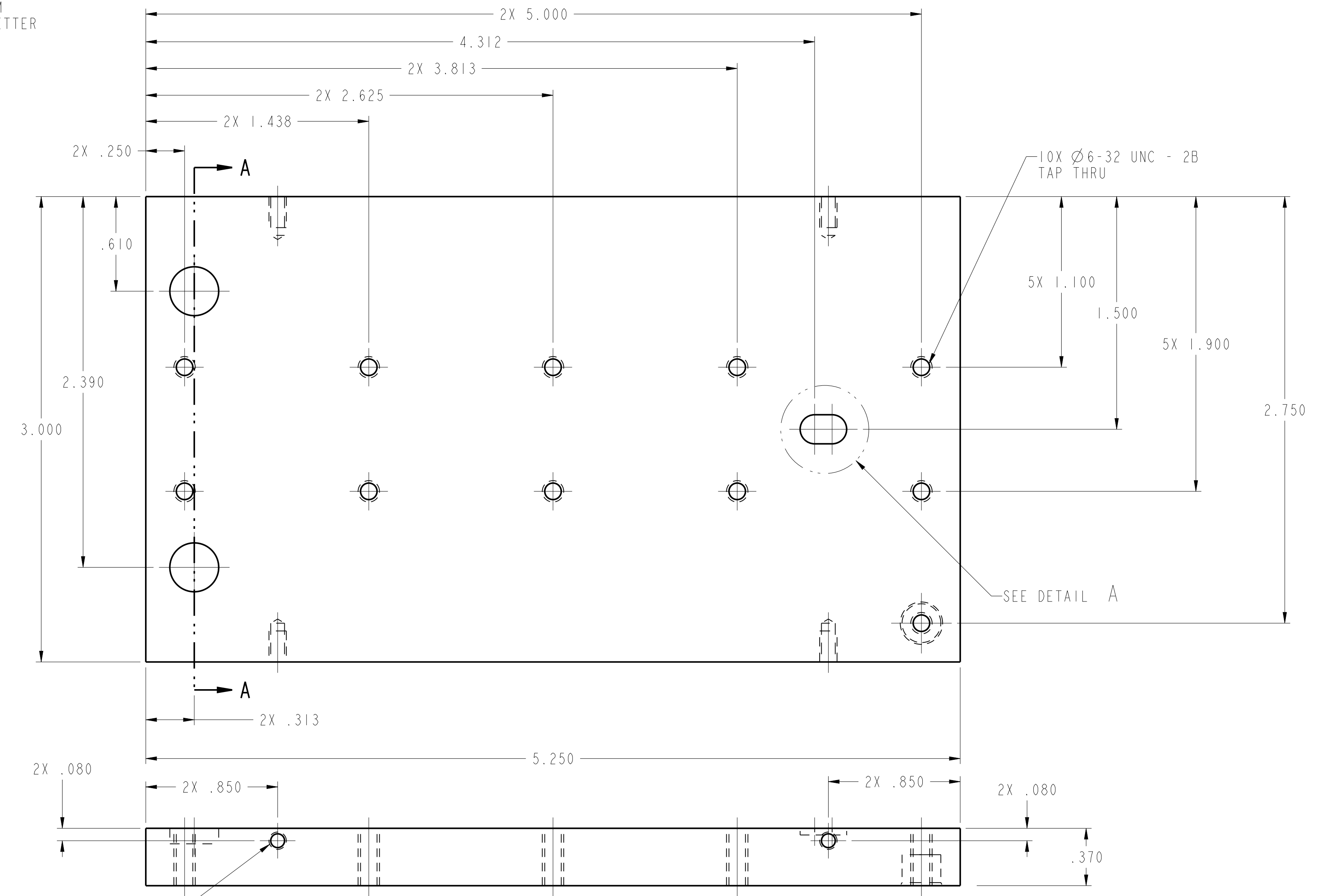

4X Ø4-40 UNC -2B
TAP DRILL .20
DRILL .25

Ø6-32 UNC - 2B
TAP THRU

-1	CAGE	-1	SLIDE MOUNT	6061-T6 ALUMINUM	1
-1	PART NUMBER		DESCRIPTION	MATERIAL/SPECIFICATION/NOTES	ITEM
BILL OF MATERIAL/PARTS LIST					
DEFAULT TOLERANCES			APPROVAL SIGNATURES		
ONE PLACE (X.X) = ± 0.1			DESIGNER: T. HABY		
TWO PLACES (X.XX) = ± 0.01			CHECKER: P. LANGE		
THREE PLACES (X.XXX) = ± 0.005			DRAWN: LANG/CASTANO		
FOUR PLACES (X.XXXX) = ± 0.0005			DATE: LANG/CASTANO		
ANGLES = ± 0.5 DEGREE			DATE COMPLETION DATE:		
SURFACE FINISHES <= 125 MICROINCH RA			FILE MODEL: ANALYZER_MOUNT_BASE		
THIRD ANGLE PROJECTION			EXCEPT AS OTHERWISE PROVIDED BY CONTRACT, THESE DIMENSIONS AND SPECIFICATIONS ARE THE PROPERTY OF SOUTHWEST RESEARCH INSTITUTE, ARE ISSUED IN STRICT CONFIDENCE, AND SHALL NOT BE REPRODUCED, OR COPIED, OR USED AS THE BASIS FOR MANUFACTURE OR SALE OF ANY APPARATUS SHOWN HEREON WITHOUT PERMISSION.		
DRAWN: D		CAGE: 26401		PART NUMBER: 01910-431-300-001	
SCALE: 2/1		UNIT WEIGHT: LBS		SHEET 1 OF 1	

SOUTHWEST RESEARCH INSTITUTE
OFFICE of AUTOMOTIVE ENGINEERING
6220 CULEBRA ROAD SAN ANTONIO, TEXAS 78238

ANALYZER SLIDE MOUNT

REVISIONS				
REV	SHT	ZONE	DESCRIPTION	DATE
A			INITIAL RELEASE	01 NOV 2013

GENERAL NOTES

- 1) DO NOT SCALE THIS DRAWING
- 2) UNLESS OTHERWISE STATED:
 - a. ALL DIMENSIONING AND TOLERANCING IS IN INCHES PER ASME Y14.5-2009
 - b. BREAK ALL SHARP CORNERS AND SHARP EDGES R .010 MAXIMUM
 - c. MACHINED SURFACE FINISHES SHALL BE 125 MICROINCH OR BETTER
 - d. TAP DRILL DEPTHS SHOWN ARE MAXIMUM
 - e. FULL THREAD DEPTHS SHOWN ARE MINIMUM
 - f. CHAMFER ALL TAPED HOLES TO (NOMINAL DIA + 1/16) x 90°
- 3) FINISH:

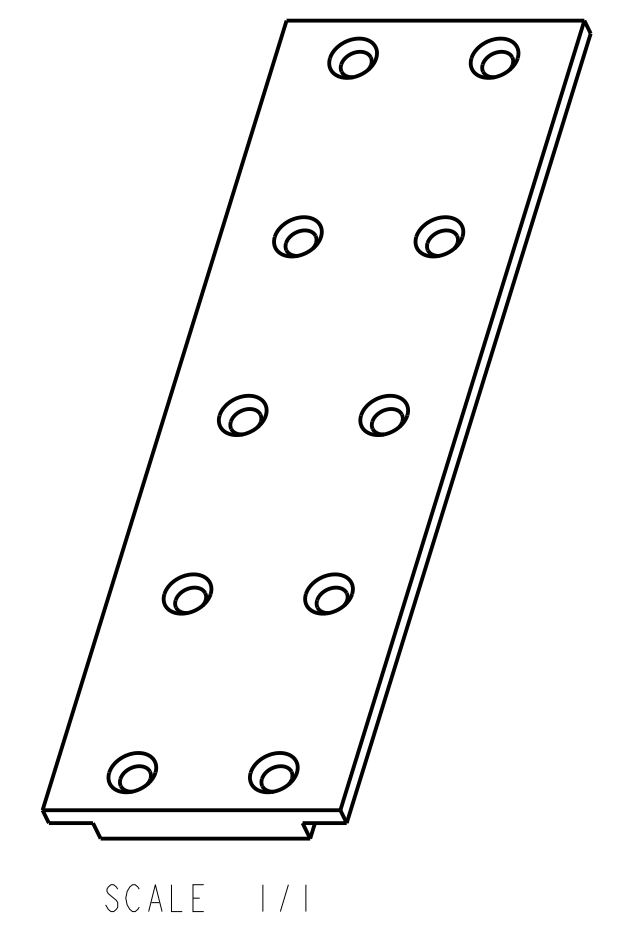
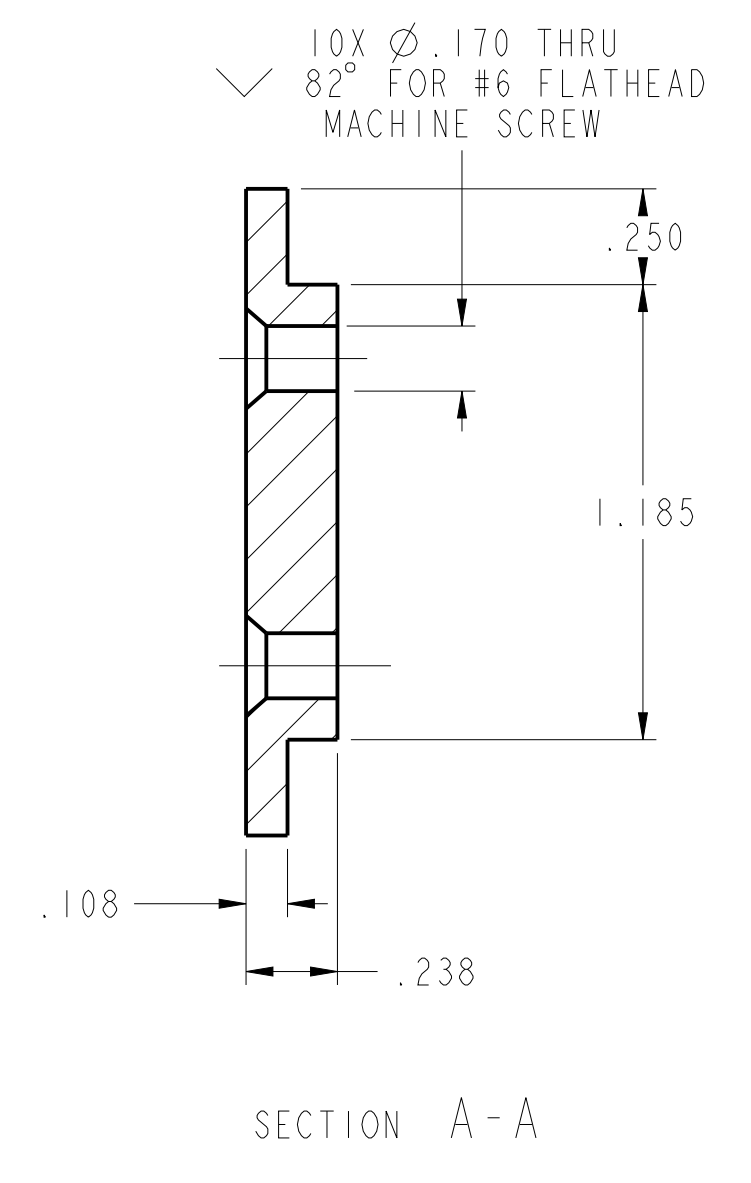
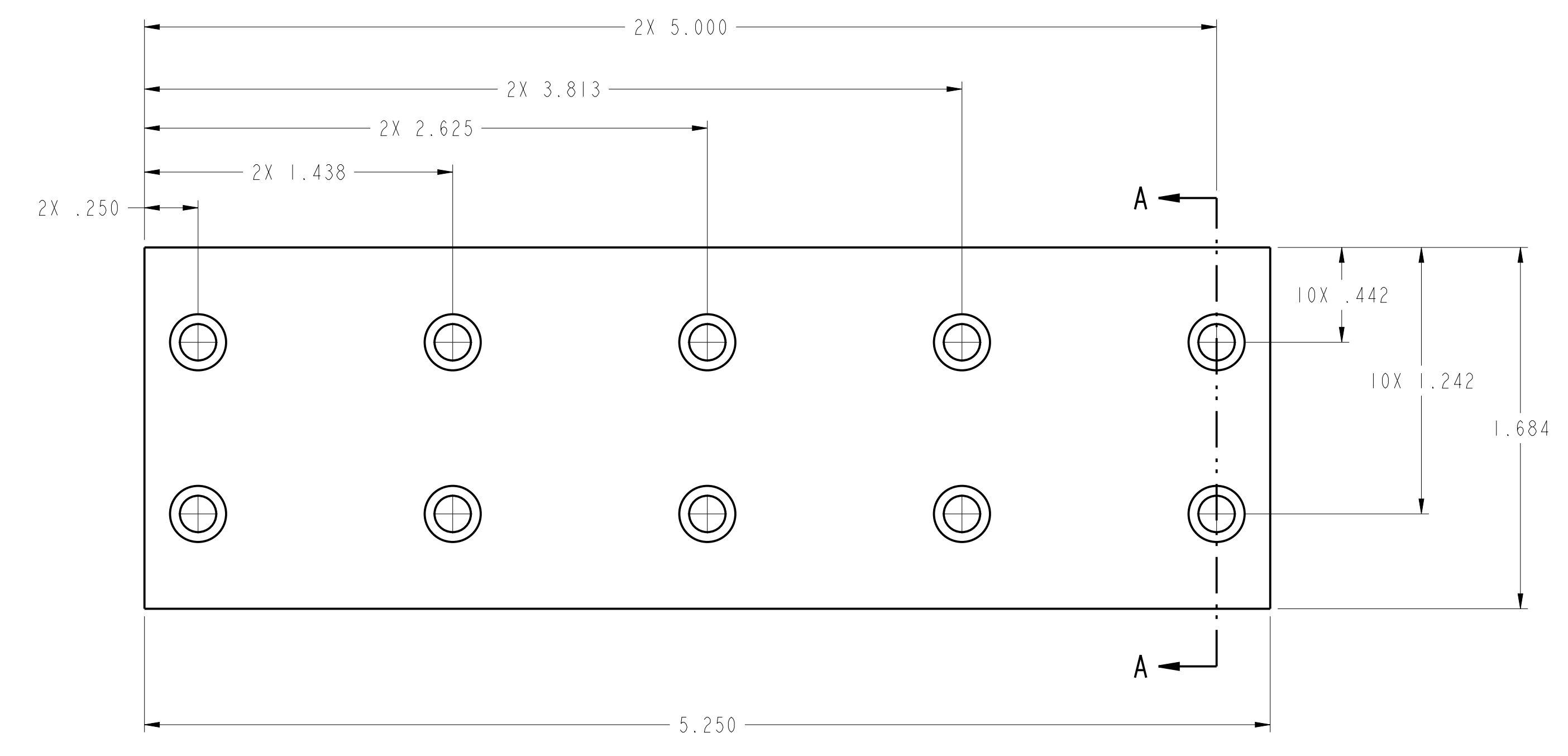

-1	CAGE	-1	SLIDE TRACK	NYLON	1
-1	PART NUMBER		DESCRIPTION	MATERIAL/SPECIFICATION/NOTES	ITEM
BILL OF MATERIAL/PARTS LIST					
DEFAULT TOLERANCES			APPROVAL SIGNATURES		
ONE PLACE (X.X) = ± 0.1	DESIGNED BY: T HADY				
TWO PLACES (X.XX) = ± 0.01	CHECKED BY: P LANG				
THREE PLACES (X.XXX) = ± 0.005	DRAWN BY: LANG/CASTANO				
FOUR PLACES (X.XXXX) = ± 0.0005	PROJ. BY: LANG/CASTANO				
ANGLES = ± 0.5 DEGREE	DATE COMPLETION DATE:				
SURFACE FINISHES <= 125 MICROINCH RA	FILE MODEL: ANALYZER_MOUNT_SLIDE				
THIRD ANGLE PROJECTION			EXCEPT AS MAY OTHERWISE BE PROVIDED BY CONTRACT, THESE DIMENSIONS AND SPECIFICATIONS ARE THE PROPERTY OF SOUTHWEST RESEARCH INSTITUTE, ARE ISSUED IN STRICT CONFIDENCE, AND SHALL NOT BE REPRODUCED, OR COPIED, OR USED AS THE BASIS FOR MANUFACTURE OR SALE OF ANY APPARATUS SHOW HEREON WITHOUT PERMISSION.		
		D 26401		01910-431-300-002 A	
		SCALE 2/1		UNIT WEIGHT = LBS	
				SHEET 1 OF 1	

SOUTHWEST RESEARCH INSTITUTE
 OFFICE of AUTOMOTIVE ENGINEERING
 6220 CULEBRA ROAD SAN ANTONIO, TEXAS 78238

SLIDE TRACK

GENERAL NOTES

- 1) DO NOT SCALE THIS DRAWING
- 2) UNLESS OTHERWISE STATED:
 - a. ALL DIMENSIONING AND TOLERANCING IS IN INCHES PER ASME Y14.5-2009
 - b. BREAK ALL SHARP CORNERS AND SHARP EDGES R .010 MAXIMUM
 - c. MACHINED SURFACE FINISHES SHALL BE 125 MICROINCH OR BETTER
 - d. TAP DRILL DEPTHS SHOWN ARE MAXIMUM
 - e. FULL THREAD DEPTHS SHOWN ARE MINIMUM
 - f. CHAMFER ALL TAPED HOLES TO (NOMINAL DIA + 1/16) x 90°
- 3) FINISH:

REVISIONS				
REV	SHT	ZONE	DESCRIPTION	DATE
A			INITIAL RELEASE	01 NOV 2013

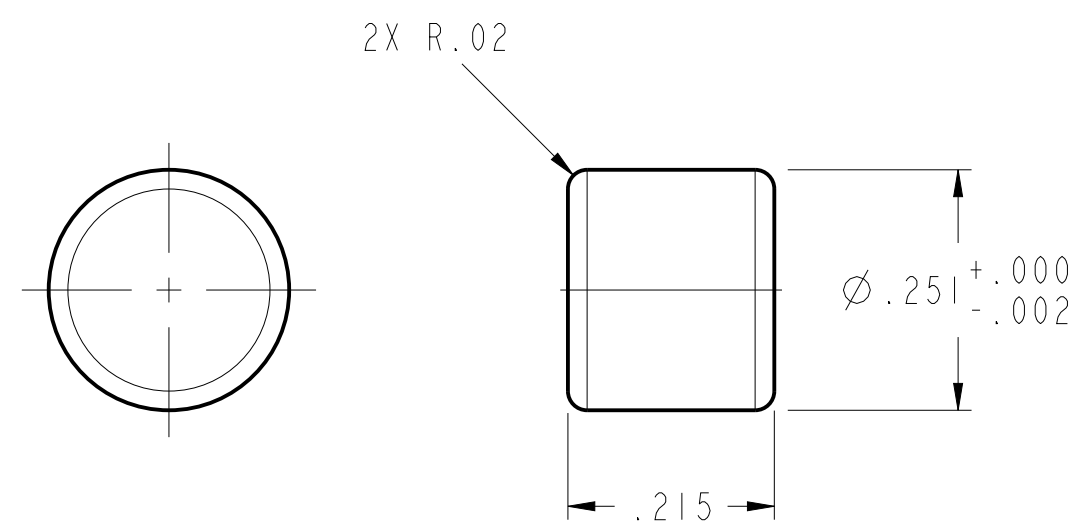
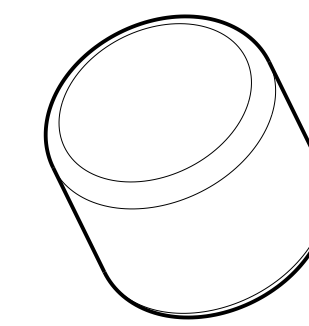

-1	CAGE	-1	BUSHING	NYLON	1
-1	CAGE	PART NUMBER	DESCRIPTION	MATERIAL/SPECIFICATION/NOTES	ITEM
BILL OF MATERIAL/PARTS LIST					
DEFAULT TOLERANCES			APPROVAL SIGNATURES		
ONE PLACE (X.X) = ± 0.1	PART HBY		SOUTHWEST RESEARCH INSTITUTE OFFICE of AUTOMOTIVE ENGINEERING 6220 CULEBRA ROAD SAN ANTONIO, TEXAS 78238		
TWO PLACES (X.XX) = ± 0.01	CWD P LANG				
THREE PLACES (X.XXX) = ± 0.005	DGG LANG/CASTANO				
FOUR PLACES (X.XXXX) = ± 0.0005	PRL LANG/CASTANO				
ANGLES = ± 0.5 DEGREE	DATE COMPLETION DATE:				
SURFACE FINISHES <= 125 MICROINCH RA	FILE MODEL: ANALYZER_CRADLE_BRAKE		EXCEPT AS MAY OTHERWISE BE PROVIDED BY CONTRACT, THESE DRAWINGS AND SPECIFICATIONS ARE THE PROPERTY OF SOUTHWEST RESEARCH INSTITUTE, ARE ISSUED IN STRICT CONFIDENCE, AND SHALL NOT BE REPRODUCED, OR COPIED, OR USED AS THE BASIS FOR MANUFACTURE OR SALE OF ANY APPARATUS SHOWN HEREON WITHOUT PERMISSION.		
THIRD ANGLE PROJECTION					
D 26401		01910-431-300-003		A	
SCALE 5/1		UNIT WEIGHT = LBS		SHEET 1 OF 1	

D

C

B

A

D

C

B

A

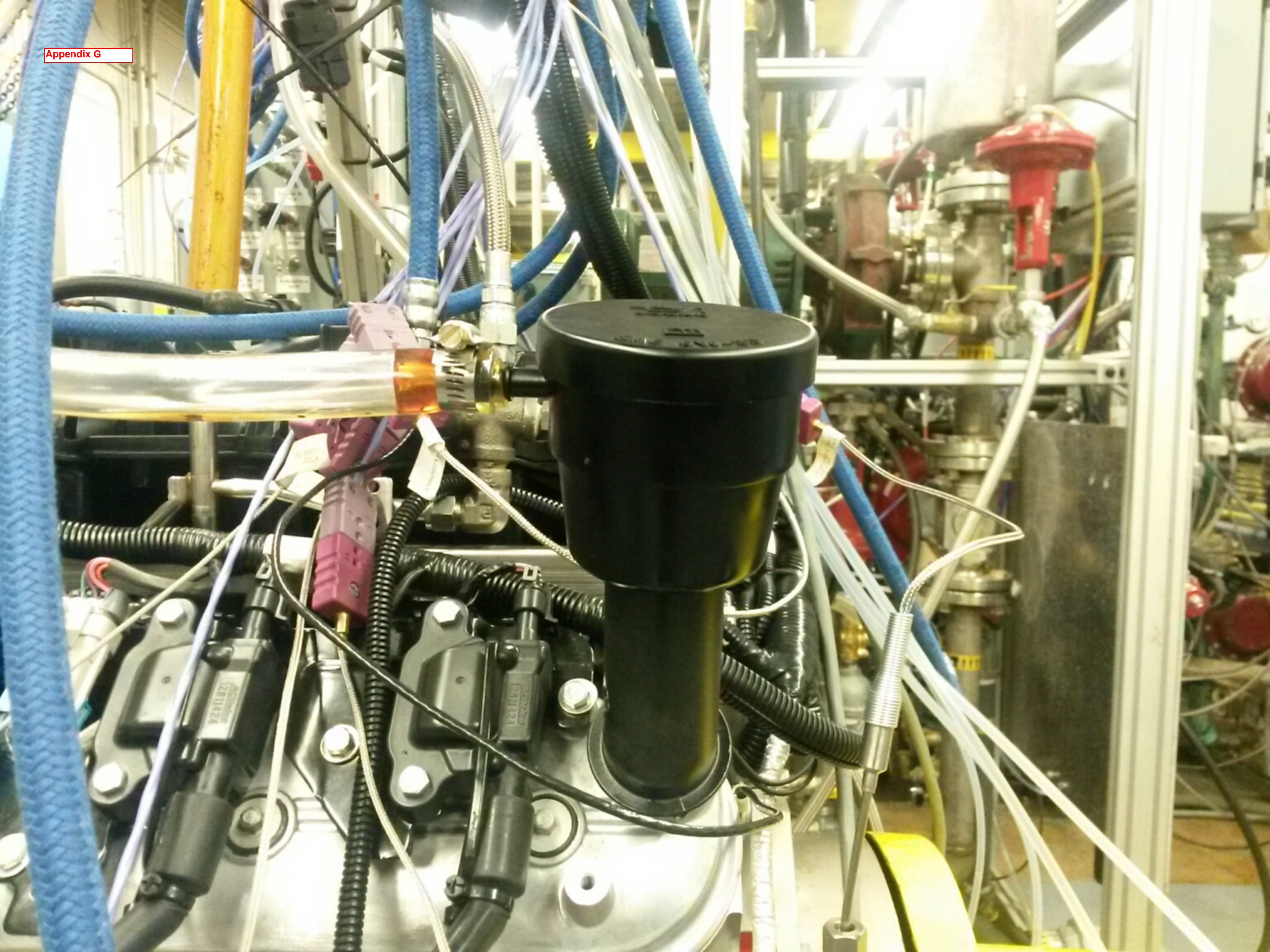

Appendix G

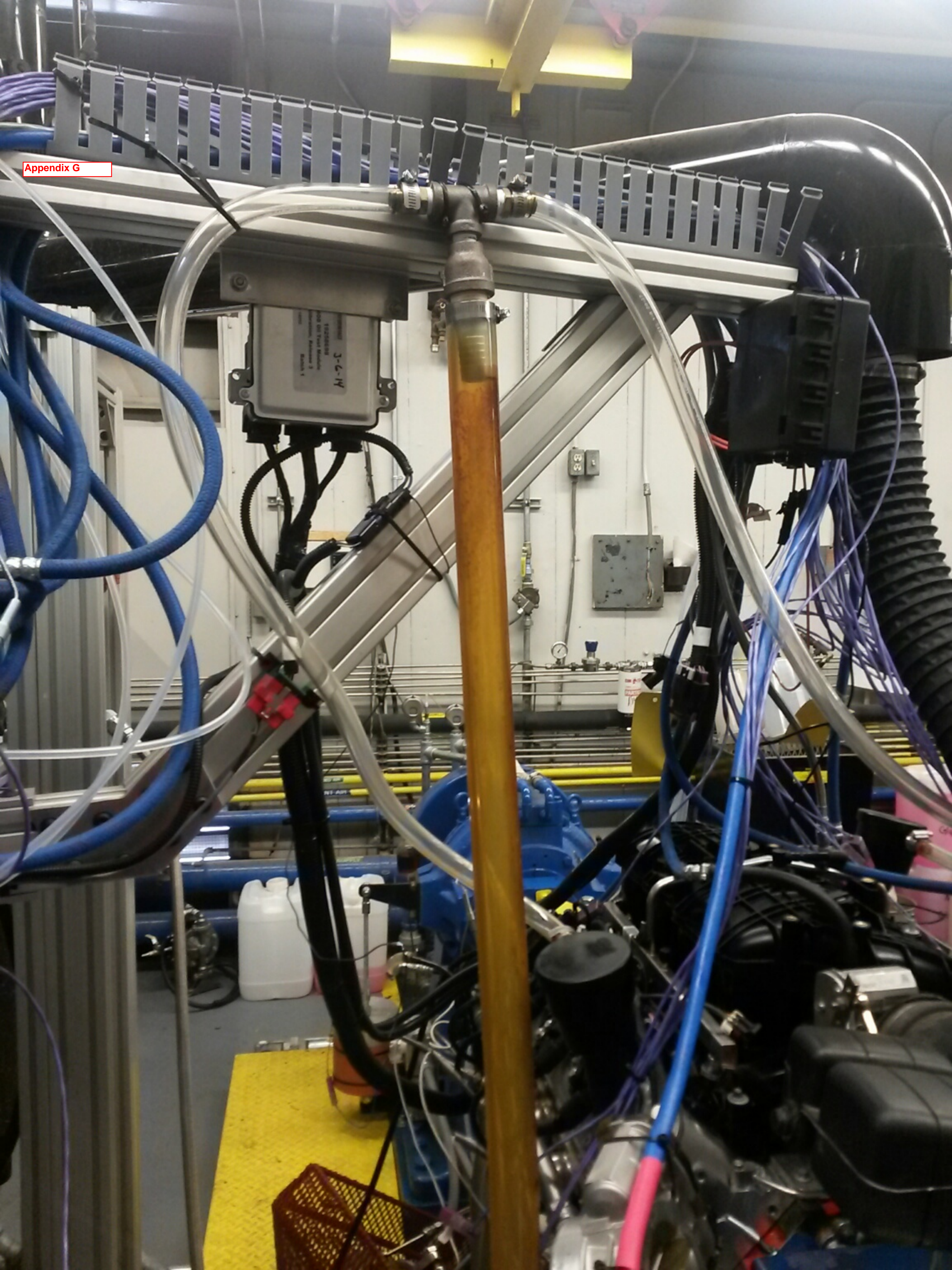

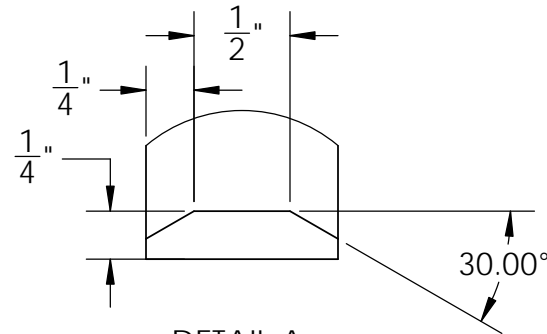
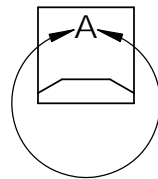
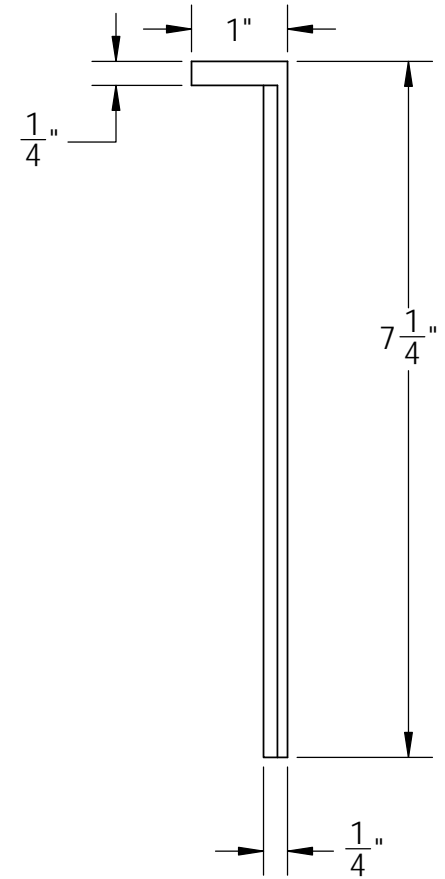
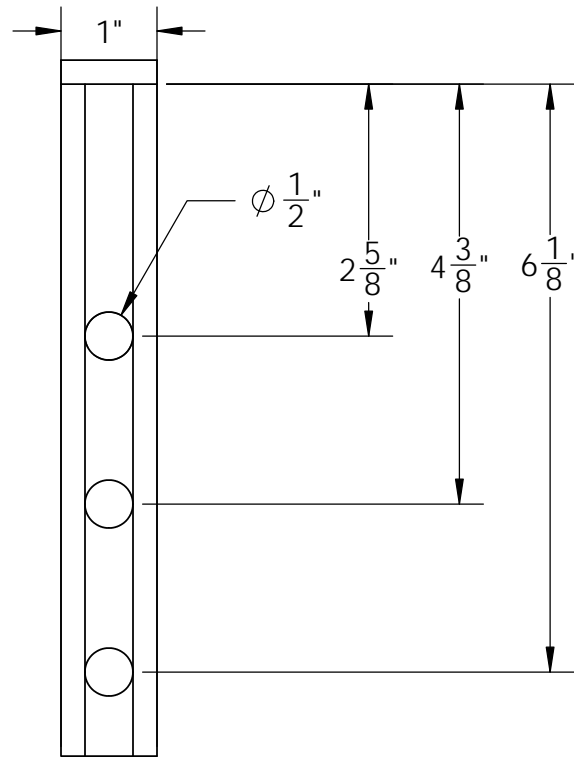
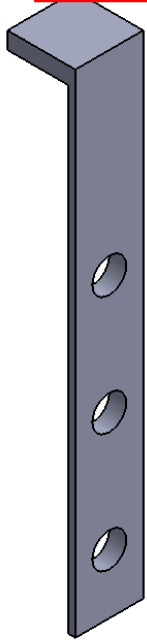

DETAIL A
SCALE 1 : 1

SOLIDWORKS Drawing Provided by
Intertek Automotive Research

		UNLESS OTHERWISE SPECIFIED:		NAME	DATE	TITLE: GMOD Bore Measurement Ladder				
		DIMENSIONS ARE IN INCHES						SIZE A	DWG. NO.	REV
		TOLERANCES: FRACTIONAL ±		DRAWN						
		ANGULAR: MACH ± BEND ±		CHECKED				SCALE: 1:2 WEIGHT: SHEET 1 OF 1		
		TWO PLACE DECIMAL ±		ENG APPR.						
		THREE PLACE DECIMAL ±		MFG APPR.						
		INTERPRET GEOMETRIC TOLERANCING PER:		Q.A.						
		MATERIAL 1/4" Aluminum Plate		COMMENTS:						
		FINISH								
	NEXT ASSY	USED ON								
	APPLICATION		DO NOT SCALE DRAWING							